

# ENGINEERING STEELS

AN EXPOSITION OF THE PROPERTIES  
OF STEEL FOR ENGINEERS AND  
USERS TO SECURE ECONOMY IN  
WORKING AND EFFICIENCY  
OF RESULT

BY

LESLIE AITCHISON, D.MET., B.Sc., M.I.A.E.

*Consulting Metallurgist to the Air Ministry, The Association  
of Drop Forgers and Stampers, etc., etc*

NEW YORK  
D. VAN NOSTRAND COMPANY  
8 WARREN STREET

667-1  
A-21

TO THE  
MEMORY OF  
MY FATHER

## PREFACE

THE developments which have taken place in engineering during the past two decades have resulted in the request, by the engineer, for materials, and particularly steels, capable of performing higher duties than the older-fashioned mild steels and wrought irons. The requirements of the automobile and aircraft industries in particular have created a demand for steels possessing distinctly high orders of mechanical properties. The metallurgists have in general supplied this demand. The mere fact that the designs of the engineer have called for a steel capable of withstanding high stresses has made it imperative for the engineer to ascertain, before use, that the steels do really possess the expected properties. This has led to extensive inspection and the compilation of many and varied specifications.

The earlier specifications merely aimed at securing stipulated mechanical test results. The advance of knowledge by both the engineer and the metallurgist has made it clear, however, that chemical composition, heat treatment, macrostructure, and microstructure have all an important bearing upon the suitability or otherwise of any material to perform the duties expected of it. Specifications have developed, therefore, and extended notably. Since a good specification can only be prepared by consent, and by contributions of knowledge from

both the maker and the user, it has been necessary for the engineer and the metallurgist to meet upon more or less common ground. This has made it necessary for the engineer to acquire a certain knowledge of steels, other than that which he usually possesses of metals as structural materials.

The object of this book is to provide the information which it is considered that the engineer should possess in order to enable him to understand the steel which he is using. The preparation of specifications for materials is not the only way in which such knowledge may be useful. The correct allocation of the possible materials to the different portions of his structure or machinery is of vital importance to any engineer. The accurate diagnosis of the causes of failure of any portion of his products is perhaps of even greater importance. For all these purposes some knowledge of steel is essential. *Savoir pour prévoir, prévoir pour pouvoir.*

In this book those matters which are of interest only to the metallurgist have been eschewed. Every subject has been viewed, as nearly as can be, from the angle of the user of the material. It is considered that the questions which are answered are those which the inquiring engineer is constantly asking. Doubtless this knowledge will be of value also to the metallurgist, particularly when he has to meet the engineer on some common ground.

Many acknowledgments must be made regarding sources of help and criticism. To Commander Wilfred Briggs, R.N., and Professor C. F. Jenkin I am very largely indebted for what I know of the point of view of the engineer. To Professor Jenkin I owe not merely "a point of view," but very many and intensely helpful conversations upon the essential properties of engineering materials. Upon

the "Report of the Materials Section of the Technical Department of the Air Ministry," compiled by Professor Jenkin (of which the section on Steel was built up mainly from reports presented by me), I have drawn frequently. It has not always been possible to give detailed references in the text to that Report, and it is hoped that this general acknowledgment will be regarded as sufficient. My sincerest thanks must also be tendered to my friend, Mr. Harry Brearley, for much information and advice, and for his kindness in allowing me to use many of his photographs of ingot sections, etc., as illustrations in this book. For other illustrations I am indebted to my friends, Mr. W. H. Dyson and Capt. L. W. Johnson, M.Met., M.C. For the pictures of various testing appliances I offer my best thanks to Dr. T. E. Stanton, Messrs. The Cambridge & Paul Instrument Company, Messrs. Brown Bayley's Steel Works, Mr. S. C. S. Hickson (Firth-Derihon Stampings), and Messrs. A. Lee & Sons. To Professor Andrew Robertson, D.Sc., and Dr. B. P. Haigh I owe the detailed notes and sketches which have enabled me to describe the appliances connected with their names.

L. A.

NEW ELDON CHAMBERS,  
CHERRY STREET, BIRMINGHAM.  
1920.

# CONTENTS

CHAP.	PAGE
FOREWORD, by Professor W. C. Unwin, LL.D., F.R.S.	xxix
I. STEEL MELTING PROCESSES .. .. .	1
II. THE CASTING AND WORKING OF STEEL .. .. .	16
III. THE HEAT TREATMENT OF STEEL .. .. .	37
IV. MECHANICAL TESTING OF STEEL .. .. .	88
V. PLAIN CARBON STEELS .. .. .	139
VI. ALLOY STEELS .. .. .	162
VII. CASE-HARDENING STEELS .. .. .	210
VIII. COLD WORKED STEELS .. .. .	264
IX. TOOL STEELS .. .. .	281

## APPENDICES

A. THE INFLUENCE OF SHARP CORNERS AND SCRATCHES ..	293
B. YOUNG'S MODULUS OF ELASTICITY .. .. .	297
C. THE PROPERTIES OF STEELS AT HIGH TEMPERATURES ..	299
D. PROFESSOR ROBERTSON'S AXIAL LOADING SHACKLES ..	302
E. AVERY "IZOD" IMPACT TESTING MACHINE .. .. .	304
F. CHARPY PENDULUM IMPACT TESTING MACHINE .. .. .	305
G. STANTON REPEATED-BLOW IMPACT TESTING MACHINE ..	308
H. HAIGH ALTERNATING-STRESS TESTING MACHINE .. ..	312
I. BRINELL BALL TEST MACHINE .. .. .	317
J. DERIHON "HARDNESS TESTING" MACHINE .. .. .	319
K. JOHNSON BALL-HARDNESS TESTING MACHINE .. .. .	321
L. LEE REVERSE TESTING MACHINE .. .. .	323
M. THE ATCHERLEY BEND TESTING MACHINE .. .. .	324

## APPENDIX

PAGE

N. BIBLIOGRAPHY OF ORIGINAL PAPERS ON THE HARDNESS OF METALS .. .. .	326
1. RESISTANCE TO ABRASION .. .. .	326
2. RESISTANCE TO INDENTATION .. .. .	327
3. SCLEROSCOPIIC .. .. .	328
4. ELECTRO-MAGNETIC .. .. .	329
INDEX .. .. .	333
PLATES .. .. .	349-396



## TABLES

NO.	PAGE
1. THE MECHANICAL PROPERTIES OF STEEL CUT FROM AN INGOT IN THREE DIFFERENT DIRECTIONS AT RIGHT ANGLES .. .. .	29
2. THE MECHANICAL PROPERTIES OF SPECIMENS OF STEELS CUT PARALLEL AND TRANSVERSE TO THE DIRECTION OF DRAWING OUT DURING FORGING.. .. .	30
3. THE EFFECT OF DIFFERENT METHODS OF COOLING UPON THE MECHANICAL PROPERTIES OF PLAIN CARBON STEELS .. .. .	55
4. THE EFFECT OF NORMALISING AND ANNEALING UPON THE MECHANICAL PROPERTIES OF DIFFERENT CARBON STEELS WITH VERY LOW MANGANESE .. .. .	68
5. MASS EFFECT OF HARDENING SHOWN BY THE MECHANICAL PROPERTIES OF BARS OF DIFFERENT SIZE HARDENED IN THE SAME WAY .. .. .	72
6. EXHIBITION OF MASS EFFECT BY BRINELL HARDNESS DETERMINATIONS UPON TWO DIFFERENT STEELS, EACH TREATED IN TWO DIFFERENT SIZES .. .. .	72
7. THE CHANGES OF SPECIFIC GRAVITY PRODUCED BY TEMPERING HARDENED STEEL .. .. .	81
8. THE VARIATION IN TOUGHNESS IN STEELS OF THE SAME MAXIMUM STRESS HEAT TREATED IN DIFFERENT WAYS	87
9. BRINELL HARDNESS NUMBER AND MAXIMUM STRESS EQUIVALENTS .. .. .	92
10. NOTCHED BAR VALUES ON STEELS BEARING DIFFERENT NOTCHES .. .. .	96
11. THE LOW "ELASTIC LIMIT" OF HARDENED ALLOY STEEL	109
12. THE EFFECT OF TEMPERING UPON THE "ELASTIC LIMIT" OF HARDENED ALLOY STEEL .. .. .	111
13. THE EFFECT OF DIRECTION OF FIBRE UPON DUCTILITY OF STEEL .. .. .	122

NO.	PAGE
14. SHOWING THE EFFECT, UPON THE ELASTIC LIMIT OF QUENCHED STEEL, OF THE APPLICATION OF VARYING NUMBERS OF ALTERNATIONS OF STRESS .. ..	134
15. SHOWING THE FATIGUE RANGE OF DIFFERENT STEELS AND THE RATIO BETWEEN IT AND THE OTHER MECHANICAL PROPERTIES OF THE STEEL .. .. .	137
16. THE EFFECT OF CARBON CONTENTS UPON THE MECHANICAL PROPERTIES OF PLAIN CARBON STEELS .. .. .	140
17. COMPLETE CHEMICAL COMPOSITION OF STEELS QUOTED IN TABLE 16. . . . .	141
18. SHOWING TYPICAL CHEMICAL COMPOSITIONS OF VARIOUS COMMERCIAL PLAIN CARBON STEELS .. .. .	142
19. THE EFFECT OF HIGH AND LOW MANGANESE CONTENTS UPON THE MECHANICAL PROPERTIES OF PLAIN CARBON STEELS IN THE NORMALISED CONDITION. . . . .	143
20. EFFECT OF HIGH AND LOW MANGANESE CONTENTS UPON THE MECHANICAL PROPERTIES OF HEAT TREATED PLAIN CARBON STEELS .. .. .	144
21. SHOWING THE EFFECT OF MASS UPON CARBON STEELS CONTAINING DIFFERENT PROPORTIONS OF MANGANESE	145
22. THE MECHANICAL PROPERTIES OF STEEL CONTAINING CARBON .. .. . 0.14 per cent. SILICON .. .. . 0.07 " MANGANESE .. .. . 0.44 " AFTER HARDENING IN WATER FROM 900° C. AND TEMPERING AT DIFFERENT TEMPERATURES .. ..	146
23. THE MECHANICAL PROPERTIES OF STEEL CONTAINING CARBON .. .. . 0.31 per cent. SILICON .. .. . 0.11 " MANGANESE .. .. . 0.58 " HARDENED FROM 850° C. IN WATER AND TEMPERED AT DIFFERENT TEMPERATURES .. .. .	147
24. THE MECHANICAL PROPERTIES OF STEEL CONTAINING CARBON .. .. . 0.45 per cent. SILICON .. .. . 0.25 " MANGANESE .. .. . 0.75 " AFTER HARDENING IN WATER FROM 870° C. AND TEMPERING AT DIFFERENT TEMPERATURES .. ..	147
25. THE EFFECT OF MASS DURING HARDENING UPON THE MECHANICAL PROPERTIES OF STEEL CONTAINING CARBON .. .. . 0.20 per cent. SILICON .. .. . 0.13 " MANGANESE .. .. . 0.95 " ALL THE BARS WERE QUENCHED FROM 760° C. AFTER REFINING AT 900° C. .. .. .	150

	NO.	PAGE
	26. THE EFFECT OF MASS UPON THE MECHANICAL PROPERTIES AFTER HEAT TREATMENT OF STEEL CONTAINING	
34	CARBON .. .. 0.45 per cent.	
	SILICON .. .. 0.25 "	
	MANGANESE .. .. 0.75 "	
	ALL THE BARS WERE QUENCHED FROM 870° C. IN WATER	150
37	27. THE MECHANICAL PROPERTIES OF TYPICAL ACID OPEN- HEARTH STEELS (NORMALISED) .. .. .	151
40	28. THE MECHANICAL PROPERTIES OF TYPICAL BASIC OPEN- HEARTH STEELS (NORMALISED) .. .. .	151
41	29. SOME TYPICAL CHEMICAL COMPOSITIONS OF ACID OPEN- HEARTH STEELS .. .. .	152
42	30. SOME TYPICAL CHEMICAL COMPOSITIONS OF BASIC OPEN- HEARTH STEELS .. .. .	152
43	31. SHOWING THE MECHANICAL PROPERTIES IN TENSION AND FATIGUE OF A STEEL CONTAINING	
	CARBON .. .. 0.36 per cent.	
44	SILICON .. .. 0.25 "	
	MANGANESE .. .. 0.66 "	
	SULPHUR .. .. 0.041 "	
45	PHOSPHORUS .. .. 0.020 "	
	AFTER NORMALISING (850° C.), AND AFTER HARDENING (850° C. IN OIL) AND TEMPERING (600° C.) .. .. .	154
	32. MECHANICAL PROPERTIES OF AIR-HARDENING STEELS AFTER COOLING IN AIR AND IN OIL .. .. .	176
46	33. SHOWING THE MECHANICAL PROPERTIES OF A STEEL CONTAINING	
	CARBON .. .. 0.31 per cent.	
	MANGANESE .. .. 0.41 "	
	NICKEL .. .. 3.9 "	
	CHROMIUM .. .. 1.37 "	
	AFTER HARDENING AND TEMPERING .. .. .	177
47	34. SHOWING THE MECHANICAL PROPERTIES OF A STEEL CONTAINING	
	CARBON .. .. 0.32 per cent.	
	MANGANESE .. .. 0.48 "	
	NICKEL .. .. 3.37 "	
	CHROMIUM .. .. 0.93 "	
	AFTER HARDENING AND TEMPERING .. .. .	180
47	35. SHOWING THE MECHANICAL PROPERTIES OF A STEEL CONTAINING	
	CARBON .. .. 0.31 per cent.	
	MANGANESE .. .. 0.45 "	
	NICKEL .. .. 3.41 "	
	CHROMIUM .. .. 0.78 "	
	AFTER HARDENING AND TEMPERING .. .. .	183

NO.	PAGE
36. SHOWING NOTCHED BAR VALUES OF A NICKEL CHROMIUM STEEL COOLED QUICKLY, AND SLOWLY, AFTER TEMPERING	184
37. SHOWING THE EFFECT OF DIFFERENT METHODS OF COOLING, FROM VARIOUS TEMPERATURES, UPON THE NOTCHED BAR VALUE OF A NICKEL CHROMIUM STEEL .. ..	186
38. SHOWING THE SUSCEPTIBILITY OF DIFFERENT NICKEL CHROMIUM STEELS TO TEMPER BRITTLINESS .. ..	187
39. SHOWING THE MECHANICAL PROPERTIES OF A STEEL CONTAINING	
CARBON .. .. . 0.29 per cent.	
MANGANESE .. .. . 0.63 ..	
NICKEL .. .. . 3.28 ..	
CHROMIUM .. .. . 0.68 ..	
AFTER HARDENING AND TEMPERING .. .. .	189
40. SHOWING THE MECHANICAL PROPERTIES OF A STEEL CONTAINING	
CARBON .. .. . 0.35 per cent.	
MANGANESE .. .. . 0.57 ..	
NICKEL .. .. . 1.57 ..	
CHROMIUM .. .. . 1.18 ..	
AFTER HARDENING AND TEMPERING .. .. .	190
41. MECHANICAL PROPERTIES AFTER HARDENING AND TEMPERING OF STEEL CONTAINING	
CARBON .. .. . 0.42 per cent.	
MANGANESE .. .. . 0.75 ..	
CHROMIUM .. .. . 1.04 ..	
VANADIUM .. .. . 0.15 ..	
ALL THE SPECIMENS WERE QUENCHED IN OIL FROM 870° C. .. .. .	193
42. SHOWING THE MECHANICAL PROPERTIES OF A STEEL CONTAINING	
CARBON .. .. . 0.35 per cent.	
MANGANESE .. .. . 0.58 ..	
NICKEL .. .. . 3.51 ..	
AFTER HARDENING AND TEMPERING .. .. .	195
43. THE MECHANICAL PROPERTIES OF DIFFERENT ALLOY STEELS AFTER COOLING IN AIR .. .. .	200
44. SHOWING THE TENSILE STRENGTH OF THE CORES OF 3-INCH BARS OF DIFFERENT NICKEL CHROMIUM STEELS COOLED IN AIR .. .. .	201
45. SHOWING THE MASS EFFECT OF HARDENING IN DIFFERENT STEELS HARDENED IN DIFFERENT WAYS .. .. .	202
46. SHOWING THE DIFFERENT HEAT TREATMENTS REQUIRED BY VARIOUS STEELS TO PRODUCE A MAXIMUM STRESS OF 75 TONS PER SQUARE INCH .. .. .	204

# TABLES

xvii

No.		PAGE
47.	SHOWING THE MECHANICAL PROPERTIES IN TENSION AND FATIGUE OF A STEEL CONTAINING	
	CARBON .. .. 0.30 per cent.	
	SILICON .. .. 0.22 "	
	MANGANESE .. .. 0.56 "	
	NICKEL .. .. 4.30 "	
	CHROMIUM .. .. 1.44 "	
	AFTER HARDENING IN AIR FROM 800° C. AND TEMPERING AT VARIOUS TEMPERATURES .. .. .	209
48.	SHOWING THE MECHANICAL PROPERTIES IN TENSION AND FATIGUE OF A STEEL CONTAINING	
	CARBON .. .. 0.32 per cent.	
	MANGANESE .. .. 0.46 "	
	NICKEL .. .. 3.48 "	
	CHROMIUM .. .. 0.78 "	
	AFTER HARDENING AND TEMPERING .. .. .	210
49.	SHOWING THE MECHANICAL PROPERTIES IN TENSION AND FATIGUE OF A STEEL CONTAINING	
	CARBON .. .. 0.44 per cent.	
	MANGANESE .. .. 0.49 "	
	CHROMIUM .. .. 0.95 "	
	VANADIUM .. .. 0.20 "	
	AFTER HARDENING AND TEMPERING .. .. .	210
50.	MECHANICAL PROPERTIES OF STAINLESS STEEL, AFTER HARDENING AND TEMPERING, CONTAINING	
	CARBON .. .. 0.40 per cent.	
	CHROMIUM .. .. 12.2 "	212
51.	CHEMICAL COMPOSITION OF TYPICAL CASE-HARDENING STEELS .. .. .	221
52.	TYPICAL MECHANICAL PROPERTIES OF THE USUAL CASE-HARDENING STEELS .. .. .	221
53.	COMPOSITION OF VARIOUS CARBURISING MIXTURES.. .. .	225
54.	SATISFACTORY CARBURISING TEMPERATURES OF CASE-HARDENING STEELS .. .. .	228
55.	COMPARATIVE TIME AT THE SAME TEMPERATURE REQUIRED BY DIFFERENT STEELS TO ABSORB THE SAME AMOUNT OF CARBON .. .. .	230
56.	SHOWING HARDENING TEMPERATURE AND SUITABLE MEDIUM FOR QUENCHING DIFFERENT CASE-HARDENING STEELS .. .. .	237
57.	SHOWING THE HARDNESS OF THE CASE AND THE STRENGTH OF THE CORE OF CASE-HARDENING STEELS COOLED IN DIFFERENT WAYS .. .. .	237

NO.	PAGE
58. REFINING AND HARDENING TEMPERATURES FOR DIFFERENT STEELS .. .. .	238
59. MASS EFFECT IN HARDENING OF CASE-HARDENING STEELS	241
60. BEAM TESTS ON CASE-HARDENED BARS, AND TENSION TESTS ON CORES OF CASE-HARDENED STEELS .. ..	249
61. THE ELASTIC LIMITS AND FATIGUE RANGES OF DIFFERENT CASE-HARDENING STEELS .. .. .	255
62. EFFECT UPON THE MECHANICAL PROPERTIES OF THE STEEL OF DIFFERENT DEGREES OF COLD WORK .. ..	266
63. EFFECT OF RE-HEATING OR BLUEING UPON THE MECHANICAL PROPERTIES OF A COLD WORKED STEEL.. ..	268
64. THE EFFECT OF BLUEING UPON THE REVERSE BEND VALUES OF A COLD WORKED STEEL .. .. .	271
65. THE EFFECT OF DIAMETER UPON THE CARBON CONTENT OF BRIGHT DRAWN STEEL BARS .. .. .	277
66. BRITISH STANDARD TOLERANCES ON BRIGHT DRAWN STEEL BARS FOR AIRCRAFT .. .. .	279
67. SHOWING THE MECHANICAL PROPERTIES IN TENSION AND FATIGUE OF A STEEL CONTAINING	
CARBON .. .. .	0.26 per cent.
SILICON .. .. .	0.05 "
MANGANESE .. .. .	0.54 "
SULPHUR .. .. .	0.031 "
PHOSPHORUS .. .. .	0.027 "
AS DRAWN AND AFTER BLUEING AT DIFFERENT TEMPERATURES .. .. .	280
68. SHOWING THE MECHANICAL PROPERTIES IN TENSION AND FATIGUE OF A STEEL CONTAINING	
CARBON .. .. .	0.25 per cent.
SILICON .. .. .	0.08 "
MANGANESE .. .. .	0.68 "
SULPHUR .. .. .	0.051 "
PHOSPHORUS .. .. .	0.043 "
AS DRAWN AND AFTER BLUEING AT DIFFERENT TEMPERATURES .. .. .	280
69. THE CARBON CONTENT OF DIFFERENT PLAIN CARBON TOOLS .. .. .	282
70. THE TEMPERATURE INDICATED BY DIFFERENT TEMPERING COLOURS .. .. .	285
71. THE MECHANICAL PROPERTIES, AFTER HARDENING AND TEMPERING, OF STEEL CONTAINING	
CARBON .. .. .	1.05 per cent.
MANGANESE .. .. .	0.23 "

NO.	PAGE
72. SHOWING THE BRINELL HARDNESS OF HIGH SPEED STEEL AFTER COOLING IN AIR FROM VARIOUS TEMPERATURES	289
73. THE EFFECT OF RE-HEATING TO VARIOUS TEMPERATURES UPON THE BRINELL HARDNESS OF HIGH SPEED STEELS	291
74. THE EFFECT OF TEMPERATURE UPON YOUNG'S MODULUS OF STEEL .. .. .	298
75. THE CHEMICAL COMPOSITION OF THE STEELS WHOSE TEST RESULTS ARE QUOTED IN TABLES 76, 77, AND 78 ..	299
76. THE MAXIMUM STRESS IN TONS PER SQUARE INCH OF DIFFERENT STEELS AT HIGH TEMPERATURES .. ..	300
77. THE BRINELL HARDNESS NUMBERS (DETERMINED BY PROFESSOR EDWARDS' IMPACT BRINELL METHOD) OF TUNGSTEN STEELS AT HIGH TEMPERATURES .. ..	300
78. THE NOTCHED BAR VALUE IN KILOGRAMMETRES OF DIFFERENT STEELS AT HIGH TEMPERATURES .. ..	301

## FIGURES IN TEXT

FIG.	PAGE
11. DIAGRAMMATIC REPRESENTATION OF THE METHOD OF FORMATION OF THE CONTRACTION CAVITIES SHOWN IN FIG. 10 .. .. .	25
14. (BREARLEY) CURVES SHOWING THE RELATIONSHIP BETWEEN THE MECHANICAL PROPERTIES OF THE STEEL AND THE ANGLE OF INCLINATION OF THE FIBRES OF THE STEEL TO THE AXIS OF THE TEST PIECE .. ..	31
15. ETCHED SECTION OF A CRANKSHAFT IN WHICH THE FIBRES OF THE STEEL FOLLOW THE CONTOUR OF THE SHAFT IN ALL PARTS .. .. .	32
23. THERMAL EQUILIBRIUM DIAGRAM OF WATER-SALT SYSTEM	42
24. THERMAL EQUILIBRIUM DIAGRAM OF LEAD-TIN SYSTEM ..	44
25. INVERSE RATE COOLING CURVES OF DIFFERENT MIXTURES OF LEAD AND TIN .. .. .	45
26. INVERSE RATE COOLING CURVES OF FOUR STEELS ..	47
27. THERMAL EQUILIBRIUM DIAGRAM (LOW TEMPERATURE PORTION) OF IRON CARBON SYSTEM .. .. .	48
31. INVERSE RATE HEATING CURVE OF STEEL CONTAINING 0.30 PER CENT. OF CARBON .. .. .	52
32. DIAGRAMMATIC REPRESENTATION OF THE INFLUENCE OF COMPOSITION UPON THE CRITICAL TEMPERATURES OF NICKEL STEELS .. .. .	56
33. CURVE SHOWING LOSS OF WEIGHT IN ACID OF SAMPLES OF HARDENED STEEL TEMPERED AT DIFFERENT TEMPERATURES .. .. .	62
39. CURVES SHOWING CHANGES OF VOLUME OCCURRING IN A STEEL AT DIFFERENT TEMPERATURES .. .. .	77
40. DIAGRAMMATIC ILLUSTRATION OF A TYPICAL FORGING ..	79
41. DIAGRAMMATIC REPRESENTATION OF IZOD IMPACT TEST	94
42. STANDARD IZOD IMPACT TEST PIECE AND NOTCH .. ..	95
43. STANDARD MESNAGER IMPACT TEST PIECE AND NOTCH ..	95



FIG.	PAGE
46. METHOD OF CARRYING OUT BEND TEST, SHOWING INSERTION OF DIE .. .. .	97
47. METHOD OF CARRYING OUT BEND TEST, SHOWING FINAL POSITION OF SPECIMEN .. .. .	97
48. METHOD OF STRESSING IN THE ARNOLD ALTERNATING STRESS TEST .. .. .	100
49. A TYPICAL CURVE OF THE OBSERVATIONS MADE IN A TRUE FATIGUE TEST .. .. .	102
50A. DIAGRAMMATIC ILLUSTRATION OF THE ARRANGEMENT OF THE WÖHLER FATIGUE TESTING MACHINE .. ..	103
50B. STANDARD TEST PIECE FOR WÖHLER FATIGUE TEST ..	103
51. AN IDEAL STRESS/STRAIN CURVE OF STEEL .. ..	108
52. A STRESS/STRAIN CURVE AS OBTAINED FROM FULLY HARDENED STEELS .. .. .	108
53. CURVES SHOWING THE EFFECT OF TEMPERING UPON THE MECHANICAL PROPERTIES OF STEEL, NOTABLY THE "ELASTIC LIMIT" .. .. .	110
54. HYPOTHETICAL CURVES SHOWING TWO EFFECTS OF TEMPERING A STEEL, NAMELY, LOWERING OF TRUE ELASTIC LIMIT AND REMOVAL OF INTERNAL STRAINS .. ..	114
55. STRESS/STRAIN CURVES OF THE SAME ALLOY STEEL: (a) FULLY HARDENED, (b) AFTER TEMPERING .. ..	115
56. STRESS/STRAIN CURVES OF TOUGH (a) AND BRITTLE (b) STEELS TESTED IN IMPACT .. .. .	126
57. DIAGRAM SHOWING THE ALTERATION OF THE FATIGUE RANGE OF A STEEL RESULTING FROM CHANGES IN THE VALUE OF THE PLUS FATIGUE STRESS .. .. .	132
58. STRESS/STRAIN CURVES OF SAMPLES OF HARDENED STEEL AFTER SUBMITTING TO DIFFERENT NUMBERS OF CYCLES OF ALTERNATING STRESS .. .. .	135
59. THE EFFECT OF TEMPERING AT DIFFERENT TEMPERATURES UPON THE MECHANICAL PROPERTIES OF PLAIN CARBON STEEL .. .. .	148
60. TIME/TEMPERATURE COOLING CURVE OF STEEL CONTAINING 0.9 PER CENT. OF CARBON .. .. .	168
61A. COOLING CURVES OF CHROMIUM STEEL COOLED FROM DIFFERENT TEMPERATURES .. .. .	170
61B. COOLING CURVES OF NICKEL CHROMIUM STEEL (AIR HARDENING) COOLED FROM DIFFERENT TEMPERATURES .. .. .	170
62. COOLING CURVE OF PURE ANTIMONY .. .. .	171
63. THE EFFECT OF TEMPERING AT DIFFERENT TEMPERATURES UPON THE MECHANICAL PROPERTIES OF 100-TON AIR-HARDENING NICKEL CHROMIUM STEEL .. .. .	178

FIG.	PAGE
64. THE EFFECT OF TEMPERING AT DIFFERENT TEMPERATURES UPON THE MECHANICAL PROPERTIES OF OIL-HARDENING NICKEL CHROMIUM STEEL .. .. .	181
65. THE EFFECT OF TEMPERING AT DIFFERENT TEMPERATURES UPON THE MECHANICAL PROPERTIES OF OIL-HARDENING NICKEL CHROMIUM STEEL .. .. .	182
66. THE EFFECT OF TEMPERING AT DIFFERENT TEMPERATURES UPON THE MECHANICAL PROPERTIES OF OIL-HARDENING NICKEL CHROMIUM STEEL CONTAINING A LOW PROPORTION OF NICKEL .. .. .	191
67. THE EFFECT OF TEMPERING AT DIFFERENT TEMPERATURES UPON THE MECHANICAL PROPERTIES OF CHROMIUM VANADIUM STEEL .. .. .	192
68. THE EFFECT OF TEMPERING AT DIFFERENT TEMPERATURES UPON THE MECHANICAL PROPERTIES OF CHROMIUM STEEL .. .. .	194
69. TYPICAL VALUES OF TOUGHNESS AND DUCTILITY OF ALLOY STEELS OF DIFFERENT TENSILE STRENGTH .. .. .	196
73. CURVES SHOWING THE FATIGUE RANGE AND OTHER MECHANICAL PROPERTIES OF AIR-HARDENING NICKEL CHROMIUM STEEL AFTER TEMPERING AT DIFFERENT TEMPERATURES .. .. .	208
74. THE MECHANICAL PROPERTIES OF STAINLESS STEEL AFTER TEMPERING AT VARIOUS TEMPERATURES .. .. .	213
75. CURVE SHOWING THE PERCENTAGE OF CARBON AT DIFFERENT DEPTHS BELOW THE SURFACE OF A CASE-HARDENED BAR .. .. .	217
77. TEST SPECIMEN TO SHOW CARBURISATION BY GAS .. .. .	223
78. TEST SPECIMEN FITTED IN CONTAINING TUBE .. .. .	223
79. DISTRIBUTION OF CASE ON TEST SPECIMEN AFTER CARBURISING .. .. .	223
80. CURVE SHOWING THE RATE OF ABSORPTION OF CARBON BY A STEEL DURING CARBURISATION WITH "HARDENITE" .. .. .	229
86. CURVE SHOWING THE CHANGES IN THE MECHANICAL PROPERTIES OF A STEEL PRODUCED BY VARYING AMOUNTS OF COLD WORK .. .. .	267
87. THE CHANGES IN THE MECHANICAL PROPERTIES OF COLD WORKED STEEL PRODUCED BY BLUEING AT DIFFERENT TEMPERATURES .. .. .	269
103. FRONT AND SIDE ELEVATIONS OF PROFESSOR ROBERTSON'S AXIAL LOADING SHACKLES .. .. .	303
106. DIAGRAMMATIC ILLUSTRATION OF THE HAMMER AND LIFTING GEAR OF THE STANTON REPEATED IMPACT TESTING MACHINE .. .. .	310

FIG.	PAGE
107. DIAGRAMMATIC ILLUSTRATION OF TURNING MECHANISM OF STANTON MACHINE .. .. .	310
108. SECTIONAL ELEVATION OF HAIGH ALTERNATING-STRESS TESTING MACHINE .. .. .	313
109. TEST PIECE TO BE USED IN HAIGH MACHINE .. .. .	316
111. DIAGRAMMATIC ILLUSTRATION OF PORTABLE DERIHON "HARDNESS TESTING" MACHINE .. .. .	320
113. SIDE ELEVATION OF JOHNSON BALL HARDNESS MACHINE <i>Inset at end of book</i>	
114. PLAN OF JOHNSON BALL HARDNESS MACHINE <i>Inset at end of book</i>	
117. ATCHERLEY BEND TESTING MACHINE AND PIN H ROUND WHICH STRIP IS BENT .. .. .	324
118. GENERAL ARRANGEMENT OF ATCHERLEY BEND TESTING MACHINE, SHOWING INITIAL POSITION OF STRIP .. .. .	325
119. JAWS OF ATCHERLEY BEND TESTING MACHINE .. .. .	325

# PLATES

No.		PAGE
1.	ETCHED CROSS SECTION OF INGOT SHOWING OUTER LAYER OF CHILLED STEEL, ALSO COLUMNAR CRYSTALS ..	349
2.	ETCHED SECTION OF INGOT SHOWING COLUMNAR CRYSTALS	350
3.	ETCHED SECTION OF INGOT SHOWING COLUMNAR AND FREE CRYSTALS .. .. .	351
4A.	ETCHED CROSS SECTION OF INGOT SHOWING DIFFERENT PROPORTION OF COLUMNAR AND FREE CRYSTALS ..	352
4B.	ETCHED HALF-SECTION OF INGOT SHOWING DIFFERENT PROPORTION OF COLUMNAR AND FREE CRYSTALS ..	353
5.	CROSS SECTION OF INGOT CAST HOT SHOWING COLUMNAR CRYSTALS EXTENDING FROM THE OUTSIDE TO THE AXIS OF THE INGOT .. .. .	354
6.	SECTION OF INGOT SHOWING EXISTENCE OF BOTTOM PYRAMID .. .. .	355
7.	ETCHED SECTION OF A SINGLE STEEL CRYSTAL SHOWING DENDRITIC FORMATION .. .. .	356
8.	EXTERNAL APPEARANCE OF SINGLE STEEL CRYSTAL ..	356
9.	LONGITUDINAL SECTION OF INGOT SHOWING AXIAL PIPE	357
10.	ETCHED SECTION OF INGOT SHOWING CONTRACTION CAVITIES HIGH IN NON-METALLIC IMPURITIES, LYING SYMMETRICALLY AROUND THE AXIS OF AN INGOT ..	358
12.	ETCHED SECTION OF FORGING IN WHICH THE CRYSTALLINE STRUCTURE OF THE INGOT HAS NOT BEEN OBLITERATED	359
13.	ETCHED SECTION OF A FORGING IN WHICH THE CRYSTALLINE STRUCTURE OF THE INGOT HAS BEEN ENTIRELY REPLACED BY A FIBROUS STRUCTURE .. .. .	360
16.	ETCHED SECTION OF CRANKSHAFT IN WHICH THE FIBRES OF THE STEEL IN ALL PARTS ARE PARALLEL TO THE AXIS OF THE SHAFT .. .. .	361
17A.	TRANSVERSE SECTION OF STEEL BAR SHOWING ROAKS ..	362
17B.	MICROSECTION THROUGH ROAKS IN ROLLED BAR ..	362

NO.	PAGE
18. MICROSECTION OF STEEL BAR SHOWING SLAG STREAK, × 25 DIAS .. .. .	363
19. SECTION OF FORGED STEEL SHOWING INTERMITTENT PIPE	363
20. SULPHUR PRINT OF SECTION OF AN INGOT THROUGH AXIAL PIPE .. .. .	364
21. SULPHUR PRINT OF A ROLLED BAR SHOWING SEGREGATION OF SULPHUR IN AXIS OF BAR .. .. .	365
22. SULPHUR PRINT OF FORGING SHOWING FRACTURE THROUGH REGION HIGH IN SULPHUR (DARK AREAS ARE THOSE HIGH IN SULPHUR) .. .. .	366
28. MICROSECTION SHOWING PEARLITE, × 500 DIAS ..	367
29. MICROSTRUCTURE OF A NORMALISED STEEL CONTAINING 0.30 PER CENT. OF CARBON, × 100 DIAS.. .. .	367
30. MICROSTRUCTURE OF HARDENED STEEL CONSISTING ENTIRELY OF SOLID SOLUTION .. .. .	368
34. MICROSTRUCTURE OF STEEL FULLY TEMPERED .. ..	368
35. MICROSTRUCTURE OF OVERHEATED CARBON STEEL (COOLED FAIRLY RAPIDLY) .. .. .	369
36. MICROSTRUCTURE OF THE STEEL SHOWN IN FIG. 35 AFTER NORMALISING, × 50 DIAS. .. .. .	369
37. MICROSTRUCTURE OF ANNEALED STEEL .. .. .	370
38. ETCHED CROSS SECTIONS OF DIFFERENT SIZED BARS OF CARBON STEEL HARDENED FROM THE SAME TEMPERA- TURE, SHOWING THE MASS EFFECT IN HARDENING ..	370
44. IZOD IMPACT TESTING MACHINE .. .. .	371
45. CHARPY PENDULUM IMPACT TESTING MACHINE .. ..	372
70. BILLETS OF ALLOY STEEL CONTAINING TYPICAL EXTERNAL LONGITUDINAL FLAWS .. .. .	373
71. ALLOY STEEL FORGINGS MADE FROM BILLETS SIMILAR TO THOSE SHOWN IN FIG. 70 .. .. .	374
72. DEFECTIVE FORGING MADE FROM APPARENTLY SOUND STEEL WHICH ACTUALLY HAD SURFACE DEFECTS ( <i>see</i> LONGITUDINAL CRACK AT BOTTOM OF CHANNEL SECTION)	375
76. COMPLETE ETCHED CROSS SECTION OF A BAR OF CASE- HARDENED STEEL, × 8 DIAS. .. .. .	376
81. MICROSECTION SHOWING CRACKS FOLLOWING FREE CARBIDE IN THE CASE OF A CASE-HARDENED PART .. .. .	377
82. MICROSTRUCTURE OF THE CASE OF A CASE-HARDENED PART AFTER CARBURISING AND BEFORE REFINING, × 50 DIAS. .. .. .	378

NO.	PAGE
83. MICROSTRUCTURE OF THE STEEL SHOWN IN FIG. 82, AFTER REFINING, $\times 100$ DIAS. . . . .	378
84. MICROSTRUCTURE OF THE CASE OF A CASE-HARDENED PART, SHOWING FREE IRON CARBIDE . . . . .	379
85. ETCHED CROSS SECTION OF A GEAR WHEEL TOOTH, SHOWING CRACKS SPREADING FROM FREE CARBIDE IN THE CASE . . . . .	380
88. MICROSTRUCTURE OF TYPICAL COLD WORKED STEEL . . . . .	381
89. MICROSECTION SHOWING THE EFFECT OF COLD WORK UPON THE CARBIDE IN A STEEL, $\times 400$ DIAS. . . . .	382
90. MICROSTRUCTURE OF COLD WORKED STEEL AFTER REHEATING TO $540^{\circ}$ C., SHOWING THE SPLITTING UP OF THE FERRITE GRAINS, $\times 400$ DIAS. . . . .	383
91. MICROSTRUCTURE OF COLD WORKED STEEL AFTER REHEATING TO $580^{\circ}$ C., SHOWING RE-CRYSTALLISATION OF FERRITE . . . . .	383
92. MICROSTRUCTURE OF COLD WORKED STEEL AFTER NORMALISING, $\times 100$ DIAS. . . . .	384
93. MICROSTRUCTURE OF COLD WORKED STEEL "GLOBULARISED" AT $650^{\circ}$ C., $\times 500$ DIAS. . . . .	384
94. MICROSTRUCTURE OF PATENTED STEEL BAR, $\times 300$ DIAS. . . . .	385
95. LONGITUDINAL AND TRANSVERSE SECTIONS OF BAR OF COLD WORKED STEEL WHICH HAS FRACTURED BY CUPPING . . . . .	385
96. PHOTOMICROGRAPH OF STRUCTURE OF STEEL CONTAINING 1.10 PER CENT. OF CARBON, NORMALISED, $\times 500$ DIAS. . . . .	386
97. MICROSTRUCTURE OF STEEL SHOWN IN FIG. 96 AFTER QUENCHING FROM $760^{\circ}$ C., $\times 500$ DIAS. . . . .	386
98. MICROSTRUCTURE OF HIGH SPEED STEEL, COOLED IN AIR FROM $1,000^{\circ}$ C., $\times 500$ DIAS. . . . .	387
99. MICROSTRUCTURE OF STEEL SHOWN IN FIG. 98, COOLED IN AIR FROM $1,250^{\circ}$ C., $\times 500$ DIAS. . . . .	387
100. ETCHED SECTION OF STEEL SHOWING A CRACK IN A FORGING, $\times 5$ DIAS. . . . .	388
101. SECTION THROUGH CASTELLATIONS ON CRANKSHAFT SHOWING CRACKS STARTING AT SHARP CORNERS . . . . .	389
102. SECTION OF STEEL THROUGH A CRACK, PRODUCED DURING HEAT TREATMENT, AND STARTING AT THE BASE OF A FORGING LAP . . . . .	390
104. BASE BLOCK OF IZOD IMPACT MACHINE WITH TEST PIECE IN POSITION . . . . .	391

NO.		PAGE
105.	GENERAL VIEW OF STANTON REPEATED IMPACT TESTING MACHINE .. .. .	392
110.	SWEDISH BRINELL MACHINE .. .. .	393
112.	WORKS MODEL OF DERIHON "HARDNESS" TESTING MACHINE .. .. .	394
115.	LEE REVERSE BEND TESTING MACHINE SHOWING INITIAL POSITION OF SPECIMEN .. .. .	395
116.	LEE REVERSE BEND TESTING MACHINE SHOWING POSITION OF SPECIMEN AFTER BENDING THROUGH 90°	396

## FOREWORD

By PROFESSOR W. C. UNWIN, LL.D., F.R.S.

*Past President of the Institution of Civil Engineers, etc.*

THOUGH Dr. Aitchison's treatise is essentially a metallurgical text-book, it breaks new ground in that it regards the subject principally from the point of view of the engineer. The descriptions of processes are brief, and the properties, especially the mechanical properties, of the products are fully dealt with, also the variation of those properties by heat or other treatment, and the defects which may occur in course of manufacture, for instance, from pathological conditions of the ingots.

The sweet simplicity of the time when wrought iron was the chief constructive material, and steel was only used for tools, cutlery, and similar purposes, has passed away. Now steel has superseded wrought iron for almost all purposes, and the metallurgist supplies a vast range of steel materials, widely varying in their properties, amongst which the engineer chooses one specially adapted to any particular application. This text-book deals in great detail with the modern alloy steels.



The quality of steel depends primarily on its chemical composition, but in the case of the more modern types the various operations, embraced in "heat treatment," to which the solid steel is subjected, and which modify its structure and properties, are almost more important. The author's view is that the chemical composition of steel is chiefly of interest to the metallurgist, who uses it as a means to an end. To the engineer it is of secondary importance. For him it is the strength, toughness, hardness, ductility, etc., which determine its value. Hence great attention is given by the author to the discussion of the methods of testing, and the meaning of test results. A very large number of test results for all types of steel are given, in a form directly comparable. The author's view of different conventional tests is, to some extent, original, and certainly interesting.

This is not the place for criticism, but many debateable points are discussed, and the author's views are well argued and supported by experimental evidence.

The classification of alloy steels according to their mechanical properties is very helpful in the selection of one suitable to any given purpose, and the author gives very full details of their behaviour under heat treatment, and of the reasons for preferring one type to another in different applications.

The illustrations, especially the series of microphotographs, add to the clearness and value of the book. It may be commended to all engineers as throwing a flood

of information on the varieties of steel now obtainable, the treatment to which they should be subjected, and the origin of the defects to which they are liable. It appears to me to be based on sound knowledge and an exceptionally wide experience. It is both scientific and practical in the best sense of those terms.

W. C. UNWIN.

## TO THE READER

### TENSILE AND NOTCHED BAR TESTS.

UNLESS otherwise stated, the tensile tests quoted in this book have been made upon specimens of which the gauge length and diameter fulfil the relationship  $L = 3.54 d$  (see p. 121.) The notched bar tests have been obtained upon 10 mm. square test pieces carrying the standard Izod notch (see p. 95).

### POSITION OF ILLUSTRATIONS.

It has not been found possible to insert the reproductions from microphotographs, etc., in juxtaposition to the references in the text. These illustrations are, therefore, with the exception of the large folding-plan insetted at p. 32, placed at the end of the book, and their positions indicated in the list of "Plates" on p. xxv *et sqq.*

# ENGINEERING STEELS

## CHAPTER I

### STEEL MELTING PROCESSES

MODERN steels are very various in their composition, mechanical properties, and uses. It may be assumed that all steel is produced for the benefit of the engineer, who stands as the great middleman between the metallurgist, who produces the raw material after rescuing it from the ground and winning it from its ores, and the general public, who ride in railway trains or motor-cars, who cross bridges, sail the seas in steamships, kill each other with engines of war, and wear the clothes made in the machines that the engineer has built. This is a mechanical age, and the engineer is ubiquitous. Almost all that the engineer builds is dependent upon steel for its foundation. His castings may be steel, he builds his bridges of steel, his locomotives are made to run upon steel rails, his machines are built up of steel forgings, and with steel his machine parts are tooled. On every hand, for almost every part, for nearly every kind of service, the engineer looks to steel, and in steel he finds his salvation. Is it wonderful, therefore, that steels are so various in their properties? The steel of the watchmaker's drill is of no use for the rails of a locomotive track, neither is the steel of a rifle barrel good for drilling armour. To meet all the requirements presented by this variety of uses, the metallurgist has to modify the simple steel,

and to fortify it here by alloying the iron with nickel, or chromium, or both; to strengthen it there by hardening, or to toughen it in yet a third instance by tempering. The philosopher's stone is not the quest of the metallurgist of this century, yet who would say that his fabrication of a high-speed drill or an armour plate from the ore is not a more worthy transmutation of metals than any that drew Paracelsus with its flattering deception and golden allure? The gold of the twentieth century is steel, and the alchemist of this age strives with his crucible, heated perhaps by electricity, but a crucible nevertheless, to turn the stones of the earth into steel, and, strange though it may seem, the processes for the manufacture of all the different varieties of steel are singularly alike, and these processes can be adequately described in brief without much particular reference to individual types or classes of steel.

It is not the purpose of this book to enter upon any full description of the different processes of steel manufacture. Such information is for the metallurgical student rather than for the engineer, who is probably content to be acquainted with the outlines of these processes in order to understand more fully the main characteristics of steels which have been made in different ways.

**The Crucible Process.**—Taking the methods of steel-making, which are at present in vogue, in the historical order of their development, the crucible process must be described first. This process was invented in Sheffield in 1742 by Huntsman, a watchmaker, who developed the process in order to be able to make more homogeneous watch-springs than had previously been produced. Crucible steel manufacture consists simply in melting together, in a crucible of refractory material, nearly pure iron along with charcoal, or some other form of carburising agent. When the charge is completely melted and mixed, it is cast into a mould. The carburising agent used is not always charcoal. Sometimes the carbon is added in the form of pure Swedish pig iron, which contains from

3.6 to 4.0 per cent. of carbon. At other times it is added as a material known as cemented bar. This material contains (in the form generally used for making crucible steel) from 1.2 to 1.5 per cent. of carbon, and is prepared by heating pure bar iron and charcoal together, at a temperature of about  $1,100^{\circ}\text{C}$ ., for several days. In the course of the heating the charcoal, in the form of one of its gaseous compounds, penetrates into the iron and carburises it. Naturally, the distribution of the carbon in the bar is by no means uniform, and it was the desire to secure the superior uniformity of carbon content that first led Huntsman to melt this cemented bar. By mixing suitable proportions of bar iron, Swedish pig iron, and cemented bar in the crucible charge, the desired carbon content can be attained in the finished steel.

In order to obtain sound ingots, it is customary to add to the molten charge a small amount of manganese. The manganese safely removes from the steel, as manganous oxide, a large proportion of the oxygen that may be present in the molten metal. Frequently, a little aluminium is also added to the steel just before casting, for the purpose of removing gases and promoting the soundness of the ingot.

Crucible steel ingots are usually quite small. A normal charge for a crucible is about 60 lb., and it is usual for one charge to provide one ingot. It is not uncommon, nevertheless, for two crucible charges to be cast into one ingot by the process known as "doubling," the contents of one crucible being emptied into those of another before pouring the combined charge into one ingot mould. Quite large ingots, or steel castings, have been made by the consecutive teeming into one mould of numerous doubled crucibles, but this practice definitely belongs to a bygone age, large steel ingots being made nowadays by processes quite different from that of crucible melting.

The most important modern use of the crucible furnace

is in the manufacture of high-speed steel. This material is almost invariably made by the crucible process, the requisite additions of tungsten and chromium (see Chapter IX) being added either with the charge or during the melting. Apart from this steel, the crucible furnace is used only for the production of the highest quality of fine tool steel. Razors, fine drills, taps, etc., are frequently, probably mainly, made from crucible steel, the cost of the raw material in such parts counting for relatively little in the cost of the finished article. For the majority of carbon steel parts the cost of crucible steel makes its use prohibitive.

In the process of crucible steel melting no purification of the charge is effected. The purity of the finished article is fixed by that of the original materials composing the charge. During the actual melting, the purity is diminished rather than improved, as there is generally a gain in the proportions of sulphur and silicon, whilst manganese is purposely added to the metal. These gains, where not made purposely, should not be very great, and usually are such as still permit of crucible steel being the purest form of commercial steel.

**The Bessemer Process.**—The next process to be developed, and the one which represents probably the most marvellous development in the whole history of metallurgy, is the Bessemer process. This process is entirely different from that of crucible melting. In the latter process the raw material is as pure as can be, and the whole operation is one of simple mixing. In the Bessemer process the raw material which is employed is singularly impure, being ordinary common pig iron, and the process is one in which the impurities are skilfully and carefully removed. It is not a simple mixing process, but rather one of purification. The pig iron which is to be used is melted, first of all, in a cupola furnace, being run down in the ordinary way with coke and

shaped vessel covered with a head, the shape of a truncated cone, in which the truncation has been effected obliquely. The base of the converter is pierced with a large number of holes which connect to an air blower. When the molten pig iron is in the converter, the air blast is turned on at a pressure of approximately 25 lb. per square inch, and is blown through the steel continuously. The air blast stirs up the molten metal very violently, and brings it all into intimate contact with the oxygen of the injected air. This oxygen combines with certain of the impurities in the pig iron, and removes them from the metal, either as gas, in the case of the carbon (which passes out with the residual air), or as liquid oxides, which rise from the metal and pass into the slag. The combination of the oxygen of the air with the impurities of the pig iron produces a considerable quantity of heat, sufficient, at any rate, to keep molten the pig iron and the steel, as it is formed, during the whole progress of the blow. The time occupied may be from fifteen to forty minutes, depending upon the nature of the charge and upon the method of working.

The technical side of steelmaking by the Bessemer process is fairly complicated, and will not be touched upon here. The degree to which the purification is effected can be judged readily from a comparison of the chemical analyses of the molten pig iron and the metal which has been completely blown—in a typical instance :

		PIG IRON.	BLOWN METAL.
Total Carbon	..	3·3 per cent.	0·08 per cent.
Silicon	.. ..	2·3     ,,	0·02     ,,
Manganese	.. ..	0·7     ,,	0·07     ,,
Sulphur	.. ..	0·06     ,,	0·063     ,,
Phosphorus	.. ..	0·06     ,,	0·063     ,,

The blown metal referred to above is the metal after



than those shown in the above analysis, which render it quite unsuitable for the purposes to which steel is customarily put. The most particular impurity is oxygen, which is present either dissolved as such, or as oxide of iron mixed with the steel. It may be readily imagined that the metal, after being agitated with such a large quantity of air, will have kept some of it in solution, and also, it is inconceivable that, whilst the other elements of the pig iron, such as the carbon, manganese, and silicon, have been oxidised, the iron has been left quite untouched. As a matter of fact, the great skill of the Bessemer steelmaker lies in stopping the operation at the critical moment which divides the oxidation of the impurities from the oxidation of the iron. Despite his skill, a certain proportion of oxide of iron is formed within the bath of molten metal, and, if allowed to remain, would render the steel absolutely unfit for forging or rolling. The oxide of iron would permeate the structure of the ingot in exactly the way that the wax enters into the structure of a honeycomb full of honey, and being of a brittle and fragile nature would cause either the hot or the cold ingot to break when stressed. Such an ingot could not be forged.

In order to get over this difficulty it is customary to add a deoxidising agent to the bath, and the one most usually employed is manganese. That element (added as ferro-manganese) can exercise a greater attraction for oxygen than iron, and therefore it reduces the oxide of iron, forming in its place metallic iron and oxide of manganese. The former goes into the bath of steel and the latter disappears into the slag. In order to ensure that the steel shall be thoroughly deoxidised, it is usual to add a distinct excess of manganese, and allow something like 1.0 per cent. of the element to remain unoxidised in the finished steel. After carefully removing the oxide of iron in this way, Bessemer steel is usually quite satis-

to the steel performs another function than that of deoxidising, and that is to add carbon. The addition of this element to the bath is essential if the blown metal is to be made into steel of any value, and the proportion of carbon has, furthermore, to be graded according to the uses to which the steel is to be put. All the commercial forms of ferro-manganese contain a greater or less proportion of carbon, and this necessarily goes into the bath when the alloy is added. The final steel is therefore quite different in composition from the blown metal, the following being a more or less typical composition of the finished product :

Carbon	..	..	..	..	0·30 per cent
Silicon	..	..	..	..	0·02 „
Manganese	..	..	..	..	1·00 „
Sulphur	..	..	..	..	0·063 „
Phosphorus	..	..	..	..	0·063 „

A reference to the compositions of the pig iron, and of the blown metal, or finished product, will show that the proportions of the elements, sulphur and phosphorus, have been increased slightly during the blow. This is due to the fact that the bulk of the metal bath is decreased by the removal from it of the carbon, silicon, and manganese, and also of a little iron, and that therefore the strength of the solution of sulphur or phosphorus is increased slightly by the “evaporation” of some of the solvent. This state of affairs refers, of course, to “acid” steel, with which the description given so far has been solely concerned. By making use of the “basic” process, a removal of sulphur and phosphorus, and particularly of phosphorus, can be effected. It will be well at this point to indicate the essential features of difference between the acid and the basic processes. The description will be simplified by referring principally to the removal of phosphorus.

During the blowing of air through the molten iron in

the Bessemer converter, it is quite certain that the phosphorus in the bath is oxidised to an oxide of phosphorus. Since the phosphorus in the non-oxidised form is always found in the steel at the end of the "acid" blow, it is equally certain that the oxide of phosphorus, when formed, is reduced back again to the element by one or other of the more easily oxidisable elements present, e.g., silicon or carbon. The oxide of phosphorus is an acid oxide, just as are the oxides of silicon, sulphur and carbon. The only two basic oxides which can be produced in the Bessemer bath are those of manganese and iron. The liquid slag on the top of the metal, therefore, relies chiefly for its basic oxide upon the oxide of iron produced during the blow. The combination between oxide of iron and oxide of phosphorus is comparatively loose, and the basic oxide of iron cannot exercise a greatly protective influence over the oxide of phosphorus in the event of a predatory attack upon it by some reducing element, such as silicon. This is probably due to the weakly basic nature of the oxide of iron. If, however, some other and more powerful protector be provided for the oxide of phosphorus in the form of a strong basic oxide, it may be possible to prevent the reduction of the oxide of phosphorus by these predatory reducing elements. Such a basic oxide is lime, and the compound formed between lime and oxide of phosphorus (phosphate of lime, calcium phosphate) is sufficiently stable not to be attacked or reduced. In order, therefore, to make the removal of the phosphorus possible, lime must be added to the slag which is floating upon the top of the steel. Such a proceeding, however, introduces a further possible complication.

The linings of the Bessemer converter have necessarily to be of some definitely refractory material, as they have to withstand very high temperatures indeed. At these high temperatures chemical reactions of most types take place easily, and the furnace lining itself is exposed to the full force of any reactions which might occur. In

the steel there is nothing which is likely to act upon the material of any refractory lining, but the same cannot be said of the slag. If the slag contains any preponderating proportion of basic substance, and the lining contains, similarly, a large proportion of acid substances, the two are likely to interact, and do so. This interaction results in the rapid and destructive erosion of the lining of the converter. The erosion will occur in a furnace lined with silica bricks, by the action of the oxide of iron in the slag, but the attack is rarely very pronounced, because the proportion of oxide of iron in the slag is usually not sufficiently high. If, however, the slag be made pronouncedly basic by the addition of lime, with the object of effecting the removal of phosphorus, the attack on the silica lining becomes intense, and the furnaces could never last long enough to make the basic process worth while. To overcome the difficulty it is customary to provide this class of furnace with a basic lining, e.g., made of magnesite. Upon such a lining the bases in the slag have no destructive action, and the requisite proportion of lime, etc., can be added to the slag to effect the removal of the phosphorus.

The addition of lime to the slag really constitutes the essential difference between the acid and the basic processes for the manufacture of Bessemer steel. By the developments of the basic process which have occurred, it is possible to utilise pig irons which are quite unsuited to the manufacture of steel by the acid process, as can be readily seen from the analysis of a typical basic pig iron and basic steel:

		PIG IRON.	STEEL.
Total Carbon	..	3·3 per cent.	0·3 per cent.
Silicon	..	0·3    ,,	0·12    ,,
Manganese	..	0·75   ,,	0·85    ,,
Sulphur	..	0·15   ,,	0·04    ,,
Phosphorus	..	1·50   ,,	0·025   ,,

The weight of metal blown at one time in a Bessemer converter varies from two to twenty tons, and ingot

varying from half a ton to three tons in weight are customarily made.

**The Open-hearth Process.**—This process, known also as the Siemens or Siemens-Martin process, is similar to the Bessemer process, in that it effects a great purification of the metal originally charged and melted. The charge for an open-hearth furnace is usually a mixture of steel scrap and pig iron. When such a charge has just melted in an acid furnace it will have an average composition of :

Total Carbon	..	..	..	1.5 per cent.
Silicon	..	..	..	0.25 „
Manganese	..	..	..	0.25 „

The sulphur and phosphorus will be present in approximately the same proportions as in the original charge.

The actual type of furnace employed is accurately described by its title, i.e., open hearth. It consists of a shallow basin, usually elliptical in shape, the depth of which is rarely more than one-tenth of its length. This basin is suitably lined with refractory material, and covered with a fairly low roof built of silica bricks. The heating of the furnace is effected by burning hot producer gas and hot air, intimately mixed, in the space between the roof and the basin. The products of combustion are taken away to heat regenerative chambers in which, by suitably reversing the flow of the gases, the air and gas to be used for the combustion are later pre-heated, in order to produce the maximum temperature in the combustion chamber. By a proper design of furnace and regenerators, and the use of a good fuel, a temperature as high as 1,700° C. can be attained in the space over the bath.

When the charge in the furnace has melted, the purification process is commenced, and this is carried on by the formation of a slag on the metal, to which slag oxide of iron, in the form of iron ore, is added. The oxide of iron reacts with the impurities in the bath, the carbon

being oxidised to a gaseous oxide and passing away, whilst the manganese and silicon go into the slag as liquid oxides. Naturally, such a purification does not proceed at a very rapid rate, more particularly as regards the carbon. A time varying from five to eight hours is quite normal for the complete purification, if the finished product is low carbon steel. Since the removal of the carbon takes place slowly, and also since this element is the last to be oxidised, it is quite practicable to interrupt the process of purification at any desired stage, i.e., at the time when the percentage of carbon desired in the finished steel has approximately been reached.

When the complete purification and the removal of carbon to the desired extent have been effected, suitable additions of ferro-manganese and ferro-silicon are made to the steel, after which it is cast into ingots. The weight of steel made in an open-hearth furnace in one charge varies greatly, being in a normal furnace from twenty to fifty tons. The ingots made from open-hearth steel vary from half a ton to one hundred tons in weight.

The reactions involved in the manufacture of steel by the open-hearth process are much quieter and less hurried than those prevailing in the Bessemer process. The operations are more thoroughly under control and the products are usually better in consequence. The open-hearth furnace may be either acid or basic, just as the Bessemer furnace may be, and the difference between the acid and the basic furnaces is the same in each process. As the supply of pig iron of a composition suitable for the manufacture of steel by the acid process is decreasing in comparison with that suitable for making steel by the basic process, the amount of basic open-hearth steel is obtaining a preponderating position in the world's supply of steel, from which it is not likely to be ousted.

**Electric Steel Melting.**—The fourth and most recently developed process of steel manufacture is that by the electric furnace. As a matter of fact, this is not a process, but several processes, there being many different

types of furnace, each having its own peculiarities, which necessarily influence the steelmaking process within it. It is quite outside the scope of this book to describe or to discuss the different kinds of furnace, or the various ways in which they are operated. Such a subject requires a volume to itself. It must be sufficient to indicate in a brief manner the many forms of electric furnaces used.

Probably the earliest type of furnace used on anything like a commercial scale was the direct arc furnace, in which an arc is struck across electrodes which lie slightly above the level of the metal, the heat produced being, therefore, made available to the metal bath chiefly by radiation. The first advance from this was the furnace in which the arc is not struck directly from one electrode to the other, but from one electrode to the slag, and then through the slag (lying on the steel) to the other electrode, by arc from the surface of the bath. In this method of heating the steel receives the benefit of the heat produced by direct radiation from the arcs, and also of the heat engendered by the resistance offered to the passage of the current through the metal and the slag. The next development was the use of an electrode (or several electrodes) buried in the bottom of the furnace, so that the current passes from the top electrode through the bath to the electrode buried in the base of the furnace. This form appears to give as good results as any, and probably there are more of this type of furnace at work in this country than of any other kind.

A collateral development lay in the form of a furnace known as the Induction Furnace. In this furnace the bath (in its simplest form) is in the shape of a fairly narrow ring. In the centre of the ring are the primary coil and armature. The passage of a suitable alternating current through this primary circuit induces in the ring of metal lying in the bath a sufficiently large current to generate enough heat, from the resistance offered by the iron to its

steelmaking operations that are to be carried out. Combination furnaces are sometimes built in which induction heating is combined with the arc, so that the effects of both kinds of heating can be utilised. The induction furnaces, in either their plain or their highly developed state, have never come into such successful use (judged by the number in operation) as furnaces of the plain arc type.

It is hardly necessary to say that in their electrical features the furnaces vary immensely, in the number of electrodes, the phase of the current, and all the details which the skilful and resourceful electrical engineer can alter successfully in order to effect improvements. Almost equally numerous are the variations in furnace design, for the use of electricity, as a means of heating, places before the designer of steel-melting furnaces, problems which are not met with in the Bessemer or the open-hearth furnace.

Practically without exception the modern electric furnace is lined with basic materials, so that the steel-making process in the electric furnace is a basic one. This enables phosphoric charges to be employed and purified. Purification is usually achieved in the arc type furnaces, and is attempted less frequently in the induction furnaces. In view of the cost of the process, electric furnaces are generally employed upon the production of alloy steels, nickel chromium steels in particular. High-speed steel has been made quite successfully in the electric furnace, but it seems unlikely at present that this method of manufacture will completely oust the crucible furnace from its present position in the manufacture of high-speed steel.

The electric furnace usually melts from two to ten tons as a normal charge. As a method of steel manufacture it is not cheap, its cost lying midway between that of the crucible and that of the open hearth. Naturally the cost varies greatly according to the price of the electricity. When the power can be produced at a low



rate, as in parts of Norway or near Niagara, electric steel-making becomes almost, if not quite, as cheap as the open-hearth process. On the other hand, where the power has to be produced by the burning of coal and the raising of steam, and is, therefore, relatively costly, the charges for electric melting may rise as high as those for crucible melting. Taking an average cost of electricity on the one hand and of solid fuels on the other hand, the four principal steelmaking processes arrange themselves in the following order of decreasing costliness :

- (i) Crucible melting.
- (ii) Electric melting.
- (iii) Open hearth and Bessemer.

It is difficult to give any actual costs for the different processes, which will bear close inspection, since the four types of furnace do not, except for special reasons, produce the same type of steel, and to compare the costs of a furnace producing steel rails with those of a furnace producing "cast steel" drills would be distinctly misleading. It is not easy, either, to say whether the open-hearth or the Bessemer process is the cheaper. In some localities the Bessemer is cheaper, but in many others the open-hearth process is decidedly more economical. This is not solely a question of the price of pig iron and raw materials, or of initial charges, but involves such highly important matters as the percentage of waste, quality of ingots, etc. A truly representative estimate of the cost of a steelmaking process can be formed only on the basis of the weight of *sound* steel produced thereby. The yield of sound steel from a well-conducted open-hearth plant is distinctly higher than that from an equally well-conducted Bessemer plant.

The Bessemer furnace is used exclusively for the common types of steels which have to be manufactured chiefly in large quantities. Much the same type of steel is made at a more or less similar cost in the basic open-hearth

or Siemens furnace. The better types of plain carbon steel are manufactured in the acid open-hearth furnace. The structural alloy steels, such as nickel and nickel chromium steels, are mostly produced in the acid open-hearth, or in the electric furnace. The crucible furnace is mainly concerned with the production of high carbon steel, such as is used for fine tools, cutlery, razors, etc., and of high-speed and magnet steels.

The various forms in which the steel is actually produced or fashioned are dealt with in the next chapter.

## CHAPTER II

### THE CASTING AND WORKING OF STEEL

THE greater part of the steel used by the engineer is first cast from the steel-melting furnace into ingots. These may vary in size from the half-hundredweight crucible steel ingot to the 100-ton monster, which receives the charge of two or more open-hearth furnaces. In dimensions they vary from a three-inch square to perhaps a forty-inch octagon. Naturally, the details of casting of all this variety of ingots are not the same in all instances, but the underlying principles are not changed appreciably by the size of the ingot. It might be thought that the casting of ingots is a subject of but little importance to the engineer, and that it belongs exclusively to the domain of the metallurgist. So far as the science and art of the successful working of the process is concerned this is doubtless true, but it is a fact, nevertheless, that the properties of the original ingot, in a very large proportion of instances, decide whether or not the steel part used by the engineer is good or bad. It is certainly the author's experience that faulty ingot manufacture is responsible for innumerable troubles experienced by the engineer during the subsequent history of the steel. This being so, it is of obvious importance to the engineer to comprehend, at any rate, such details connected with the casting of steel ingots as may be of importance in the production of sound steel. The purely metallurgical side, where it can be separated from the engineering, will be ignored in this discussion.

The simplest way of dealing with this subject will be to follow out in detail the solidification of the steel in an ingot mould. Whether the steel is poured into the mould from the top or the bottom does not matter very much, in so far as the discussion is concerned. In either case the steel has necessarily to fill the mould from the bottom upwards. As soon as the liquid steel strikes the bottom of the mould, or as soon as it comes into contact with the cold sides of the mould, solidification commences. The cold surface of the mould chills the liquid steel that comes first of all in contact with it, and this part of the steel becomes solid at once—almost instantaneously. The result is that the steel has no time to assume any very definite crystalline form. Any slag, dirt, or loose material from the sides of the mould, which happens to be floating in this portion of the steel, becomes entrapped by the sudden solidification of the steel. This layer of suddenly chilled steel is not very thick (see Fig. 1), since the very rapid chilling effect of the mould cannot operate after a comparatively thin layer of steel has solidified. Within this suddenly chilled envelope the freezing of the steel continues more slowly, and the metal has the time and opportunity to form more clearly defined crystals. The subsequent crystallisation will go forward from the thin shell of solidified steel lying round the inside surface of the mould, the crystals growing inwards from this layer of solid steel, that is to say, from the solid root into the residual liquid. The whole of the surface of the original thin shell is an active cooling medium, so that a large number of crystals will start from a limited area of envelope. This being so, the crystals, if they are to grow at all, will extend themselves in that direction in which there is the least resistance to their growth. This direction cannot be sideways, for they will rapidly be stopped from any extension in that direction by collision with the adjacent crystals. The growth of the crystal must therefore necessarily be lengthwise, i.e., inwards from the original shell of solid

metal, and, therefore, at right angles to the side or bottom of the ingot mould.

The second stage, therefore, in the solidification of the ingot, is the production of a large number of crystals (Fig. 2) growing inwards from the walls and base of the ingot mould and into the residue of fluid steel. These crystals, being so numerous, are necessarily of small cross-section compared with their length; they are, in fact, more or less needle-like or columnar in character (see Fig. 2). The columnar crystals will grow forward into the fluid metal until one of two things happens to put a stop to their further extension. The first possible preventive is the cessation of the supply of fluid metal, i.e., the complete solidification of the steel, and the second is the meeting by the crystal of some other crystal or solid obstruction. The first-named cause of cessation is not very likely to happen unless the crystals have extended to the middle of the ingot, but the second may, and does, occur fairly often, for the following reasons. Whilst the steel is passing from the furnace into the mould a certain amount of slag, dirt, etc., is bound to be mixed up with it. The actual quantity is probably not very large, neither is the amount of dirt, etc., which is collected by the molten steel from the sides of the ingot mould. Nevertheless, however small the actual quantity may be, some there is, and, being foreign to the steel, each particle of impurity tends to act as a nucleus for the solidification of the molten metal. These numerous nuclei are most likely to remain in the fluid interior of the ingot during the early stages of the solidification, i.e., the formation of the columnar crystals. Another source from which centres of crystallisation are provided, is the crusts or solid lids which form upon the upper surface of the steel as it rises in the mould. As the steel comes up the mould it is exposed, at any rate in part, to the atmosphere, which chills the top crust of metal and partially solidifies it. As the steel rises further, this crust becomes broken, and falls back into the fluid metal, in which it sinks, and, during

the early stages, no doubt melts again. A stage is reached, however, when the broken crust falling into the ingot does not re-melt, but is disseminated as solid pieces through the fluid kernel. Together with the other solid particles described above, these pieces of broken crust act as centres of solidification for the remaining fluid steel. Round each solid particle, which may be quite small, the fluid steel begins to solidify and to crystallise.

The same result would be obtained within the ingot even if there were no foreign particles to act as nuclei for the crystallisation. This is due to the fact that when the temperature of the metal in the interior of the ingot has fallen to a certain point, the steel tends to form crystals in other ways than by increasing the growth of the columnar crystals already started. The temperature of the layer of steel around the inner ends of the columnar crystals is so near to the freezing-point that solidification "cannot wait" for the slower growth and formation of the comparatively large and perfect columnar crystals, but must proceed as best it can. It does so, therefore, by the formation of a large number of small crystals, just as would occur if the conditions described above were in operation.

Since the crystals forming in the kernel of the ingot have equal freedom of growth in all directions, they do not arrange themselves in any particular way in relation to the sides of the ingot mould, as happened with the first formed columnar crystals. They can grow more or less according to their wishes, and the only hindrance to their extension in any direction is by collision with a neighbouring crystal. The result is that the core of the ingot becomes filled with a higgledy-piggledy arrangement of short crystals having no fixed orientation. This collection of stumpy crystals will grow at more or less equal rates in all parts of the fluid interior, and at any particular level in the ingot (except in the uppermost parts of the ingot, where the layers of steel are affected by shrinkage and the formation of pipe, etc.) will extend

almost completely across the whole of the section of the ingot, which is not already filled with the columnar crystals growing inwards from the original shell of the ingot mould. The formation of the free stumpy crystals in the interior of the ingot necessarily puts a stop to the growth of the columnar crystals. The latter can only grow so long as there is an adequate supply of fluid metal, and if this supply is cut off by the solidification of the free crystals in the core, the columnar crystals cannot extend themselves. Consequently, the thickness of the layer of columnar crystals will be determined by the time which elapses before the first of the free crystals is formed, and the latter will form in a layer round the innermost surfaces of the columnar crystals (Fig. 3).

The formation of the central core of crystals marks the completion of the solidification of the ingot, which, therefore, consists of three zones of different type and character. On the outside (to recapitulate) is the thin shell of rapidly chilled steel, having no marked crystalline form, but containing entrapped foreign matter. Next to this thin shell, and growing out of it, is a layer of varying thickness of columnar crystals, needle-like in shape, which always form at right angles to the nearest cooling surface, i.e., the sides of the mould, whilst the third zone, lying as the kernel of a nut, consists of a higgledy-piggledy collection of small crystals, without definite or uniform orientation. (These crystals in the core are referred to as the "free" crystals.) The outer zone is seen well in Fig. 3, whilst in Fig. 4 the existence and form of the columnar and free crystals are clearly portrayed. The characteristics of these three zones will emerge from the subsequent considerations.

The sections of ingots shown in Figs. 3 and 4 can be considered as representative of all ingots. They are typical ingots, but the proportions of columnar and free crystals shown in these sections do not occur in every ingot. A moment's consideration will show how obviously true this is. It was demonstrated above that the columnar

crystals would continue to grow until they were stopped by collision either with the free crystals of the core, or with each other. It was also shown that the crystals of the core form at a comparatively rapid rate when the temperature of the remaining fluid steel has fallen approximately to the freezing-point of the steel. Evidently, then, the freezing of the free crystals will be delayed much longer if the steel, when originally poured into the mould, is hot, i.e., is at a temperature considerably above its freezing-point, than when it is cast cold. Delay in the freezing out of the free crystals means a further extension of growth of the columnar crystals. If the steel be poured hot, then the columnar crystals will grow to a greater length than if the steel is cast cold, and, if it be cast hot enough, they will occupy the whole of the cross-section of the ingot. An ingot in which this has occurred is shown in Fig. 5, and the section shows that the columnar crystals proceed from the skin of the ingot to its axis.

It is desirable to investigate what happens at the base of an ingot when the steel is cast at a high temperature. The columnar crystals in this part are growing, not only from the sides of the ingot mould, but also from the base plate, and they are growing perpendicularly to all these five surfaces. Evidently, the sets of crystals growing out from the different faces will mutually interfere with each other after they have grown to a certain length, those growing upwards from the base meeting those growing outwards from all the four sides. The result is the formation of a pyramid, composed entirely of columnar crystals, in the bottom of the ingot, as shown in Fig. 6. The influence of this pyramid upon the properties of the ingot will be described later. If the conditions of casting are such as permit of the growth of only a limited length of columnar crystals, the pyramid will be truncated and will be surmounted by free crystals indistinguishable from those in the rest of the ingot. Even in such an ingot, the planes of contact of the five sets



of columnar crystals round the faces of the truncated pyramid will exist and be clearly marked.

It is desirable now to give some further indication of the internal structure of the columnar crystals, as upon a clear understanding of their nature depends the true appreciation of those properties of the ingot which result from the formation of these crystals. The molten steel which is poured from the furnace is a liquid solution, and is therefore quite homogeneous. As it is not a pure substance, but a mixture (i.e., a solution), it necessarily does not freeze completely at one definite temperature, but over a range of temperatures (compare the water-salt and the lead-tin systems, p. 43) of perhaps  $150^{\circ}\text{C}$ . During the process of solidification, a certain part of the material freezes out sooner than the rest, and takes the form of dendrites or dendritic crystals, as shown in Fig. 7. All the foreign matter (or practically all of it) is pushed by the freezing steel to the outer surface of the dendrites. At a certain temperature, which marks the end of the freezing, the whole of the remainder of the steel, i.e., the residual liquid metal, solidifies, and does so by "filling in the background," and by creating a matrix or setting for the dendrites already formed (see Fig. 8). During this freezing the greater part of the non-metallic impurities are again pushed outwards to the skin of the crystal. When the steel has finally solidified, and has produced a columnar crystal (as shown in Figs. 7 and 8), this crystal really consists of three parts, the skeleton of dendritic matter, the background or matrix of material very slightly different in composition from the dendrites, and a skin of non-metallic impurity. This skin separates and keeps apart the neighbouring columnar crystals. In addition to the outer skin of foreign matter there is also a certain amount (though it is probably not very great) of similar material surrounding the dendrites in a discontinuous layer, and separating them partially from the material of the matrix. The amount of non-metallic material in this position is, how-

ever, very slight, in comparison with that lying round the outside of the complete columnar crystals.

By reason of this skin of non-metallic matter, and also as a consequence of the fact that each columnar crystal has started to grow around a different axis, each columnar crystal can be accurately conceived as being a separate and distinct entity, and as possessing comparatively little cohesion with its neighbours. This applies both to the contact between the sides of contiguous parallel crystals and also to the "point" contacts at the ends of the crystals of different sets, i.e., those growing from different sides of the ingot mould. Probably, in the latter region, the lack of cohesion is more marked than in the former, since the columnar crystals, in growing forward into the fluid metal, tend to squeeze out the foreign matter from between them and to push it forward into the ingot so that it collects at the front ends of the columns. There are, therefore, definite planes of weakness which lie diagonally in the ingot wherever the crystals are columnar (see Fig. 5). The same lack of cohesion exists to a less extent between the individual free crystals, and it is bound to be more or less marked at the junction of the columnar and the free crystals, particularly as this zone contains the forward ends of all the columnar crystals, and their accretion of impurities. One exactly similar zone exists, of course, all round the pyramid (truncated or complete) which forms in the bottom of the ingot. All these positions, therefore, mark the existence, within the ingot, of planes or zones of weakness in which the inter-crystalline cohesion is at a minimum.

The planes and zones of weakness within the ingot are of great importance because they become the centres of certain definite defects of greater or less dimensions within the ingot. It is important, therefore, to know what positions in the ingot these weak places occupy. The main cause of the defects is the contraction which takes place during the cooling down of the ingot. This contraction is of two kinds—fluid and solid. Both types

require careful consideration, since they are responsible for many, if not most, of the defects found in ingots. The first type of contraction—fluid—can be understood easily. As the steel freezes, it contracts in volume by a definite amount, and, as the steel freezes from the outside inwards, there is a tendency for it to shrink towards the exterior of the ingot. The fluid metal in the middle tends, therefore, to sink lower in the mould than it otherwise would, in consequence of the cavity left in the middle by the contraction of the solidifying steel towards the outside of the ingot. The downward flow of the fluid metal fills in the cavities formed by the contraction at or near to the bottom of the ingot, but it usually happens that, at the top of the ingot, a cavity is formed round the axis of the ingot, which remains empty because there is no metal left above it to flow down and fill it (see Fig. 9). This cavity results in the formation of the familiar “ pipe ” and all the evils which attend it. The above explanation should make it quite clear that the formation of pipe is something which cannot be prevented. It is bound to occur to a greater or less degree, even in the best ingots, and the only thing that the steelmaker can do is to control the pipe, as far as possible, by confining it to that part of the ingot which is to be cropped and scrapped.

Closely allied to the creation of pipe is the production of zones of weakness around the axis of the ingot. The formation of these zones can be easily understood from the section of an ingot shown in Fig. 10, and the diagram in Fig. 11, which indicates roughly the manner in which the freezing of the layers of an ingot occurs. This diagram is intended to show that (after the formation of the columnar crystals) the free crystals may be considered to freeze out for a certain distance, and then that a certain layer forms as a roof. This layer does not immediately freeze quite solid (see p. 43), and by the contraction, both fluid and solid, below it, caves in and becomes cup-shaped. Although it has not become quite solid, it has acquired sufficient rigidity to prevent the upward

flow of the non-metallic impurities, such as slag and sulphides, which are, consequently, trapped below it. When the roof caves in and becomes cup-shaped, the inclusions of impurities also slope downwards, and, by the last dying gasp of the fluid contraction, fall into the shape shown in the section in Fig. 10, this shape being that of an inverted blunt-nosed cone. In the ingot a series of such inverted cones is to be found from the bottom to the top, producing in the section of the ingot a herring-bone arrangement. These inverted cones are

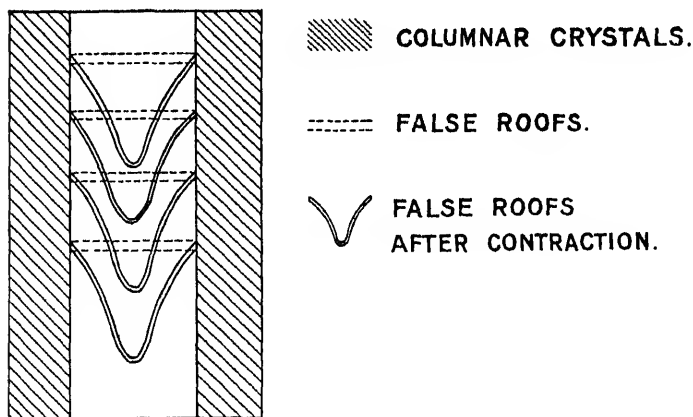

FIG. 11.—DIAGRAMMATIC REPRESENTATION OF THE METHOD OF FORMATION OF THE CONTRACTION CAVITIES SHOWN IN FIG. 10.

necessarily rather rich in non-metallic impurities, which means, in turn, that the crystals within the impure zone of the cone are bound together rather loosely.

Such, then, is the condition of a *sound* ingot after it has been cast and has just solidified. The contraction of the ingot has, however, by no means ended. The steel has to contract in accordance with the ordinary laws of the thermal contraction and expansion of solids. Assuming that the temperature of the ingot, at the moment of complete solidification, is  $1,300^{\circ}\text{C.}$ , the

is about 5 per cent. This contraction cannot be avoided, and must be accommodated somewhere. It cannot be taken up by the formation of further pipe, because pipe is a function of fluid contraction, not solid. Neither can it be accommodated by the shrinkage inwards of the outer skin. Such shrinkage will occur, but only to a limited extent, because the outside of the ingot is a great deal cooler than the interior. This means that it will contract less during the final cooling than the interior, and also it means that, being cooler, it is stronger and, therefore, less likely to yield abnormally under contraction stresses. The majority of the contraction, therefore, must take place and be accommodated inside the ingot. Also, since the various parts of the ingot, and even the single crystals, are separate entities (to all intents and purposes), each crystal will contract or tend to contract as a unit, and, therefore, to pull itself away from the surrounding units. This means that within the ingot the solid contraction exercises a powerfully disruptive tendency which will show itself most markedly in the weakest zones of the ingot, i.e., in the zones where there is the least cohesion between the crystals or the units. The position of these weakest zones has already been indicated, being respectively between the individual columnar crystals, between the sets of columnar crystals, between the columnar and the free crystals, and in the cones high in impurities in the free crystals. The tendency, therefore, of the contraction forces, is to pull the crystals away from each other at all these places, and to produce definite contraction cavities. These cavities will be referred to again, later.

It has now been shown how a steel ingot is formed, and how it solidifies into different portions and develops varieties of crystallisation in the different parts. As the engineer does not usually employ ingots as raw material, it is desirable to follow out the influences of the various crystalline formations upon the rolled or forged products

which are the ordinary forms of raw material used by him. It is unnecessary to state that the forging operation changes the external shape of the steel, and, since the ingot, as the starting-point for a large proportion of the forgings and drop forgings which are used, is far too large to be handled, it is first of all broken down to a more convenient size. This means that it is usually elongated parallel to the major axis of the ingot, and consequently reduced in cross-section. From this longer bar of smaller section than the ingot, suitable lengths are cut off to provide the material for one or more forgings. The selected piece is then formed, either under the hammer, or in the dies of a drop hammer, to the final shape. As ingots are commonly made fourteen or fifteen inches square, and as there are thousands of forgings or drop forgings made with a cross-section, in places, of only half an inch square, it is evident that the change of external shape in the steel is immense. A change of external shape of this, or indeed of any magnitude, must have a pronounced effect upon the internal structure of the steel in the ingot. The effect will depend upon the extent to which the steel has been forged, or rather the extent to which the shape of the steel has been changed.

The effect of working upon the structure of the steel within an ingot, is to distort the individual crystals, whether they are columnar or free. If it is assumed that the working is such as will elongate the ingot parallel to its major axis, then the columnar crystals will first of all be bent and perhaps flattened out, i.e., squashed down towards the outside layers of the ingot, and then, under the influence of the work, may be gradually turned so that their axes lie more or less parallel to the direction of elongation of the steel in the ingot. This degree of distortion requires the application of a considerable amount of work, and unless the requisite amount of work has been done, the dendritic formation of the interior

the dendritic formation of the columnar crystals is not always destroyed or removed. It is often possible to detect, on a scale much smaller than exists in the ingot, definite traces of the original dendritic structure. The permanence of the columnar crystals certainly depends to some extent upon the magnitude, nature, and arrangement of the non-metallic impurities around the crystals, and it is quite certain that under certain circumstances it is practically impossible to remove entirely the original columnar structure of the ingot, even after rolling. The typical two final conditions can be seen in the sections of forgings given in Figs. 12 and 13. In Fig. 13 it is evident that, to all intents and purposes, the steel consists, not of crystals as customarily conceived, but of parallel "fibres," each fibre being very long in proportion to its breadth. The same effect is produced in the free crystals as in the columnar crystals, though in the free crystals the transition to the "fibre" condition is easier than in the columnar, because of the absence in the free crystals of any definite orientation perpendicular to the sides of the ingot. As a result, there is less need to turn the axis of the crystal, and the transformation into the fibre takes place more easily.

It might be thought at first sight that, during the forging operations, the crystals—either columnar or free—would lose their identity, and would merge one into the other, or, in other words, would weld up. This would seem to be a reasonable thing to expect, were it not for the outer skin of non-metallic impurity around the crystals. This skin protects the crystals from merging one into the other, although the skin itself may be of almost impalpable thickness. It is also possible that there is a slight difference in composition between the dendrites and the background (possibly in the phosphorus content), and that this difference is not overcome (and metal of uniform composition produced) during a normal time of heating at the forging temperature. Whatever the reason, the result is that, in a forged steel in which there is a

well-developed fibre, there is a thin layer (which may be discontinuous, and may in reality also be a series of smaller and thinner fibres) of non-metallic inclusions around each fibre of the steel, which, to a certain extent, keeps them apart. This fact has a distinct influence upon the mechanical properties of the forged steel.

The section of a forging shown in Fig. 13 indicates clearly that the forged steel has developed a grain something like that formed in wood, the fibres of the steel lying in the forging in a manner somewhat similar to the

TABLE 1.

THE MECHANICAL PROPERTIES OF STEEL CUT FROM AN INGOT IN THREE DIFFERENT DIRECTIONS AT RIGHT ANGLES.

Direction of Axis of Test Piece.	Heat Treatment.	Max. Stress, tons per sq. in.	Elongation, %.	Reduction of Area, %.	Impact, ft.-lb.
A	As cast	62.0	4.0	1.5	2
B	As cast	64.3	6.0	1.5	2
C	As cast	62.5	3.5	1.5	3
A	Cooled in air from 1,100° C.	74.7	5.0	7.5	2.5
B	Cooled in air from 1,100° C.	77.9	5.0	7.5	2.5
C	Cooled in air from 1,100° C.	74.3	7.5	10.5	2.5
A	{ Quenched from 830° C. in oil, and tempered at 600° C. and cooled in water }	68.0	11.0	19.8	10
B		73.5	10.0	23.5	9.5
C		68.4	10.0	26.5	8

arrangement of the fibres of wood in a plank. Without pressing the simile too far, it may be convenient to speak of the "grain" of the steel in the same sense as the term is applied to timber, so that a mental picture may easily be formed of any forging, and the disposition of the fibres or forged crystals within it.

In the interior of an ingot, i.e., in the free crystals, which after all compose the greater part of the majority of sound ingots, there is no grain at all. It would be expected that the mechanical properties of steel in this



form would be the same in all directions, i.e., that they would be independent of the direction in which the test sample was cut. The truth of this assumption can be seen from the figures given in Table 1, the directions A, B, and C, being respectively parallel to the three axes of the ingot.

If similar mechanical tests are made upon forged steel the effect of the direction of the grain in the test piece becomes very evident. Suitable figures are quoted in Table 2 of the results obtained from test pieces cut along and across the grain of the steel.

TABLE 2.

THE MECHANICAL PROPERTIES OF SPECIMENS OF STEELS CUT PARALLEL AND TRANSVERSE TO THE DIRECTION OF DRAWING OUT DURING FORGING.

Orientation of Axis of Test Piece to Fibres of Forged Steel.	Heat Treatment.	Max. Stress, tons per sq. in.	Elongation, %.	Reduction of Area, %.	Impact, ft.-lb.
Parallel	As forged	97.2	11.7	36.9	10
Transverse	As forged	84.5	4.2	12.5	5
Parallel	Quenched from 830° C. in oil, and tempered at 600° C. and cooled in water	62.5	19.0	43.4	34
Transverse		59.7	8.0	19.6	9

The above test figures go to show that the direction of the grain in the steel has no influence at all upon its tensile strength (yield-point, or elastic limit), but that it has a most profound effect upon the ductility (as expressed by the elongation per cent. and the reduction of area per cent.), and upon the impact or notched bar values. After either treatment the values obtained from samples in which the grain is parallel to the axis of the test piece are very much higher than those obtained when the grain is perpendicular to this axis. Additional information on this point is given by the curves in Fig. 14 (due to Brearley).

## INFLUENCE OF SLAG LINES, ETC., IN RELATION TO THE DIRECTION OF STRESS

MATERIAL BESSEMER STEEL  
CARBON 23. MANG. 07. NICKEL 3 08.

TREATMENT—OIL HARDEN 830°C. AND  
WATER QUENCH 850°C.

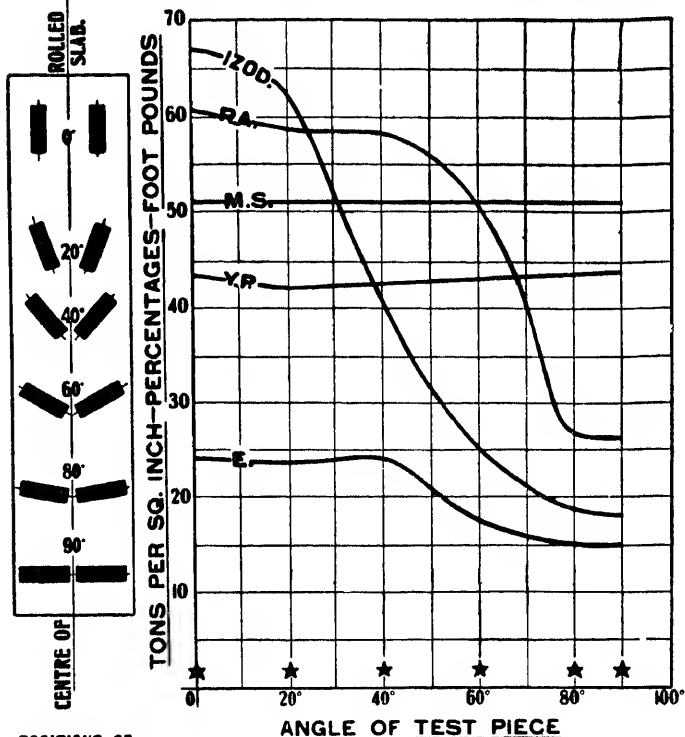

FIG. 14.—(BREARLEY) CURVES SHOWING THE RELATIONSHIP BETWEEN THE MECHANICAL PROPERTIES OF THE STEEL AND THE ANGLE OF INCLINATION OF THE FIBRES OF THE STEEL TO THE AXIS OF THE TEST PIECE.

The net result of this fact to the engineer is that it is always advisable (not to say essential) that the steel in a forging should be so arranged that if the forging is to fracture in use, then the fracture must go *through* all the fibres, and not slide in *between* them. Stated in another way, the fibres of the steel should always be placed at right angles to the principal shear or bending stresses in the part, and parallel to the tension stresses. The good and bad arrangement of the fibres in the steel of a forging can be seen very well in Figs. 15 and 16, which display the right and the wrong ways of arranging the fibres in a crankshaft.

So far, the influence of the ingot structure upon that of the parts forged from it has been confined to the good features, or rather to the general features. No mention has been made as yet of the influence of the defects in the ingot structure upon the forging. The first part of the ingot likely to produce defects, which should be considered, is the outside skin. It has been shown that this outer layer frequently contains fairly large non-metallic inclusions, such as pockets of slag, sulphides, dirt, etc. During forging, these inclusions may be drawn out into threads if they do not lie very near to the surface, or it may happen that, during forging, the steel skin over the inclusions is burst, and a seam or roak is formed, which is elongated, and may run along the surface of a considerable length of the forged part (Fig. 17). It may happen also that, owing to the scaling of the outer skin of the ingot during re-heating for forging, etc., the inclusions may fall right out if they are near enough to the surface of the steel. The development of the drawn-out inclusions into flaws in the finished forgings, may be prevented by the removal (by rough machining) of the outside skin of the steel. Occasionally, the elongated flaws are definitely dangerous, and lead to other flaws in the forgings or machined parts during the operation of heat treatment, particularly during case hardening and the subsequent quenching.

The next most striking flaw which may develop during forging is the splitting of the ingot along the junctional planes of the sets of columnar crystals. In particular, the diagonal planes described on p. 23, and shown so clearly in Fig. 5, may develop into cracks by opening out under the forging. The ingot, or the forging, consequently splits along one or more of these planes, which suffer from lack of cohesion, produced by the disruptive force of the contracting steel after solidification. Naturally, the other zones of weakness which were enumerated may develop into cracks in the same way, though the extent of this development is not so obvious unless the plane or zone of weakness extends right out to the skin of the ingot. Although they are not so obvious, it is fairly certain that in many cases these cracks do exist, and they are often discovered when the forging is machined.

A similar result is produced in the forged steel by the contraction cavities which occur in between the columnar and the free crystals. These cavities have been shown to be intimately connected with the comparatively high proportion of non-metallic impurities which occur in the zone of junction of dissimilar crystals. It can be assumed with certainty that these flaws never extend to the outside of the ingot, or, in the ordinary way, to the outside of the forging. If they are found on the skin, it is because they have spread and increased very greatly during the forging process, far beyond their original limits of size and influence. The defects, if they are discovered at all, are generally found during the machining of the forging. "Hair lines," or "hair cracks," can usually be traced back to this kind of defect in the original ingot. It is a very rare thing indeed for a forging to be spoiled by obvious cracking, or seaming, as a result of the contraction cavities in this particular zone.

The remaining portion of the ingot, which is prone to the development of contraction cavities, is the series of inverted conical zones, which are more or less high in such non-metallic impurities as are found in the ingot.

These zones may give rise to cracks, though it is not very likely that they will do so, as they are much more likely to produce "ghosts" and seams in the finished forging or bar. They may also lead to hair cracks, but will more probably result in a streak of sulphide or slag, or a "ghost," than any other form of trouble (see Fig. 18). This statement must, of course, be qualified a little, because it is obvious that the extent of the "segregation," which is the term applied to cover the unequal distribution of one or more constituents of the steel, will determine the degree to which it will affect the ingot and the forgings made from it. If the highly impure zones in the ingot are of such a size that they become veritable pockets of sulphide and slag, then the effect upon the bars or forgings made from it will be very much greater than if the zones are comparatively small.

The subject of these internal zones or pockets high in impurities naturally leads to that of the effect of pipe upon the ingot and its resultant forgings and bars. It may be said at once that pipe—real unadulterated pipe—should never appear in any product later than the ingot. Its formation at some place in the ingot is quite inevitable, and the only thing which can be done is to cut off that part of the ingot in which it occurs. That the removal of pipe, in some cases, requires the cropping and scrapping of a good deal of the ingot, can be seen from the section of an ingot shown in Fig. 9. A further difficulty encountered in the removal of the pipe is shown in Fig. 19. This section shows a different form of pipe, known as intermittent pipe, which is really a series of pockets running along the axis of the ingot. With an ingot containing such a defect, it is easy to crop down to a certain level in the belief that the pipe ends there, and has therefore been completely cut away, and to forge all the remainder of the ingot. Such a proceeding might result in the incorporation within the forging of a good deal of the pipe. A marked intermittent pipe does not occur frequently, but a somewhat similar result is often

found in an ingot in which the main pipe has really finished above the cropping line, but in which there is a series of tiny pockets along the axis of the ingot. These pockets have been produced in a manner somewhat similar to that which created the inverted cones of segregated impurities previously described. Arising from these pockets and the contraction cavities formed in a similar manner, the resulting forgings and bars may contain a series of capillary holes—intermittent in nature and varying in size—running along the axis of the forging or the rolled bar. Such defects are comparatively common in steel bars.

In connection with the creation of pipe, it was pointed out that one reason why it is formed is because the middle of the ingot is fluid for a longer time than the outside. This means, in general, that the interior portions of the ingot will contain a higher proportion of impurities than the outside, because the melting-point of the impure residue is usually a good deal lower than that of the solid steel from which it is rejected. This statement applies particularly to the sulphides of iron and manganese, which represent the usual forms in which the sulphur is present in the steel. The phosphorus in the ingot is usually found in abnormally high proportions in the same parts of the ingot as contain the high sulphur contents. This means that both the sulphur and phosphorus in an ingot are most plentiful in the metal which was fluid longest. This is shown to be true, in so far as sulphur is concerned, by the sulphur print reproduced in Fig. 20, which represents the longitudinal section of an ingot, and includes the region of the pipe. The presence of the high sulphur round about the pipe has nothing to do with the shape of the pipe or really with the pipe itself, but merely with the fact that the metal which lines the pipe was the last part of the ingot to freeze. Conversely, it might be reasonable to expect all parts of the ingot formed from metal which was fluid for a distinctly longer time than the metal immediately surrounding it, to be high in impurities.

This leads to the conclusion that there will be high sulphur in all the smaller pockets below the pipe, in the conical contraction cavities, etc. Naturally, the segregation of sulphur or phosphorus, or both, is detrimental to the steel products forged or rolled from the ingot. The appearance and distribution of the impurities in the segregated parts of the ingot which has been forged or rolled out into bars can be seen plainly from the sulphur prints in Figs. 21 and 22. It is more than probable that the majority of the cases of failure attributed to high sulphur and phosphorus are not due merely to the average high sulphur and phosphorus but to the fact that, in consequence of segregation, the already high sulphur content is increased to a still higher proportion in some parts, so that the actual content at the position which failed may really be very high indeed. If there had been no segregation, it is possible that the proportion of sulphur in the steel evenly distributed would have been reasonable and harmless throughout the forging.

## CHAPTER III

### THE HEAT TREATMENT OF STEEL

THE heat treatment of steel in some form or other has been carried out for a very long time. It is impossible to imagine the production of such glorious specimens of the cutler's art as are found in the Damascus blades without assuming on the part of the craftsman a keen appreciation of the hardening and tempering of steel. It has been known for almost as long as steel has been known, that, by plunging a red-hot piece of steel into water, the steel may be hardened. The history of the Sheffield cutlery trade makes it equally clear that heat treatment has been known to the English exponents of the cutler's art from time immemorial, and there is little reason to doubt that Chaucer's "Scheffeld thwitel" was hardened and tempered in much the same way as the modern carving-knife, as produced by the average Sheffield cutler of the present day, is hardened and tempered. Up to a relatively recent date, however, heat treatment was carried out upon a very restricted number of steels, the objects of the operation being more or less strictly confined to the production of a good cutting edge, either on cutlery or on turning tools. It is only within the last few decades that serious attempts have been made to utilise the heat treatment of steel as a means of improving its general mechanical properties, so that the steel so treated can be utilised in engineering structures. This is the application of heat treatment which is of interest to the engineer, and, consequently, it will be the effect



of heat treatment upon the mechanical properties of steel which will mainly be considered in this chapter.

It may be well to consider at the start some definition of heat treatment as applied to steel. Heat treatment has for its object the production in a steel of such mechanical properties as are not possessed by that steel in its normal condition, and is carried out by heating the steel to suitable temperatures and cooling it in specific ways. This definition is a fairly wide one, and is particularly vague. It will be seen that it is quite easy to include in this definition all such operations as involve the heating of the steel to any temperature above the temperature of a room, and allowing it to cool at any particular rate. The treatment is not confined to one heating, or to any particular method of cooling. Bearing this in mind, it is evident that a good deal of ground has to be covered in the consideration of heat treatment. It may be well to make the definition more precise by saying at once that under the term, "heat treatment," only those operations are to be considered which do not involve the application of mechanical work to the material, so that forging, drop forging, rolling, and casting are not taken into account. Strictly speaking, these operations are heat treatments, but lengthy usage has sanctioned the restricted application of the term, heat treatment, to operations other than those falling into these categories, and the heat treatment is usually performed after such processes have been completed. The various operations of case hardening, although they are "heat treatments," are also not to be considered in this chapter, since they are dealt with in the chapter on case-hardening steels. The concern of this chapter is therefore with the following operations :—

- (1) Normalising and refining.
- (2) Annealing.
- (3) Hardening.
- (4) Tempering.
- (5) Softening.

In order to crystallise the subject as far as possible, the following definitions of these five operations (as adopted by the British Engineering Standards Association) may be quoted, as they give a reasonable idea of the nature of the processes under consideration.

(1) **Normalising.**—Normalising means heating a steel (however previously treated) to a temperature exceeding its upper critical range, and allowing it to cool freely in the air. It is desirable that the temperature of the steel shall be maintained for about fifteen minutes, and shall not exceed the upper limit of the critical range by more than 50° C. (90° F.).

(2) **Annealing.**—Annealing means re-heating, followed by slow cooling. Its purposes may be:—

(a) To remove internal stresses, or to induce softness, in which cases the maximum temperature may be arbitrarily chosen.

(b) To refine the crystalline structure in addition to the above (a), in which case the temperature used must exceed the upper critical range as in normalising.

(3) **Hardening.**—Hardening means heating a steel to its normalising temperature, and cooling more or less rapidly in a suitable medium, e.g., water, oil, or air.

(4) **Tempering.**—Tempering means heating a steel (however previously hardened) to a temperature below its carbon change-point, with the object of reducing the hardness or increasing the toughness to a greater or less degree.

(5) **Softening.**—Softening is to facilitate the machining of a steel, and is carried out by annealing or tempering, or both.

#### WHY HEAT TREATMENT IS POSSIBLE.

The heat treatments which are of real value in the production of improved physical properties depend upon the fact that in some way or other steel can be rendered hard. It is well known that steel can only be rendered

hard if it be heated to a sufficiently high temperature and be cooled sufficiently quickly. The first two questions in connection with heat treatment which require an answer are therefore: (1) Why is it necessary to heat steel above a certain temperature in order that it may be hardened? and (2) Why must the steel be cooled rapidly? In order to make the answers to these questions sufficiently clear, it will be well to consider first of all the plain carbon steels, that is, steels free from such elements as nickel, chromium, tungsten, etc.

To help in answering the above questions quite simply, it may be advantageous as a preliminary to consider some other substances than steel, which can be visualised more readily. A very instructive substance to use for demonstration purposes is a solution of salt and water. The heat treatment operations to be carried out in connection with the solution of salt and water are quite simple. It is proposed that a quantity of pure water is taken, and that to this pure water consecutive additions are made of a known quantity of common salt. Suitable consecutive additions will be 2 per cent. The subsequent observations will therefore be made upon a series of solutions containing 0, 2, 4, 6, 8, etc., per cent., respectively, of common salt. These solutions are then to be cooled from, say,  $10^{\circ}\text{C}$ . by means of a freezing mixture, and observations made as to what happens during the cooling. The first solution, which contains no common salt at all, undergoes a perfectly simple change, namely, it freezes completely at a temperature of  $0^{\circ}\text{C}$ .

The second solution, if cooled in exactly the same way as the first, does not freeze at  $0^{\circ}\text{C}$ ., but must be cooled to a lower temperature if any freezing is to take place. The 2 per cent. solution will have to be cooled to a temperature of  $-2^{\circ}\text{C}$ . before any separation of solid takes place. When that temperature is reached, a partial freezing of the solution will occur, or, in other words, a certain quantity of solid matter will be deposited from the solution. This solid matter can be strained away, and, if

examined, is found to be pure ice. This shows that only the water in the solution has frozen out, the salt remaining dissolved in the residual liquid. As the temperature of the solution is lowered, more and more solid will separate, but the solid which is deposited is always pure ice. None of the salt comes out of the solution. This process of separation of solid goes on continuously until nearly the whole of the solution has become solid in consequence of the separation of ice. When the temperature of the solution has been lowered very nearly to  $-22^{\circ}\text{C}$ . it is found that almost the whole of the solution has separated in the form of ice, and that only about 8 per cent. of the original solution is left in the liquid form. If this remaining liquid is analysed, it is found to contain about 24 per cent. of common salt. When the solution is cooled finally to exactly  $-22^{\circ}\text{C}$ . the whole of the remaining solution solidifies suddenly, and no liquid whatever remains.

The 4 per cent. solution can now be considered. When this solution is cooled it must be taken to a temperature distinctly lower than that required for the 2 per cent. solution before any separation of ice takes place. From the 4 per cent. solution the first separation of ice does not take place until the temperature has been lowered to  $-4^{\circ}\text{C}$ . As in the case of the 2 per cent. solution, further cooling results in the continuous separation of ice. Once again it is found that, on reaching a temperature of nearly  $-22^{\circ}\text{C}$ ., a certain quantity of solution remains, mixed with a good deal of ice. The amount of residual solution is twice as great from the 4 per cent. solution as remained from the 2 per cent. solution, but if it is separated and analysed it will be found that it contains 24 per cent. of common salt, just as did the residual fluid from the 2 per cent. solution. The residual fluid from the 4 per cent. solution also freezes as a whole when cooled to exactly  $-22^{\circ}\text{C}$ ., at which temperature the whole of the original solution has solidified. Similar observations can be made upon each of the various solu-

tions of common salt, and it is found that, as the percentage of salt in the solution increases, so the temperature at which the first separation of ice occurs becomes lower and lower, but that in every case a certain quantity of solution is left which finally freezes at a definite temperature, this temperature being the same for all strengths of solution. It is also found that this residual solution

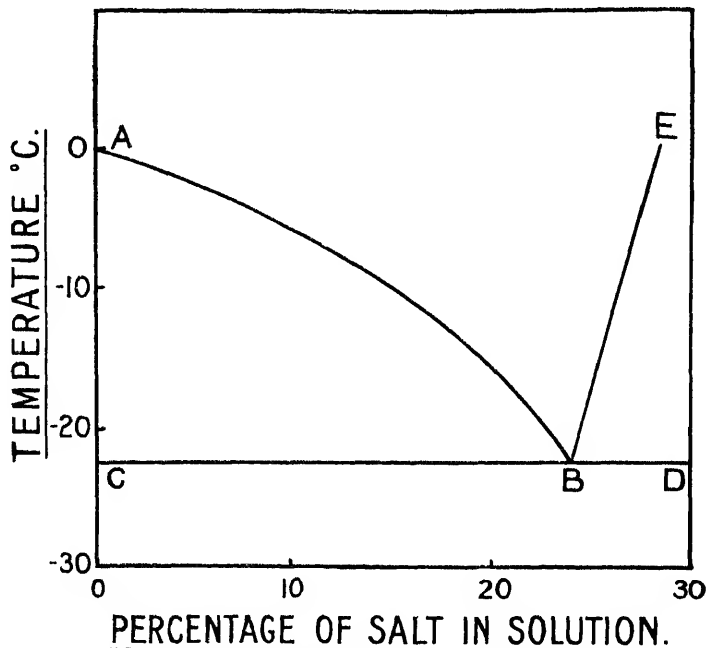

FIG. 23.—THERMAL EQUILIBRIUM DIAGRAM OF WATER-SALT SYSTEM.

always has the same composition, namely, 24 per cent. of common salt, whatever may have been the composition of the original solution which was examined. If a solution containing 24 per cent. of common salt is made up, and its cooling processes examined, it is found that there is no separation of ice during its cooling, and that this solution freezes quite suddenly as a whole at  $-22^{\circ}\text{C}$ .

The observations made upon the various salt solutions can be set out conveniently in the form of a diagram (Fig. 23). On this diagram have been plotted the temperatures at which the first separation of ice takes place during the cooling of the solutions, and also the temperature at which the final solidification of each solution occurs. The diagram makes it plain that the temperatures at which the first separation of ice occurs all lie upon the approximately straight line AB, running from  $0^{\circ}$  C. (for the pure water) to  $-22^{\circ}$  C. (for the 24 per cent. salt solution), whilst the temperature at which the whole solution becomes solid is  $-22^{\circ}$  C. in every case. The final solidification, therefore, of all the salt solutions is represented by the straight line CD, which runs parallel to the axis of composition.

After considering such a homely material as common salt, a similar series of observations can be carried out on a mixture of metals. A very convenient mixture of metals to consider is lead and tin. Observations can be made upon such a mixture by taking a certain quantity of pure lead and measuring, with a pyrometer, the temperature at which it freezes. Successive additions of 5 per cent. of tin can then be made to the pure lead, and observations again made of the temperatures at which freezing commences and finishes. Just as the solution of common salt deposited first pure ice, and then, at a definite temperature, became completely solid by the separation of a definite mixture of salt and ice, so the lead-tin mixture deposits first of all pure lead, and then at a certain definite temperature ( $180^{\circ}$  C.) becomes completely solid by the deposition of a definite mixture containing 63 per cent. of tin and 37 per cent. of lead. The series of observations made on the lead-tin mixtures can be plotted in the same way as were the observations made on the salt solutions, and the resulting diagram is shown in Fig. 24. It can be seen in the mixtures of lead and tin that, once again, the temperature of final solidification, as represented by the line DE, is the same for all the

mixtures, and it can also be seen that the composition of the substance which finally solidifies is always the same, namely, 63 per cent. of tin and 37 per cent. of lead.

It will help the consideration of the problems arising in connection with steel considerably, if yet another set of observations is made upon the lead-tin mixtures. These observations consist in noticing the rates of cooling of all the mixtures when they are cooled from the com-

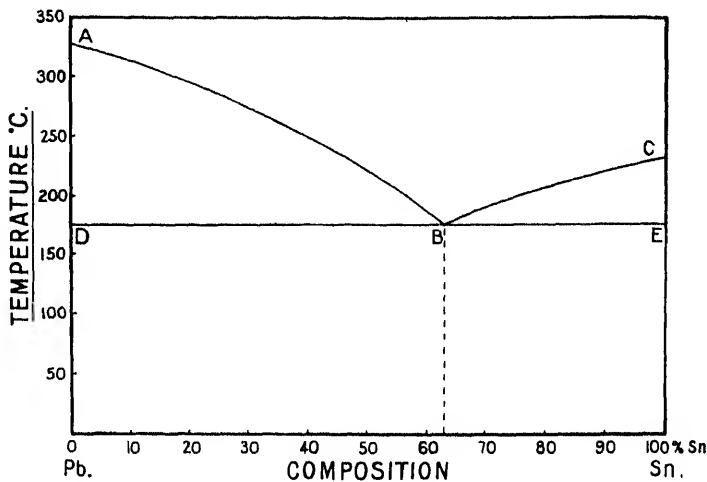

FIG. 24.—THERMAL EQUILIBRIUM DIAGRAM OF LEAD-TIN SYSTEM.

pletely liquid to the completely solid condition. An easy way of observing what happens is to insert a pyrometer in the cooling liquid, and to notice the number of seconds which are required to cause the mixture to cool through each successive  $1^{\circ}$  C. These numerous observations can then be plotted upon a curve. A typical curve of such observations is shown in Fig. 25. This curve is not a smooth one, that is to say, the number of seconds required to cool  $1^{\circ}$  C. is not always the same, and at two different temperatures the rate of cooling has been very

considerably lessened. It is found, also, that the two temperatures at which the rate of cooling is retarded, correspond to quite definite events in the cooling of the mixture. The upper retardation of cooling takes place when the first separation of lead (or tin) occurs, and the second retardation takes place at the temperature which marks the final solidification of the mixture. The retardation in the rate of cooling is due to the fact that the separation of solid from the solution is accompanied by the evolution of heat. This heat is latent, and its

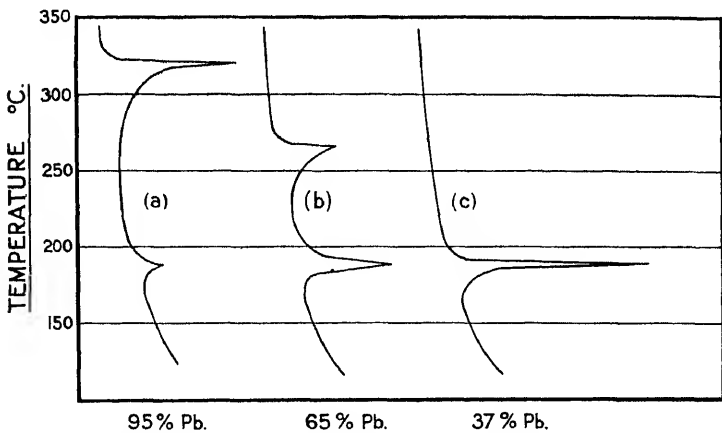

FIG. 25.—INVERSE RATE COOLING CURVES OF DIFFERENT MIXTURES OF LEAD AND TIN.

evolution corresponds with that which occurs when steam liquefies or water freezes.

The second retardation takes place at the same temperature over the whole range of composition of the lead-tin mixtures, but the upper retardation takes place at a temperature which depends upon the composition of the mixture. This temperature has already been shown to be represented by the upper line ABC in Fig. 24.

By these two series of simple experiments certain definite



facts have been established. Those which are of importance in connection with the study of steel are :—

(1) The temperature at which a solution begins to deposit solid is dependent upon the composition of the solution. In general, it is found that the temperature at which the deposition of solid commences is lower in strong solutions than in weak solutions.

(2) A solution does not usually become completely solid at one temperature, but does so over a range of temperature starting at a temperature which varies according to the composition of the solution, and in many solutions finishing at the same fixed temperature, whatever the composition of the solution may be.

(3) The temperature of the final solidification of a solution is a function of the constituents of the solution, i.e., lead and tin, or salt and water, and not of the particular composition of the solution.

(4) That the deposition of solid from a solution is always accompanied by a retardation in the rate of cooling of that solution.

These four points having been established, the discussion of steel can be resumed. In this connection the fourth point calls for first consideration. It has been shown that when the separation of any substance from a solution occurs, there is a retardation in the rate of cooling of that solution. It is reasonable, therefore, to assume the converse, namely, that if a retardation in the rate of cooling be found when the cooling of a solution is observed, then this retardation corresponds to the separation of something or other from the solution. Bearing in mind this reasonable assumption, some curves showing the rates of cooling of plain carbon steels can be considered. In Fig. 26 are shown four cooling curves of steels, containing, respectively, nil, 0.3, 0.6, and 0.9 per cent. of carbon. It is evident that these curves have a very

close resemblance to the curves shown in Fig. 25, which represents the cooling of lead-tin mixtures. In the steel curves the final retardation occurs at the same temperature, namely,  $695^{\circ}\text{C}$ . in all the four steels, this temperature presumably corresponding, therefore, to that of  $180^{\circ}\text{C}$ . for the lead-tin alloys. It is fairly reasonable to assume, consequently, that the retardation has the same significance for the steels as for the lead-tin alloys, and, therefore, to state that in plain carbon steels there is always a final separation of something or other from solution at  $695^{\circ}\text{C}$ . The upper retardation occurs at

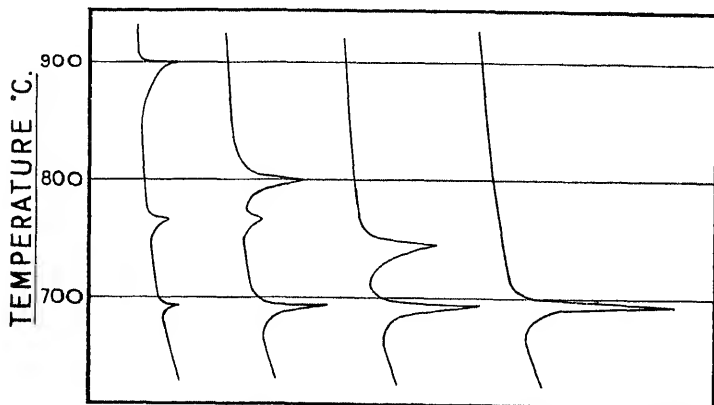

FIG. 26.—INVERSE RATE COOLING CURVES OF FOUR STEELS.

different temperatures in the three steels. With the 0.3 per cent. carbon steel the retardation occurs at about  $810^{\circ}\text{C}$ ., and with the 0.6 per cent. carbon steel at about  $740^{\circ}\text{C}$ . The steel, i.e., pure iron, containing no carbon has its retardation at about  $900^{\circ}\text{C}$ . With the 0.9 per cent. carbon steel there is only one retardation, namely, at  $695^{\circ}\text{C}$ ., and bearing in mind what happened with the common salt solution and with the lead-tin alloys, it appears reasonable to assume that the final substance which separates from solution at  $695^{\circ}\text{C}$ . from all the plain carbon steels contains 0.9 per cent. of carbon.

The diagram in Fig. 27 shows the temperatures of retardation for steels containing any percentage of carbon from 0 to 1.2 per cent., the upper line corresponding to the first separation of solid from the solution, and the lower line corresponding to the complete final separation from the solution. It has already been shown that the substance which finally separates from solution contains 0.9 per cent. of carbon (thus corresponding to the

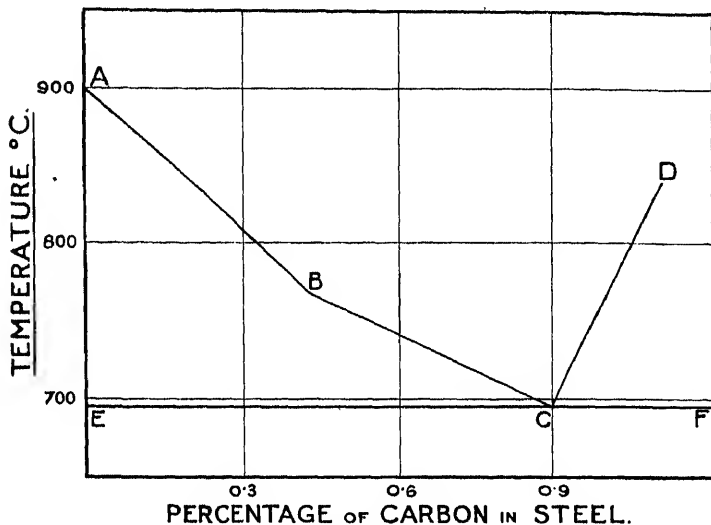

FIG. 27.—THERMAL EQUILIBRIUM DIAGRAM (LOW TEMPERATURE PORTION) OF IRON-CARBON SYSTEM.

mixture containing 63 per cent. of tin and 37 per cent. of lead in the lead-tin mixtures, or to the mixture containing 24 per cent. of common salt in the common salt solution). In the common salt solution it was found that the substance which first separated was pure ice, in the lead-tin mixtures it was found that the substance which first separated was pure lead, therefore it is safe to assume that in the iron-carbon mixtures containing less than 0.9 per cent. of carbon the substance

which first separates from solution will be pure iron. If the steel contains more than 0.9 per cent. of carbon the substance which separates at the upper retardation temperature is obviously not iron. It might be expected from the analogous case of lead and tin that it would be carbon, since the important constituents of steel are iron and carbon. This assumption is only partially correct. The carbon does separate, but not in the form of the element carbon. The separated substance is iron carbide, i.e., a compound of iron and carbon. This fact shows that the critical constituents of steel are not iron and carbon, but iron and iron carbide. The mixture, therefore, which separates at  $695^{\circ}\text{C}$ . is not a mixture of iron and carbon, but a mixture of iron and iron carbide. The mixture contains 0.9 per cent. of carbon, but 13.5 per cent. of iron carbide.

In this discussion of the changes which take place when steel is cooled, various statements have been made regarding substances which separate from "solution." That this is justifiable is seen by the close analogy which steel bears to the well-known solution of salt in water. With steel, however, the solution is not exactly such as is usually imagined, e.g., salt in water or grease in petrol. It is a kind of solution which has very similar properties, but which, instead of being liquid, is solid. The solution from which the pure iron separates as shown in Fig. 27, is not a *liquid*, but is a *solid* solution. (This will be obvious from a consideration of the temperatures under discussion, all of them being below  $950^{\circ}\text{C}$ ., whilst the melting range of steel is round about  $1,400^{\circ}\text{C}$ .)

It is possible now to proceed to answer more definitely the two plain questions which were put at the beginning of this chapter, as to why steel can be hardened. Consider the cooling of a piece of steel containing 0.3 per cent. of carbon, from a temperature of  $900^{\circ}\text{C}$ . It is evident, from what has been said, that at a temperature of  $900^{\circ}\text{C}$ . this steel will consist completely of solid solution. As it cools, nothing will happen until the

temperature reaches that corresponding to the first retardation of cooling (called the upper critical point), which in this steel will be about  $810^{\circ}\text{C}$ . At this temperature a certain quantity of pure iron will separate from the solution (see Fig. 27). The separation of additional pure iron will continue during the further cooling, until the steel reaches a temperature of about  $695^{\circ}\text{C}$ ., at which temperature there will be a final and complete separation of the definite mixture of iron and iron carbide, containing 0.9 per cent. of carbon. This is the micro-constituent known as pearlite (see Fig. 28). Lowering the temperature below  $695^{\circ}\text{C}$ . results in no further change of structure in the steel. The final structure produced by cooling to ordinary room temperatures is shown in Fig. 29, which displays the micro-structure of the steel after it has cooled in the way which has been described. Two constituents are present, one of them white, and the other grey. The grey is the material containing 0.9 per cent. of carbon, i.e., the pearlite, and the white constituent is pure iron.

The micro-structure photographed in Fig. 29 shows clearly that the amount of pure iron in the steel is very large. The properties of pure iron are quite well known, and one of these properties is extreme softness. It is evident, therefore, that if the steel is going to be hard it must be given a structure which is as free as possible from separated iron. The only way to prevent the occurrence of separated iron in a steel, is to cool it in such a way that the iron cannot come out of solution. The separation of a substance from solution, and particularly from a solid solution, necessarily takes a certain amount of time. No action can be absolutely instantaneous, and, therefore, if the time of cooling be reduced very considerably, it is possible that the amount of iron which separates from the solution can be lessened simply because it has not the time to separate. To reduce the time available for the separation of iron, it is evident that the cooling must be carried out as rapidly as possible, and, in order to ac-

comply with this, the steel is cooled in a cold liquid, frequently water. By cooling the metal in water the separation of iron can, in a great measure, be avoided, and the steel can be preserved in a condition approximating to that which it possessed at the high temperature, namely, a condition in which all the iron and carbon, etc., are in solution in each other (see Fig. 30). This explanation, then, offers the answer to the second question, namely, "Why must steel be cooled rapidly?"

The answer to the first question, as to why a steel must be heated above a certain temperature if it is to be hardened, is surely quite plain from the above discussion. After the material has cooled below  $695^{\circ}\text{C}$ . the solid solution has been completely decomposed, and, therefore, however rapidly the steel is quenched, it is not possible to retain it in the form of a solution, and consequently it cannot be hardened. It is evident, therefore, that the steel must be heated to a temperature at any rate higher than  $695^{\circ}\text{C}$ . if the solid solution is to be found in the finished steel, that is, if the steel is to be hardened. It is important to note here that a steel would not be hardened if it were heated from ordinary room temperature to a temperature slightly above  $695^{\circ}\text{C}$ . and then quenched. This is due to the fact that the reverse structural change, i.e., the passing again of the pearlite, or the mixture containing 0.9 per cent. of carbon, into solution, does not take place at the same temperature as the direct change of falling out of solution. The transformation into solution takes place at a temperature of about  $740^{\circ}\text{C}$ ., as can be seen from the heating curve of a steel, as shown in Fig. 31. It is necessary, therefore, to heat a steel to a temperature of about  $750^{\circ}\text{C}$ . if it is to be hardened at all, although it is possible to harden it from a temperature rather lower than this if it has previously been heated to a higher temperature, e.g.,  $850^{\circ}\text{C}$ ., and has not subsequently been cooled below  $695^{\circ}\text{C}$ .

If the steel were heated to a temperature of about  $750^{\circ}\text{C}$ . and then quenched, it would contain a certain

amount of solid solution, the exact amount being proportional to the quantity of pearlite which was present in the original steel, this, in turn, being proportional to the amount of carbon in the steel. It has been shown that the hardness of the steel is dependent upon the existence of the solid solution, but it is not reasonable to expect a steel to be very hard if it consists of a small

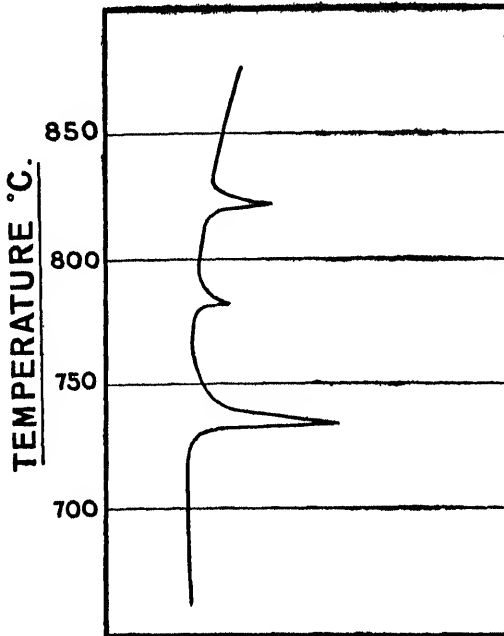

FIG. 31.—INVERSE RATE HEATING CURVE OF STEEL CONTAINING 0.30 PER CENT. OF CARBON.

proportion of solid solution and a large proportion of free iron. The properties of the free iron would tend to overshadow the properties of the smaller proportion of solid solution. In order, therefore, to produce the maximum hardening effect, it is necessary to increase, as far as possible, the proportion of solid solution in the steel. In other words, if the steel is to be hardened

properly and completely, it must be previously heated to such a temperature as converts it completely into solid solution. This means that the temperature of the steel must be raised, before quenching, to such a height that all the free iron has dissolved in the solid solution. This is to say, that the steel must be heated at least to the temperature indicated by the upper critical point.

Most of what has been said above regarding the structural changes in steel, applies to those changes which occur while the steel cools, but the reverse changes in structure produced during heating are exactly similar, although they do not necessarily occur quite at the same temperature during heating as during cooling. The correct hardening temperature, therefore, of a piece of steel is the upper critical temperature, since this is the temperature at which the steel has been transformed completely into the form of one constituent. The diagram in Fig. 27 shows on the line ABCD the temperature at which the upper critical point occurs in the various carbon steels, and therefore shows what is the theoretically correct hardening temperature. For practical purposes, it is customary to quench steels with not more than 0.9 per cent. of carbon from a slightly higher temperature than the theoretical. The steels containing free carbide, i.e., all those with more than 0.9 per cent. of carbon, are usually quenched from the temperature which is suitable for steels containing about 1.0 per cent. of carbon. This temperature is below the theoretical hardening temperature for the steels containing the higher proportions of carbon, and is chosen for strictly practical reasons, which do not affect the theoretical principles in any way (see Chapter IX on "Tool Steels").

The above discussion has given some account of the facts which make it possible for steel to be hardened, and, as stated above, hardening underlies all those various heat treatments which are carried out with the intention of improving the physical properties of steel. It also gives some reasonable explanation of the fact that steels



containing a high proportion of carbon are harder, when quenched, than those with a low proportion of carbon. The solid solution is formed from iron and iron carbide. The iron is soft, but the solution is not. If, therefore, the solution is concentrated, it is likely to be harder than if it is dilute. The concentration of the solid solution depends upon the quantity of carbon in the steel, and hence it would be expected that the higher the carbon the harder would be the steel, when in the complete solid solution condition.

To impress the effect of hardening, a few examples of the changes of mechanical properties which are induced by the operations of hardening may be quoted, the test results showing the properties of carbon steels after they have been cooled in air, oil, and water from different temperatures. It is well known that the rate of cooling in oil is not so high as that of cooling in water, hence the preservation of the solid solution is not so perfect, and consequently it is to be expected that the degree of hardening which has been effected by cooling in oil is not so high. Suitable test results are given in Table 3.

#### THE EFFECT OF ALLOYING ELEMENTS UPON THE HARDENING OF STEELS.

All that has been written above has to do with plain carbon steels. Such steels do not meet all the requirements of the engineer as regards mechanical properties, and are by no means the only steels which are heat treated. It is necessary, therefore, to consider what changes are introduced into the fundamental processes by the addition, to the steel, of certain percentages of such alloying elements as nickel and chromium. It will probably be sufficient to consider only these two elements, both singly and together.

For the nickel steels, it is not so easy to present the facts in a diagrammatic form as for the plain carbon steels, since in a nickel steel there are three possible

variants, namely, iron, nickel, and carbon, which ought to be considered. It is consequently not possible to draw a simple diagram, as was done with the plain carbon steels, in order to show the effect of variations in composition upon the heating and cooling transformations of the steels, and upon the temperatures at which the critical points occur. The only way in which a reasonable

TABLE 3.

THE EFFECT OF DIFFERENT METHODS OF COOLING UPON THE MECHANICAL PROPERTIES OF PLAIN CARBON STEELS.

*Diameter of Specimens at Time of Heat Treatment—1½ inches.*

Carbon, per cent.	Manganese, per cent.	Cooled from, °C.	Method of Cooling.	Max. Stress, tons per sq. in.	Izod Impact, ft.-lb.
0.06	0.25	920	Air	27.0	11
0.06	0.25	920	Oil	28.3	81
0.06	0.25	920	Water	36.3	53
0.15	0.61	880	Air	33	102
0.15	0.61	880	Oil	39	103
0.15	0.61	880	Water	43	95
0.26	0.50	870	Air	34	27
0.26	0.50	870	Oil	40	22
0.26	0.50	870	Water	44	18
0.45	0.78	870	Air	42	31
0.45	0.78	870	Oil	54	31
0.45	0.78	870	Water	65	13

diagram can be obtained, is to ignore the iron altogether, and to plot the curve with the nickel percentage as the basis. This has been done in Fig. 32, and the resulting diagram shows that the effect of the addition of nickel to the steel is to lower considerably the retardation temperatures, i.e., "critical points," as they will be called in future. The amount of nickel required to effect a considerable alteration in the critical temperatures depends upon the carbon content of the steel, but the

diagram shows that by adding about 6 per cent. of nickel to the steel, the lower critical point, which occurs at

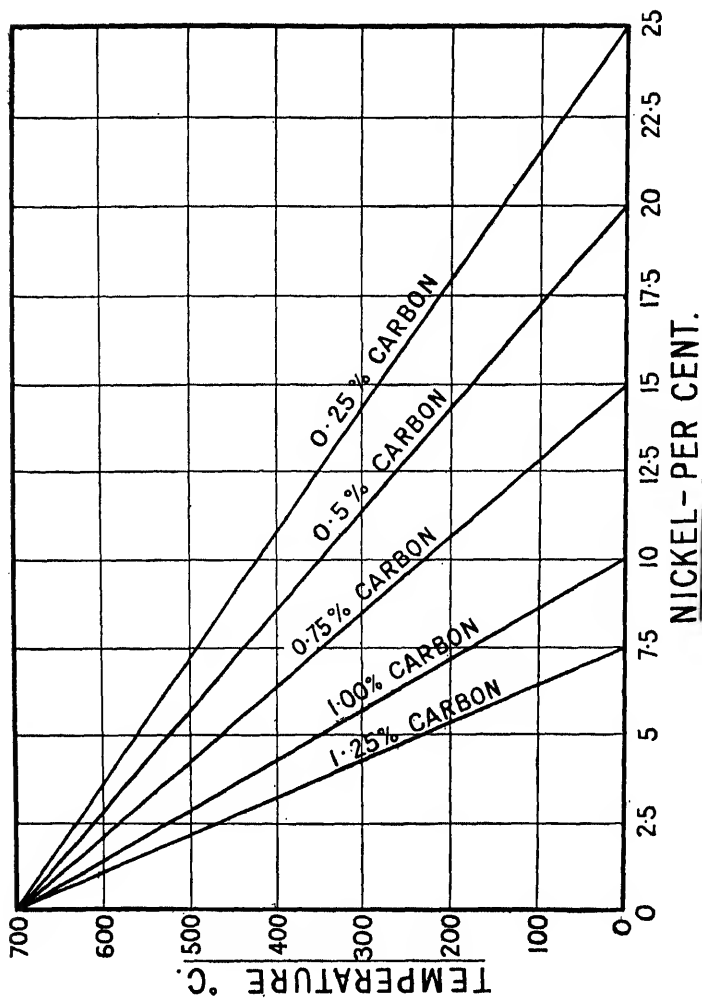

Fig. 32.—DIAGRAMMATIC REPRESENTATION OF THE INFLUENCE OF COMPOSITION UPON THE CRITICAL TEMPERATURES OF NICKEL STEELS.

695° C. in plain carbon steel, can be brought down to 280° C. when the carbon in the steel is as high as

the cooling of a steel containing nickel, the iron can be kept in solution much more easily than when cooling the steels which are free from nickel. In addition to lowering the critical points of the steel, nickel has the effect of making the solid solution formed in the steel at high temperatures more stable, i.e., more persistent, during cooling. This applies equally when the steel is cooled rapidly. Both these effects make a steel containing nickel easier to harden than one free from nickel. Consequently, the quenching of steels containing an appreciable proportion of nickel, need not be carried out in quite such a drastic manner as must be employed for the plain carbon steels. Nickel steel, of a given size, when quenched in oil, may be hardened just as effectively as a steel free from nickel which has been cooled in water. If the percentage of nickel and carbon is sufficiently high, a solid solution is produced in the steel at high temperatures which is so stable, and which decomposes so sluggishly, that it retains its form and nature even after cooling in the air. Such a steel may be as hard, after cooling in the air, as a plain carbon steel is after cooling in water. A steel which behaves in this way is termed "air hardening," or "self hardening," the former title being decidedly preferable.

Although chromium has not, in the past, been widely used by itself as a constituent of alloy structural steels (stainless steel is for the moment neglected in this connection), it is well to appreciate the effect of this element upon the fundamental principles of the hardening of steel. Chromium, when added to steel, raises the temperatures at which the critical points occur, and therefore a chromium steel must be heated to a higher temperature, if it is to be hardened, than is required for either a plain carbon steel or a nickel steel. Taken by itself, this effect of chromium should make it more difficult to harden chromium steels, but it is found that chromium, like nickel, produces in the steel a solid solution of superior

stability or greater viscosity than that found in carbon steels, so that in reality the hardening is not made any more difficult by the addition of chromium (see the account of air-hardening steel in Chapter VI). With low percentages of chromium, the ease of hardening is not appreciably different in chromium steels and in plain carbon steels, but with higher percentages of chromium the hardening is distinctly easier, the solid solution being so stable that, despite the raised critical point, the steel will harden when cooled in air. This effect is especially notable if the chromium content is greater than 7 per cent. and the carbon greater than 0.5 per cent.

The general effect of the addition of alloying elements to steel is to produce a solid solution which is more stable and more viscous, and which, when cooled, does not easily decompose by the deposition of free iron. This effect tends to make the hardening of the alloy steels easier than that of plain carbon steels. At this point it may be well to point out that manganese is an alloying element to just the same extent as nickel and chromium, and that manganese produces a very similar effect upon the steel. In fact, manganese may be considered, in some ways, to have a greater effect than nickel. As all steels contain a greater or less proportion of manganese, it is well to remember this fact, and to appreciate that a steel containing 1 per cent. of manganese is likely to harden much more easily than a steel containing only  $\frac{1}{4}$  per cent. (see p. 144).

Many steels contain both nickel and chromium, and these steels have the properties which might be expected if the separate effects of nickel and of chromium, as described above, are added together. The hardening temperature (critical point) is not very different from that of the plain carbon steels, being generally rather

stable, and far less nickel and chromium, when present together, are required to produce an air-hardening steel than are necessary if the two elements are present separately. To produce an air-hardening nickel steel requires approximately 6 per cent. of nickel, and 1.0 per cent. of carbon. An air-hardening chromium steel may require 7 per cent. of chromium and 0.7 per cent. of carbon, but a steel containing 4.0 per cent. of nickel, 1.3 per cent. of chromium, and only 0.25 per cent. of carbon, with the usual amount of manganese, hardens in air most efficiently (see also p. 174).

### THE TEMPERING OF STEEL.

When a steel, particularly an alloy steel, is completely hardened, it is probably much too hard for the purposes of the engineer, and is also probably much more brittle than he desires. The steel must, therefore, be softened somewhat, i.e., lowered in tensile strength, and, if possible, rendered more tough. These two effects are produced by the operation known as "tempering," which consists of re-heating the steel to a suitable temperature, and allowing it to cool in a suitable manner (cf. the definition on p. 39). It is evident that the highest temperature, permissible in the tempering operation, must not be as high as the lowest temperature from which the steel can be hardened, i.e., the lower critical temperature on heating, as otherwise *all* the effects of hardening would be removed. The object of the tempering operation is not to remove, but to modify the effects of hardening. The maximum tempering temperature of the plain carbon steels must, therefore, be a few degrees below 740° C., say 700° C. (It may be assumed, for the time, that the alloy steels have the same critical temperature on heating as the carbon steels.)

It is desirable to examine what really occurs during the tempering operation, so that the principles underlying it may be understood. The effect of tempering may be observed in several ways, two convenient ones being :

(1) the effect upon the mechanical properties of the steel and (2) the effect upon the structure of the steel. For the sake of simplicity, the plain carbon steels are considered first, and it is assumed that the steel under discussion has been hardened completely in water, the hardening having been successful enough to produce nothing but solid solution in the steel. Such a steel will be very strong but will have poor values of ductility and impact. If this steel is re-heated to various temperatures between room temperature and  $700^{\circ}\text{C.}$ , and then cooled in air, it is found that the maximum stress of the steel decreases more or less continuously as the tempering temperature rises, and, at the same time, the ductility and impact values rise. The effect of the tempering operations upon the mechanical properties can be seen in the curves given in Fig. 59. These test results show clearly the effect of the tempering, but they do not show the cause of it. This is to be looked for in the changes which occur in the structure of the steel during the tempering operation.

Expressed briefly, the structural changes which occur during tempering, consist in the more or less complete decomposition of the solid solution which has been produced by hardening the steel. The natural condition for a carbon steel to assume at ordinary temperatures is not that of a solid solution, but of a mixture of iron and pearlite (see Fig. 29), and the solid solution has only been produced by the very rapid cooling, which has suppressed or prevented those changes of structure which would naturally occur if cooling took place at the normal rate, i.e., when cooling in air. The quenched steel, being an artificial condition, has always a tendency to return to the condition which is natural to it, i.e., the stable condition, and the stable state at ordinary temperatures of carbon steels is one which contains no solid solution. By raising the temperature of the hardened steel, the return of the solid solution to the stable condition is greatly facilitated, and the higher the temperature of the steel, the more easily is the change carried out. Temperi-

A steel is, therefore, ready the changing back of the steel, more or less completely, and to a controllable degree, from the unstable solid solution condition to the condition in which it normally exists, i.e., a mixture of iron and iron carbide, or iron and pearlite. The reversion or decomposition of the solid solution proceeds gradually, and the deposition at an appreciable rate of iron and iron carbide, from solution, starts at a relatively low temperature, e.g., about 200° C., and goes on continuously as the temperature is raised. It is not easy to show this change by means of a series of micro-photographs, but it may be demonstrated by other means.

When a steel consists entirely of solid solution it is not easily attacked by acids or other etching reagents. When it consists of a mixture of iron and pearlite (which in itself is a mixture of iron and iron carbide), as shown in Fig. 28, the free iron is not much attacked by the acids, but the pearlite is attacked vigorously. It is found also, that practically all steels which consist of a mixture of iron and iron carbide are attacked vigorously by acid. One would, therefore, expect that a steel which has been tempered would be attacked by acid more vigorously than a steel which has not been tempered. This is precisely what does happen, and the curve given in Fig. 33 shows the effect of tempering at different temperatures upon the rate at which the steel dissolves in acid. It may be seen that, as the tempering temperature rises, the solubility rapidly increases until it reaches a maximum at 400° C. After passing this temperature, the solubility falls away again. The curve in Fig. 33 may be interpreted as showing, first of all, the gradual decomposition of the solid solution by the falling out of solution of the iron and carbide of iron. The greater the amount of decomposition which has occurred, the more rapidly does the steel dissolve in acids. At 400° C., it may be imagined that the solution has been completely decomposed, thus reducing the maximum degree of solubility in the acid. On tempering at still higher temperatures, the alteration



of structure which occurs, does not take place in the solution (which, since there is no solution left, is obvious), but in the separated iron and carbide of iron. By the decomposition of the solution, these two substances are deposited in a very fine form, and completely disseminated within each other. By heating the mixture to a still

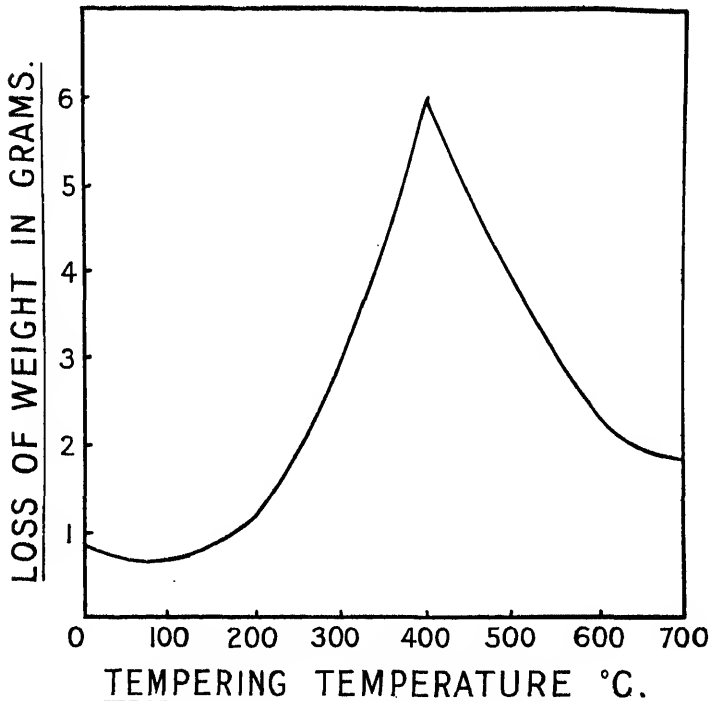

FIG 33.—CURVE SHOWING LOSS OF WEIGHT IN ACID OF SAMPLES OF HARDENED STEEL TEMPERED AT DIFFERENT TEMPERATURES.

higher temperature than 400° C., these two constituents begin to segregate, the very fine particles of carbide probably coalescing into larger ones. This change in the structure of the steel should have the effect (which is generally observed) of reducing the solubility of the metal in the acids, and therefore the solubility in acids

will diminish as the tempering temperature rises from 400° C. to 700° C. The final condition of the steel, after tempering at a temperature just below 700° C., is that of an intimate mixture of very fine, but distinct, particles of iron carbide with the iron. The particles of carbide are distinctly smaller than would be found in a steel which had never been hardened (Fig. 34). (This theoretical explanation gives a good working idea of what is taking place in the steels. It does not pretend to account for all that happens during the tempering operation, and gives no explanation of some of the more obscure changes which are reflected in the alterations in the mechanical properties of the steels.)

In the alloy steels the process of tempering has a very similar effect, although in these steels it is rare to reach the stage at which a mixture of iron and segregated iron carbide is produced, particularly in the nickel chromium steels. The structural and mechanical changes, however, are essentially the same in the alloy and in the plain carbon steels, and, therefore, there is no need to discuss the alloy steels separately.

#### THE NORMALISING OF STEEL.

The previous sections have had for their subject the consideration of those principles which underlie the production of special mechanical properties in steels. There are certain other functions of heat treatment which should be considered, the aims of which are not so obviously to change the mechanical properties of the steel, as to improve its quality, i.e., to remove certain defects which are not easily represented by the usual tests for the mechanical properties. The best known operation of this kind is normalising. The primary object of this process is to give a steel its "normal" structure, as might be imagined from its title (cf. the definition on p. 39).

Steel which has gone through such various operations as rolling, forging, drop forging, or casting, is not usually in its normal condition, after the completion of these

processes, even though they have been carried out in the best and most efficient manner. In a casting, the steel has been allowed to cool from a high temperature without receiving any mechanical work during the process. In forging, rolling, or drop forging the temperature from which the steel cools is not so high, reckoning the temperature from which the steel cools as the temperature at which the mechanical working ceased, as in a casting, but the steel has received a good deal of distortion and punishment, and may, therefore, reasonably be considered to be in a strained condition. Even after mechanical working, the steel sometimes cools down from a fairly high temperature. In case hardening also, the steel is heated to a relatively high temperature for a prolonged period, and therefore is in the condition (approximately) of a casting. After any of these treatments, the steel may be considered to have cooled down from a fairly high temperature, and to possess all the defects which are produced in steel which has suffered such exposure. The effect of heating a steel to a high temperature, i.e., a temperature distinctly above the line ABCD in Fig. 27, is to produce in it a structure which is distinctly coarse. It was explained on pp. 47 to 49 that at temperatures higher than those indicated by the line ABCD in Fig. 27, the steel consists entirely of solid solution. This solid solution really consists of an agglomeration of crystals. When the temperature rises, these crystals grow larger and more geometrical in external form (see Fig. 35). Consequently a steel which has been heated to a high temperature, and allowed to cool without being worked, consists of a collection of large, coarse, fairly geometric crystals. This is not a good condition, as the best steel has a "fine grain," i.e., is composed of small crystals. One object of normalising is to assist in the production of this desirable fine grain in the steel.

It is not necessary to go through all that happens to a steel during heating up from room temperature to a very high one, but it may be well to recapitulate a little

in order to ensure that the significance of normalising is thoroughly understood. At the ordinary temperature of the air the steel consists of a mixture of two constituents, iron and pearlite (speaking only of plain carbon steel). When this mixture is heated to the temperature of the lower critical change-point, the pearlite transforms into solid solution. On further heating, this solid solution dissolves in the excess of iron which is present, until at the upper critical temperature (see Fig. 27) the steel consists entirely of solid solution. The upper critical temperature is, therefore, the lowest temperature at which the steel consists of one homogeneous constituent, and at this temperature also the grains or crystals of the solid solution have their smallest size (Fig. 36). If the steel is heated to a higher temperature than the upper critical temperature, these grains or crystals grow larger and more geometric in external form. At the critical temperature they are of the smallest size, and least geometric in form.

The size of the crystals, found in the steel after cooling, is practically decided by the size of the crystals which exist in the steel at the time that it cools through the upper critical temperature. All engineers desire that their steel shall have a "fine grain," i.e., small crystals, and, therefore, it is necessary that the steel shall have small crystals at the time that it cools through the critical temperature. This means that the temperature to which it was heated, prior to the final cooling, must not have been much higher than the upper critical temperature. Hence the reason for the insertion in the definition of the process of normalising, of a statement that the temperature employed should not be more than  $50^{\circ}\text{C}$ . higher than the upper critical temperature. The theoretically correct temperature of normalising is the upper critical point. Practical considerations require a little latitude.

The operation of normalising is one of complete regeneration. When it is carried out, the effects of all

the previous treatments of the steel are wiped away. The operations of hardening and tempering, of cold working, of annealing, of casting, etc., are eliminated, in so far as their structural effects are concerned, from the steel. If the steel, before normalising, possesses a large coarse structure, the operation of normalising will remove it and replace it with the finest one possible. Whatever the previous treatment given to the steel may be, short of partial melting, its effects may be wiped out by heating the metal to the normalising temperature, and cooling it in the air.

In addition to the direct structural effect upon the steel, the operation of normalising has the further effect of removing from the steel those mechanical strains which have been locked up within it by such processes as rolling, or drop forging, or cold working. All these operations are bound to strain the steel in some way or other, and the operation of normalising is necessary in order to remove these strains, which might be dangerous in a finished part. Normalising effects the removal, by allowing the steel to cool freely through the critical ranges under such conditions as impose no strain upon the metal.

#### ANNEALING.

The process of normalising is often confused with that of annealing. The titles of the two processes are frequently muddled, with most unfortunate results. The process of annealing has some of the same objects as that of normalising, but it is carried out differently. A reference to the definition of normalising shows at once that in this process the steel is merely heated throughout to the appropriate temperature, and then is cooled down in the air so that the changes of structure which

required temperature, and retained at that temperature for a long time, varying from a few hours to several days. In general, so far as structural steels are concerned, the protracted heating serves no good purpose. The cooling process also is allowed to extend over a protracted period, since the steel is left in the furnace until both steel and furnace have reached atmospheric temperature.

A lengthy stay at the high temperature allows the steel to undergo a complete re-crystallisation. The temperature used for annealing is often (particularly for castings) rather higher than that used for normalising, and consequently there is ample scope for the formation of quite large crystals. Nothing occurs during the cooling to cause the breaking up of these large crystals. Moreover, during the cooling, which is frequently very slow, the time taken by the steel to pass through the range of temperature, between the upper and lower critical points, allows the changes of structure incidental to the cooling of steel to take place to the fullest and most complete extent. This results in the very complete separation of the iron from the pearlite into distinct and large masses, and also allows the pearlite to separate out into its constituents with singular completeness and perfection of form. The final structure can be seen, from a typical photograph, in Fig. 37.

The mechanical effect of annealing is what might be imagined from the nature of the structure which it produces. The carbon steels are most usually submitted to the annealing process, and in them the result is, as stated above, to throw out the iron into large crystals of irregular shape. There is no mixing of the constituents. The steel, therefore, is very definitely soft and ductile, though not particularly tough. Some typical test figures, illustrating the effect of annealing as compared with that of normalising upon the properties of steel, are given in Table 4.

TABLE 4.

THE EFFECT OF NORMALISING AND ANNEALING UPON THE MECHANICAL PROPERTIES OF DIFFERENT CARBON STEELS WITH VERY LOW MANGANESE.

Carbon, per cent.	Heat Treatment.	Yield-point, tons per sq. in.	Max. Stress, tons per sq. in.	Elongation, %.	Reduction of Area, %.
0·2	Normalised	17·0	25·4	42·0	67·8
0·2	Annealed	9·0	21·2	42·3	65·7
0·4	Normalised	18·0	30·0	34·5	56·3
0·4	Annealed	9·5	25·0	35·0	57·0
0·6	Normalised	20·0	42·8	20·0	22·7
0·6	Annealed	11·4	31·9	26·0	23·5
0·9	Normalised	25·0	52·4	13·0	15·4
0·9	Annealed	16·8	36·7	18·0	21·0

## SOFTENING.

It will be recollected that two things were set out as the objects of the process of normalising, the one being the refinement or regeneration of the structure, and the other being the removal from the steel of all the stresses that had been put into it during the processes of rolling, forging, casting, case hardening, and the like. The former object was achieved by heating up the steel to a temperature slightly superior to its upper critical temperature, at which temperature the solid solution underwent a re-crystallisation, taking up the smallest and finest structure. This result can be achieved with all steels, whatever their type and whatever the nature or composition of the solid solution. The second object, namely, the removal from the steel of the mechanical stresses, is accomplished in the normalising process, by allowing the steel to cool through its critical temperatures at such a speed that the structural changes associated with these temperatures can take place without irregular interruption. This assumes that the steel does not become hardened in any way during the process of cooling and normalising.

satisfactory if it be applied to those steels which do harden when cooled in the air from the normalising temperature. Evidently, the objects sought for in the normalising process must be attained by other methods when such steels are being dealt with. The first object, namely, the refinement of the structure, is not affected by the fact that the steel becomes hard when cooled from its normalising temperature. The alteration of process is only required, therefore, in respect of the other objects, i.e., the removal from the steel of the stresses which are put in automatically by the hardening which occurs during cooling. This result can be achieved, most effectively, in the steels which harden when normalised, by tempering the steel, using the highest temperature, e.g.,  $675^{\circ}\text{C.}$ , which is possible for the operation. Such a treatment will remove the strains very effectively, and it is a debatable point whether the process of hardening and tempering, just described, is not superior to the normalising process in its effect, though it is inferior in convenience.

When a steel is tempered in the way described, simply to complete the changes usually brought about by normalising, the process is termed "softening," in order to distinguish it from the tempering operation as carried out for the purpose of producing, within the steel, some definite and precise value of tensile strength or notched bar toughness. The process does effectually soften the steel, giving it its minimum tensile strength, which is a convenience to the engineer for the purposes of machining.

The process of softening, just described, is the best practical method of meeting the difficulties experienced with the normalising of the air hardening (or semi-air hardening) alloy steels. Theoretically, and in fact, the alloy steels cannot be normalised, though the effects of the normalising process can be achieved, provided that the time allowed for the cooling is sufficiently protracted. To obtain the condition in an alloy steel, which corresponds to the normal state in carbon steels, would require an exceedingly slow cooling, probably lasting over several



days, though the desired results can be accomplished. Obviously, such a process becomes that of annealing. As a practical process, however, normalising or annealing the alloy steels is out of the question for most purposes.

#### MASS AND VOLUME EFFECTS IN HEAT TREATMENT.

Prior remarks regarding the processes of heat treatment have been concerned purely with alterations in structure produced during these operations, and with the fundamental reasons for carrying them out. There are several other points in connection with heat treatment which must not be overlooked, as they are of immense importance to the engineer. The first of these points is what is known as the "mass effect of heat treatment," and this is mostly connected with hardening. The process of hardening consists in "heating a steel to such a temperature that it is converted completely into solid solution, and cooling it at such a rate that the solid solution is retained intact or undecomposed when the steel reaches the temperature of the atmosphere." The mass of the steel part does not enter into the first operation mentioned in the definition, i.e., the temperature of hardening, except in so far as it must always be remembered that a much greater time is required for a bar 6 inches square to be heated throughout to a uniform temperature, than for a bar 1 inch square. The mass effect in hardening enters definitely into the second part of the definition, i.e., the cooling of the steel at such a speed as to prevent the decomposition of the solid solution.

From what was said earlier in this chapter regarding the cooling of steel, it must have become evident that every steel possesses a certain critical rate of hardening, i.e., that the solid solution, produced in the steel at the high temperatures, will decompose, unless it is cooled through the temperatures at which the critical changes occur, at such a speed that its temperature is falling at not less than a certain stipulated number of degrees per second. If this critical rate of cooling is attained or

will not decompose. If, on the other hand, the rate of cooling is lower than the critical rate, the solid solution will decompose to a greater or less degree, depending upon the extent of the departure of the rate of cooling from the critical rate.

Consider now the conditions under which a piece of steel, of reasonably large dimensions, cools when plunged into a bath of liquid. The outermost layer of steel in contact with the liquid cools most quickly. The next layer is cooled not quite so quickly, because its heat is not transmitted directly to the fluid, but has to pass through the outside layer of steel. This outer layer of steel has only a limited capacity of heat conductivity. The third layer of steel cools still more slowly, because of the increased thickness of metal through which its heat has to be conducted. Each successive deeper layer of steel, therefore, cools at a slightly slower rate than the layer immediately outside it, the rate of cooling of any layer being very approximately inversely proportional (*ceteris paribus*) to the logarithm of its proportional depth below the cooling surface. This means that, at some particular depth, a layer of the steel may cool at a rate slightly less than the critical rate of cooling required for the hardening of the steel of which it is composed, and, therefore, it will not be completely hardened, since the solid solution will partially decompose. This also means that all the layers lying deeper than this particular layer will not be hardened. The result is, that the outer shell of the steel part is hardened, but the interior is not, and consequently that the steel part is not homogeneous, either in structure or properties.

The effect described in the previous paragraph may be shown experimentally by two methods. Let two bars of the same steel be quenched in water from the same temperature, the diameter of one bar being  $\frac{9}{16}$  inch, and of the other 2 inches. After quenching, these two bars may be sectioned, polished, and etched. Where the

steel has been hardened, the etching fluid will produce practically no effect, but where the solid solution has decomposed, the etching will reveal it as a dark area. The result of a similar experiment is shown in Fig. 38, which makes it clear that the  $\frac{9}{16}$ -inch bar has hardened throughout, but that the larger bars have hardened only in the outer layers. The second method of displaying the phenomena is to make mechanical tests upon the sections of the bars. The results of such a series of tests are shown in Tables 5 and 6, and they indicate plainly the difference in hardness in the centres of the two bars.

TABLE 5.

MASS EFFECT OF HARDENING SHOWN BY THE MECHANICAL PROPERTIES OF BARS OF DIFFERENT SIZE HARDENED IN THE SAME WAY.

Steel.	Size of Bar, inches diam.	Position Tested.	Heat Treatment.	Max. Stress, tons per sq. in.	Elongation, %.
0.85 % carbon	9/16	Centre	Water quenched from 850° C.	97	2
	2	Edge	Water quenched from 850° C.	89	5
	2	Centre	Water quenched from 850° C.	56	25

TABLE 6.

EXHIBITION OF MASS EFFECT BY BRINELL HARDNESS DETERMINATIONS UPON TWO DIFFERENT STEELS, EACH TREATED IN TWO DIFFERENT SIZES.

Steel.	Size of Bar, inches diam.	Position Tested.	Heat Treatment.	Brinell Hardness Number.
0.45 % carbon	9/16	Centre	Water quenched from 850° C.	388
	2	Edge	Water quenched from 850° C.	363
	2	Centre	Water quenched from 850° C.	262
0.85 % carbon	9/16	Centre	Water quenched from 850° C.	555
	2	Edge	Water quenched from 850° C.	578
	2	Centre	Water quenched from 850° C.	311

It was shown earlier in this chapter that the critical rates of hardening of all steels are not the same. This is really what is meant by the statement that some steels harden in air, some require to be cooled in oil, and others often require to be cooled in water. Obviously, then, to the engineer it may be of great importance that, for parts of large mass, he shall employ a steel which has a low critical rate of hardening, in order that the steel in the interior of the part shall cool fast enough to be hardened. This is obviously most important in forgings which are subsequently to be machined. For most engine parts which are heat treated to produce definite mechanical properties, it is most desirable that homogeneity should be produced. On the other hand, in the treatment of other things, particularly tools such as taps, milling cutters, etc., attempts are made to confine the hardening effect to the skin of the part, and to prevent it spreading throughout the tool. In such articles advantage is taken of the phenomena of the mass effect.

Mass effect is of no importance in the tempering process. In this operation the critical factor is the temperature to which the steel has been heated, and, apart from temper brittleness (see p. 185), the rate of cooling does not enter at all. Where a steel is being cooled quickly after tempering in order to avoid temper brittleness, it is possible that the rate of cooling would have to be taken into account along with the mass, but the mass of the part would need to be very great if cooling in water did not produce the desired effect.

In the normalising process the effect of mass is not quite negligible. In order to attain all the results desired from this operation, it is necessary for the steel to pass through the critical temperatures at a speed lower than its critical rate of hardening. Unless it does so, the steel will harden to some extent, and, by so doing, will not obtain the full benefit of the normalising process, because it will not be entirely free from mechanical strains. With the alloy steels such hardening always occurs if normalising

is attempted, the process being, therefore, an impossible one for such steels for that reason. With the carbon steels something of the same kind of result may be obtained if the part is of such a mass that the rate of cooling in air is fairly rapid. Even with such parts as railway tyres the effect can be observed, whilst with thin strip the effect is quite marked. The whole question is one of rate of cooling. The carbon steels are not fully hardened during the air-cooling process, but are half hardened—the full normalising effect not being obtained.

The second point of great importance to the engineer, in connection with heat treatment, is the volume changes which occur during the various processes. These are of two kinds, the normal expansion and contraction (in accordance with the thermal expansion of metals) due to the changes of temperature which occur in the treatment, and the abnormal changes of volume which occur at the critical temperatures of the steel. These can be separated for purposes of discussion, though they are necessarily inseparable in practice. The normal thermal coefficient of expansion of steel may be taken to be more or less equal to that of pure iron, which is  $11 \times 10^{-6}$  in C.G.S. units. It is found, also, that this value is more or less constant at all temperatures up to  $950^{\circ}\text{C}$ ., i.e., throughout the ordinary range of temperatures used in the heat treatment of steels. The normal coefficient of expansion of steel means that when a steel cools from, say,  $850^{\circ}\text{C}$ . to the temperature of the atmosphere, it undergoes about 1 per cent. of linear contraction, and about 3 per cent. of volume contraction. This amount of contraction, i.e., 3 per cent., will occur, whatever may be the method of cooling the steel, or the speed at which it takes place, that is, whether the cooling is carried out in air or in water. Its effects are worth a careful examination.

In the first place, the case of a simple cylinder, i.e., a moderately long bar, may be noticed. The ends of the bar may be neglected. The cooling of the cylinder is from  $700^{\circ}\text{C}$ . (i.e. below the lower critical temperature)

and is effected by dropping into water. The outside layer of the cylinder will cool down to the temperature of the water almost instantaneously, and, therefore, will immediately tend to undergo its full amount of contraction. The layer immediately below the surface which does not cool quite so rapidly will not have reached the temperature of the water at the time that the outside layer has reached it. As a result, the second layer will not have contracted by its full amount, i.e., it will occupy a slightly larger volume than it will when it has attained the temperature of the first or outside layer. The same thing happens to the third and fourth layers, and the result is, that throughout the steel part, there is a gradient not only of temperature, but of "excess volume" or delayed contraction, varying from nothing on the outside to approximately 3 per cent. in the middle, at the instant of quenching. The effect of this excess volume in the inferior layer means that the superior layer is being stretched. It is a case of a number eight boot on a number nine foot. The result on the steel is much the same as it would be upon the boot. The superior layer has to yield because the inferior layer cannot contract as much as it subsequently will, and, therefore, the superior layer cannot contract as much as it normally would. The outer layers of the steel are, therefore, called upon to stretch momentarily—during the time required for the lower layer to attain to the temperature of the one above it—or else to burst. There are no alternatives. Except under the most exceptional circumstances, the steel stretches and accommodates the stresses, and, therefore, does not burst. As it does not burst, the whole piece of steel assumes a state of normal dimensions, when a uniform temperature has been established throughout the steel, and the strain in each layer, due to the "excess volume" of the layer below it, is taken off. This will happen when the quenching temperature is  $700^{\circ}$  C. or lower, because there are no other factors to take into account. What is quite evident, and this is the important

thing, is that, even during the quenching of the most simple specimens of steel imaginable, the outside skin is subjected to a stress which may be of considerable magnitude, though this stress, when it is due simply to ordinary thermal expansion and contraction, is in no normal case large enough to cause fracture.

The abnormal changes of volume which occur during heat treatment, and more particularly during hardening, must now be considered. At the beginning of this chapter it was shown that at certain temperatures, known as the critical temperatures, the steel undergoes definite structural changes, and it was further shown that there was a distinct similarity between this occurrence and the freezing of a liquid solution, such as salt in water. The similarity between the two systems may be extended beyond the limits described above, by recalling what happens when water freezes in a bathroom pipe, or in the water jacket of a motor-car cylinder. It is not at all uncommon, under these circumstances, for the bath pipe or the cylinder jacket to burst, in consequence of the fact that, at the time of freezing, the water expands by a considerable amount. Precisely similar changes occur in the steel at the critical temperature. When a steel cools through its lower critical temperature it expands, and when it is heated through this temperature it contracts, i.e., it suffers an abnormal volume change at the critical temperatures. The nature of the volume changes can be seen most easily from the curves given in Fig. 39. It is to be observed particularly, that the abnormal change of volume which occurs at the critical temperature during heating or cooling, is exactly the reverse of the normal changes which are occurring during the same process, i.e., that the cooling steel which normally is contracting, expands suddenly at the critical temperature, and that the steel during heating contracts at the critical temperature. There is, however, an important difference between the normal and the abnormal changes of volume. The normal changes of volume are practically independent of

the structure of the steel, but the abnormal, on the other hand, depend entirely upon the structural changes, being, in fact, a reflection of them. This, of course, is what would be expected. Unless the water froze in the bath pipe the burst would not occur. If the water could be cooled down to a temperature below its freezing-point, without any freezing taking place, no abnormal expansion would occur. The expansion is an accompaniment of

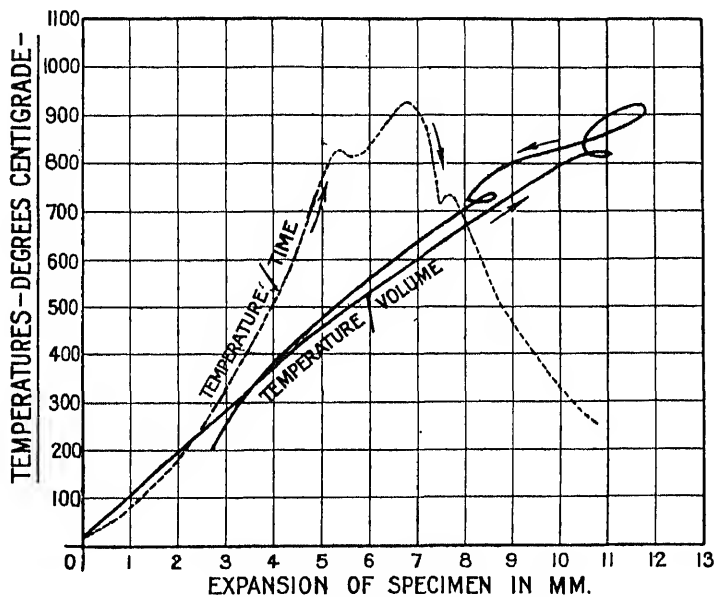

FIG. 39.—CURVES SHOWING CHANGES OF VOLUME OCCURRING IN A STEEL AT DIFFERENT TEMPERATURES.

the change of state. Similarly with the steel, the sudden change of volume accompanies the sudden change of structure. If, therefore, the steel is cooled so quickly that there is no change of structure, it is to be expected that there will be no sudden change of volume. When it had cooled down rapidly to normal temperatures, the steel would have a different volume from that which it would have if it had cooled down slowly, because the solid



solution, which was fixed by the rapid cooling, has a different specific gravity from that of the pearlite to which it would give rise if slowly cooled. The volume would not, however, undergo any sudden alteration. It is very rarely that a piece of steel is hardened throughout its mass to the same extent, and particularly rarely in parts made of carbon steel. This means that, in the majority of parts, the steel part is hardened on the outside to a greater degree than it is on the inside. In other words, there has been some structural change in the interior and none in the exterior of the steel, the result being that the volume change, which has taken place in the various layers of the part during the quenching, is different. The effect of this is that, at some time during the cooling, the interior of the part has undergone a sudden expansion, and therefore has put a good deal of stress upon the outside layers of the part. This stress may be quite sufficient, and under many circumstances frequently is sufficient, to cause the part to break by the bursting of the outside layers. The expansion of the interior occurs when the exterior has cooled considerably, and has become more or less rigid in consequence. It is, therefore, less ductile, and less able to accommodate itself to the stresses imposed without undergoing fracture. Anything which tends to exaggerate the stress produced in this way is almost certain to result in the breaking of the part.

Having examined what takes place in a simple example, the more complex cases may be examined. Imagine, for instance, what occurs if a sharp notch is present in the surface of the steel. It is well established that the presence of such a notch will cause a local increase in the magnitude of any stresses which may be put upon the steel (see Appendix A, p. 293). The stress exerted upon the outside of the steel by the excess volume, and the expansion of the interior, means the existence of a considerable stress on the steel in the outer layer. This already considerable stress may, by the presence and form

of the notch, be magnified to such a value as will cause the rupture of the steel. The existence of a notch on the surface of the steel part is not such a rare occurrence as might be imagined. A sharp tool mark or a sharp corner gives precisely the same effect.

Another complex case which may be imagined is that in which there is a considerable difference of mass in the various portions of the steel part. Such a shape, for instance, as is shown in Fig. 40 is easy to examine. The mass of the part marked A is considerably smaller than that of the part marked B. Evidently, therefore, there

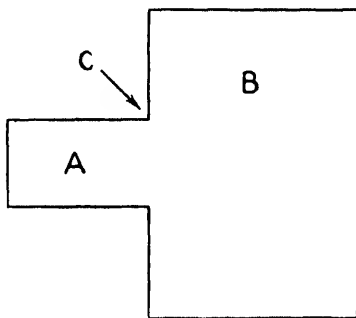

FIG. 40.—DIAGRAMMATIC ILLUSTRATION OF  
A TYPICAL FORGING.

will be a distinctly greater contraction (total) in B than in A. Probably, also, there will be in part B a greater stress placed momentarily upon the skin of the part than in the skin of part A. Also, since the part B is of greater mass than part A, there will be a greater proportion of part B which is not hardened than of part A. Hence the sudden change of volume at the critical temperature in the part B will be greater than in part A. The skin of B, therefore, may be expected to be stressed to a greater extent than that of part A. The two parts A and B are, however, joined together at C. At this section the two skins of steel meet, i.e., the two parts of the steel

which, in the quenching operation, are most highly stressed. Furthermore, it is extremely probable that the stresses in the skin in the two different parts are acting in opposite, or at any rate different, directions, thus increasing the actual stress at the section C. This stress alone might conceivably be sufficient to cause a fracture at C, and the possibility is turned into a probability, or a certainty, unless the radius at the section C is made large enough to avoid undue concentration of the stresses. To the engineer such considerations are of the most extreme importance. Sufficient has been said, however, upon this subject to make the other cases which might arise, e.g., the different parts of the article being heated to different temperatures, capable of easy treatment.

It is important to note carefully that the destructive volume changes are those which occur at the critical temperatures, i.e., the abnormal volume changes. The normal volume changes due to the ordinary thermal expansion and contraction do not by themselves produce fractures of parts during quenching. It is only when the abnormal volume changes occur, as a result of sudden changes of structure, that failure of the part results. It is, of course, quite probable that the smaller stresses produced by the normal expansion and contraction, add to the severity of the stresses produced by the abnormal expansion, and thereby assist to produce failure, but, by themselves, they are never sufficiently severe to cause the steel to break.

Volume changes during tempering are important, but, as a rule, are not at all dangerous. Naturally, from what has already been said, a steel which is quenched, and has, therefore, an abnormal structure, has also an abnormal volume. During tempering, the structure of the steel tends to return to the normal, and, therefore, the volume also tends to change in the same way. This rectification of the volume can be seen most easily from specific gravity

TABLE 7.

THE CHANGES OF SPECIFIC GRAVITY PRODUCED BY TEMPERING HARDENED STEEL.

Tempering Temperature, °C.	Specific Gravity.
15	7·798
100	7·806
200	7·813
300	7·829
400	7·843
450	7·850
500	7·847
600	7·845
700	7·840
800	7·837

In normalising, the volume changes are of no importance.

#### THE ENGINEERING VALUE OF HARDENED AND TEMPERED STEEL.

It appears desirable at this point to investigate the question which must necessarily arise frequently in the mind of the inquiring engineer, as to the value to him of heat treated steel. The various heat-treatment processes which have been described cannot be carried out without some expenditure of time and money, and the engineer naturally wishes to know what return he is likely to obtain for this dual expenditure. The value of such processes as softening, normalising, and annealing is comparatively easy to appreciate, but it is perhaps not so simple to realise what advantage accrues from the combined process of hardening and tempering, when they result in the production of comparatively soft steel. To put the problem in a precise form, there are many occasions when the engineer designs a part which is required to have a strength such as can be produced, with equal readiness, in steel which has simply been normalised,

and has not been hardened or tempered, or in steel which has been hardened and tempered. Which of these two steels is the engineer to employ? The answer is undoubtedly that he should employ the hardened and tempered steel whenever possible. An appreciation of the reasons for this choice necessitates an examination of the essential properties of steel in the light of the requirements of the engineer. For his purposes, steel should possess a certain definite tensile strength, accompanied by an adequate degree of toughness and an adequate degree of ductility. The need for a certain amount of toughness requires no explanation, as it is obvious that an engineer prefers a steel which is tough to a steel which is brittle. The desirability of a steel possessing a reasonable degree of ductility is perhaps not so evident, since engineering structures are expected to be more or less rigid, and are not expected to flow. The ductility of a steel only becomes apparent when the steel is flowing, and not when it is rigid. Reasoning on these lines suggests that the ductility of the steel is a matter of little importance, and this argument might probably lead to an accurate result, were it not for the fact that the rigidity of an engineering structure, or the parts of a prime mover, is only relative, and that there may be occasions when it is necessary for the steel to flow appreciably in certain small portions or elements, although the flow of the complete structure, or of the engineering member as a whole, is inappreciable.

In Appendix A, an account is given of the effect of sudden changes of section, or of sharp corners, etc., upon the distribution of stress in steel parts. It is shown in that appendix that, under certain circumstances, the stress in the steel round the sides of a notch, or in the region at which there is a sharp change of section, is a great deal higher than that obtaining in any other portion of the structure. Sharp changes of section are difficult to avoid. The designer may exercise every possible precaution in avoiding them deliberately, but his inten-

ions may be frustrated completely by inadvertent carelessness on the part of the workmen. Tool marks, hair cracks, etc., may, and undoubtedly do, cause a considerable variation in the distribution of stress in the skin of a part, and these irregularities may, at any time, develop into such dimensions as produce a dangerous concentration of stress around the sides of the flaws. Even the corrosive action exercised by the atmosphere upon exposed parts is sometimes sufficient to develop surface flaws which become dangerous. In general terms, the only satisfactory way of reducing this concentration, and, therefore, producing a safe distribution of stress in the metal, is to remove the small radius or sudden change of section. The only automatic method of accomplishing this is by plastic flow on the part of the steel. Plastic flow means distortion, and a capacity for distortion under static loads, without fracture, indicates what is generally inferred by the term ductility. It is desirable, therefore, from the point of view of the rectification of undue and irregularly distributed stresses in steel parts, that the steel shall be capable of undergoing a certain amount of distortion without fracture. In other words, the steel must possess a reasonable degree of ductility.

The extent to which the steel may be required to distort in order to overcome an unsatisfactory distribution of stress may be comparatively large, when the small volume of steel involved in the actual distortion is considered. The degree of distortion necessarily depends upon the smallness of the radius involved. If, however, it is considered that the actual portion of the steel part which is to distort is perhaps only one-hundredth of an inch deep and one-hundredth of an inch long, an elongation of 20 per cent., in this particular volume of steel, will have an inappreciable effect upon the general dimensions of the part in which the distorting steel element happens to be situated.

It may be taken, therefore, as being proved that the engineer requires steel which possesses adequate strength,

adequate toughness, and adequate ductility, in one and the same piece. It is necessary now to investigate what is the effect of heat treatment upon these different properties of the steel. It is quite easy to consider this effect from the standpoint of the structure produced in the steel after the different treatments. A reference to the micro-photographs illustrating the structures of carbon steels which have been given earlier in this chapter makes it clear that there is a very large and distinct difference in the structure of steels heat treated in different ways. For the purposes of the present examination it is only necessary to refer to the structure of steels which have been (a) normalised, (b) hardened, (c) hardened and tempered, and typical structures are shown in Figs. 36, 30 and 34. The structure of the normalised steel as shown in Fig. 36 is obviously heterogeneous. The metal evidently consists of at least two different constituents, one on the photograph being white, and the other being dark grey or black. It was shown earlier in this chapter that the white constituent is iron, and the dark constituent is pearlite, which is a mixture of iron and carbide of iron. This heterogeneous structure is evidently capable of acting to some extent, when stressed, like a mixture. Since there are large (relatively) masses of iron present, this particular constituent will be able to exert its own influence upon the properties of the whole mixture. It has been shown clearly above, that a steel of the structure shown in Fig. 36 has no great strength, as might reasonably be expected from the fact that it contains so much free iron, and iron is not conspicuously notable for its tensile strength. On the other hand, it may be expected that there will be a reasonably high degree of ductility, since iron distorts freely. The toughness of this steel will depend to some extent upon the circumstances under which it is being stressed. If the steel is free to distort, it will probably have a high toughness value, because, since there is a good deal of free iron in the part (and this constituent is notably ductile), the iron may distort,

required to produce the fracture, i.e., in other words, to increase the toughness. On the other hand, the existence of the large masses of free iron provides the possibility of the presence of extensive and uninterrupted gliding planes, which tend to allow a crack to propagate itself with comparative ease. If the steel is not free to distort, it is probable that the latter influence will be paramount, and, therefore, that the steel will not show any particular degree of toughness. Even if the steel is free to distort, it is probable that the existence of the gliding planes tends to reduce the toughness in a notable degree.

Turning to the structure of the hardened steel as shown in Fig. 30, it is evident that the conspicuous feature of the structure of fully and correctly hardened steel is its homogeneity. The solid solution in the steel possesses a considerable tensile strength, but since it is composed entirely of homogeneous crystals of solid solution, the resistance to the spread of cracks (or the toughness of the steel) is comparatively low. The steel is homogeneous, and, therefore, the conditions which were shown to hold for those parts of the crystals of the normalised steel which were formed of free iron will hold also for the solid solution, except that the hard steel does not distort so easily as does the iron in the normalised steel. It would be expected, as is known to be true, that hardened steel, containing nothing but solid solution, would be by no means tough.

The third type of structure is that presented by a hardened and tempered steel. In Fig. 34 the structure shown is that of a steel, which, after hardening, has been tempered at a relatively high temperature, and this particular structure has been chosen for purposes of illustration, because it shows, on a scale which can be appreciated optically (what is almost equally prevalent, though not so obvious in all steels which have been tempered), the particles of precipitated carbide which



have attained to such dimensions as render them easily visible. It is known quite well, that the strength of hardened and tempered steel is less than that of fully hardened steels, consisting purely of solid solution, presumably in virtue of the precipitation, during tempering of a more or less large proportion of carbide from solid solution. The toughness, however, of steel with the hardened and tempered structure, is very considerable. This may be imagined easily. In the first place a crack starting at one side of a crystal of tempered steel, has a straight and easy path to travel if it is to reach the other side of the crystal. The crack is not likely to pass through the precipitated carbide, but to go round it, which means that after traversing only a very small thickness of solid solution (or iron) the crack is brought up short by meeting with a particle of precipitated carbide. When the crack meets the carbide it most probably travels round it, and therefore work has to be done in changing the direction of propagation of the crack. After it has reached the other side of the particle of carbide the crack has to choose a new path, and it actually may have to create a fresh crack on the far side of the particle of carbide. This absorbs a considerable amount of work, particularly as the matrix of iron, or largely decomposed solid solution, is ductile, and will distort freely before a crack can commence. It is evident, therefore, that steel possessing such a heterogeneous structure as is found after tempering will, in general, be notably tough, which as a matter of fact, is well known to be true.

From what has been said above, it should be evident that where the same strength can be obtained in two steels, one of them a normalised steel, and the other a hardened and tempered steel, the toughness values are found to be very much higher in the hardened and tempered steel than in the normalised steel. Since an engineer desires the optimum condition of mechanical excellence in his material, and, therefore, requires a high toughness value, he necessarily will choose the harde

and tempered steel, in preference to the normalised steel, whenever possible. The test results shown in Table 8 indicate the difference in toughness between normalised and hardened and tempered steels when both are of approximately the same tensile strength.

TABLE 8.

THE VARIATION IN TOUGHNESS IN STEELS OF THE SAME MAXIMUM STRESS HEAT TREATED IN DIFFERENT WAYS.

Steel.	Heat Treatment.	Max. Stress, tons per sq. in.	Elongation, %.	Reduction of Area, %.	Impact, ft.-lb.
0.45 % plain carbon	Normalised	42	28	55	29
0.45 % plain carbon	Hardened and tempered	42	27	66	57
0.28 % plain carbon	Normalised	36	27	57	43
0.28 % plain carbon	Hardened and tempered	40	29	64	93
3 % nickel ..	Normalised	44	28	56	33
3 % nickel ..	Hardened and tempered	49	28	66	94

## CHAPTER IV

### MECHANICAL TESTING OF STEEL

IT is of the utmost importance that the mechanical properties of a piece of steel should be known accurately, before it is used in parts performing any high duty. The steel will finally be judged upon the basis of its mechanical properties. Details of composition, heat treatment, etc., are of great interest, but they are really only of secondary importance, being merely means to an end, the end being the mechanical properties which they produce in the steel. No amount of nickel or chromium will make a steel do its work as a crankshaft unless the mechanical properties required in the crankshaft are present as well. If an engine part made in carbon steel breaks, there is an unfortunate tendency to assume immediately that a nickel steel should be used, and that its employment will prevent any further fractures, rather than to inquire what are the mechanical properties of the carbon steel, and in what way these mechanical properties should be improved, in order to make the steel stand up to its work. It may be found desirable to use a nickel steel in order to obtain the requisite physical properties, but that is only a secondary matter.

In view of these facts, it will be well to inquire what are the important mechanical properties of steel, and to consider how these properties may be determined and evaluated. The properties usually indicated by the mechanical tests made on steel are:—

- (1) Elastic limit in tension, compression, or torsion.
- (2) Yield-point in tension, compression, or torsion.
- (3) Maximum stress in tension or torsion.
- (4) Elongation per cent.
- (5) Reduction of area per cent.
- (6) Brinell hardness.
- (7) Impact or notched bar value.
- (8) Capacity for bending.
- (9) Resistance to alternating stresses.
- (10) Fatigue range (or strength).
- (11) Scleroscope hardness.

#### METHODS OF TESTING STEEL.

The various pieces of information detailed above are accumulated by carrying out a variety of tests. By performing a **Tensile Test** in an appropriate manner, it is possible to determine the Elastic Limit (see discussion of this below), the Yield-point, the Maximum Stress, the Elongation per cent., and the Reduction of Area per cent. A simple **Torsion Test** gives the Elastic Limit, the Yield-point, and the Maximum Stress. A simple **Compression Test** gives the Elastic Limit and the Yield-point. The methods usually employed for making tensile compression and torsion tests are sufficiently well-known to require no further description here.

One point, however, should be noted in connection with the carrying out of tensile tests. It is of vital importance, if truly accurate results are to be obtained from a tensile test, that the load on the specimen should be applied in a direction exactly parallel to the axis of the test piece. Axial loading is of greater importance when testing brittle materials and high tensile steels, than for other classes of steel, but it is desirable that it shall be applied in every test. To secure this method of loading, attention must be paid to the shackles of the testing machine. One very satisfactory form of shackle to ensure axial loading of the specimen, was

When making tensile tests on certain kinds of steel—particularly brittle steels and sheets—the test piece frequently breaks outside the gauge length. This makes it impossible to determine satisfactorily the elongation and reduction of area on the specimen. In order to prevent the specimen breaking outside the gauge length, this portion may be tapered slightly, so that the middle third of the gauge length is of a somewhat smaller diameter than the extremities. This constriction usually causes the test piece to break in the middle part of the gauge length, and consequently permits of the full information being obtained from the test. The usual amount of reduction in the diameter of the gauge length is to 0.561 inches from 0.564 inches (and proportionately) in round specimens, and to 1.24 inches from 1.25 inches in test strips from sheets.

For the determination of the elastic limit of the steel, it is necessary to employ an extensometer. This is an instrument which may be attached to the gauge length of the test piece, and which registers the strain produced in the steel by the various stresses imposed. The strain is usually measured in ten-thousandths of an inch. By plotting the values of the strain, i.e., extension of the steel in ten-thousandths of an inch, against the stress producing the strain, a stress-strain curve similar to that shown in Fig. 51 is produced. Various forms of extensometer have been devised and put on the market.

**The Brinell Hardness Number** of a steel possesses a courtesy title when it is described as a "hardness" number. The Brinell test is carried out by pressing a hardened steel ball, with a known pressure, on to a flat surface produced on the steel which is to be tested. The ball used is usually 10 mm. in diameter, and the load for ordinary steel tests is usually 3,000 kilograms. The loaded ball sinks into the steel and leaves a spherical impression. The depth of the impression varies (roughly)

inversely as the "hardness" of the steel (as generally understood). The Brinell hardness number is the load in kilograms, divided by the area of the spherical surface of the impression in square millimetres—so that the smaller the impression, the larger is the Brinell number.

By the comparison of the results of a large number of tensile and Brinell tests, a distinct relationship between the Brinell hardness number and the maximum stress of the steel has been established, with a reasonable degree of accuracy. This relationship cannot be expressed absolutely, since the ratio of maximum stress to Brinell hardness number varies a little with the nature of the steel under examination. The variation in ratio is from 0.22 to 0.24, the lower ratio being given by those steels which have been heat treated by hardening and tempering or by normalising, whilst the higher factor applies to those steels which have been annealed, and which consequently give a low ratio of yield-point to maximum stress.

Table 9 (on p. 92) gives the Brinell hardness number corresponding to the various diameters of impressions produced with a load of 3,000 kilograms. It also gives the maximum stress which generally corresponds to each of these Brinell hardness numbers, using the two factors 0.22 and 0.24.

The method of making Brinell hardness determinations is well-known. There are several machines on the market for carrying out the test, including the original Swedish machine, the Derihon machine, and the Johnson machine. Drawings of these three machines, and brief descriptions of them, are given in Appendices I, J, and K.

In connection with the Brinell test, there are several points which should receive attention. In the first place, there is a distinct tendency to overload the specimen, unless care is exercised. The load should never exceed that stipulated (e.g., 3,000 kgs.), even momentarily, or else the results will be vitiated. It is necessary that the flat surface on which the Brinell test is to be made

should be carefully prepared before the load is applied. All scale and rust must be removed. This may be done by machining, or by filing, or by grinding. If the latter method is employed, then the grinding must be done carefully to avoid the overheating of the surface which may otherwise ensue, and the consequent change in

TABLE 9.  
BRINELL HARDNESS NUMBER AND MAXIMUM STRESS  
EQUIVALENTS.

Diameter of Impression in Millimetres.	Brinell Hardness Number.	Max. Stress, tons per sq. in.		Diameter of Impression in Millimetres.	Brinell Hardness Number.	Max. Stress, tons per sq. in.	
		Factor 0·22.	Factor 0·24.			Factor 0·22.	Factor 0·24.
2·40	653	144	157	4·40	187	41	45
2·50	601	132	144	4·50	179	39	43
2·60	555	122	133	4·60	170	37	41
2·70	514	113	124	4·70	163	36	39
2·80	477	105	114	4·80	156	34	37
2·90	444	98	106	4·90	149	33	36
3·00	415	91	100	5·00	143	31	34
3·10	388	86	93	5·10	137	30	33
3·20	363	80	87	5·20	131	29	31
3·30	341	75	82	5·30	126	28	30
3·40	321	71	77	5·40	121	27	29
3·50	302	66	72	5·50	116	25	28
3·60	285	63	68	5·60	111	24	27
3·70	269	59	65	5·70	107	23	26
3·80	255	56	61	5·80	103	23	25
3·90	241	53	58	5·90	99	22	24
4·00	229	50	55	6·00	95	21	23
4·10	217	48	52	6·10	92	20	22
4·20	207	45	50	6·20	89	20	21
4·30	197	43	47	6·30	85	19	20

(The maximum stress values are given to the nearest whole ton.)

physical properties which might follow from the overheating (i.e., tempering, etc.).

Some materials, which are to be subjected to the Brinell test, are very soft, and it may be thought desirable to

happen that the surface available for the test is too small to allow of the production of a full-sized impression without bulging the sides of the specimen, which would destroy the value of the test. Under either of these conditions, it is customary to employ a load of 500 or 1,000 kgs. The usefulness and accuracy of the results obtained with these loads from steel is open to some doubt, as the Brinell number obtained with the small load is not quite the same as that obtained with a standard load. It might be expected that the Brinell numbers obtained with the two different loads would be the same, but in actual practice they are found not to be so, and the result obtained with the smaller load may be misleading. It is preferable to use the larger and standard load whenever possible. (A fruitful source of inaccuracy is the difficulty of reading the very small impression produced on most steels with a 500-kilogram load.)

The Brinell test is exceedingly useful as indicating a sound approximation to the maximum tensile strength of the steel under test. Whether it gives any correct idea of the hardness of the steel, is open to serious doubt. It is impossible to say whether or not the real hardness of the steel is indicated by the test, since, up to the present, no true and universally applicable definition of hardness has been evolved. For most purposes, the hardness may be regarded as the resistance which a material exerts against deformation, and in the case of a homogeneous metal, this is equivalent to saying that the hardness is measured by the yield-point—or by the ultimate strength, depending upon the type and magnitude of the deformation. Since the Brinell test gives a reasonable measure of the ultimate strength, it may be regarded in this degree as measuring the hardness. Its use as a hardness measure must be kept, however, within the limits indicated. So far as is known, the perfect hardness test has yet to be discovered (see Bibliography in Appendix N for original papers on this subject).



**The Impact or Notched Bar Value** of a steel is usually determined nowadays by methods which agree in principle, but vary, to some extent, in detail. The principle of the test is that a piece of steel shall be notched on one side, and then fixed in a machine so that it can be broken by a single blow from a falling weight, or from a heavy swinging pendulum (see Fig. 41). There has been a good deal of controversy as to the form of the notch which should be employed. At the present time there are only two forms in wide use—the Izod notch

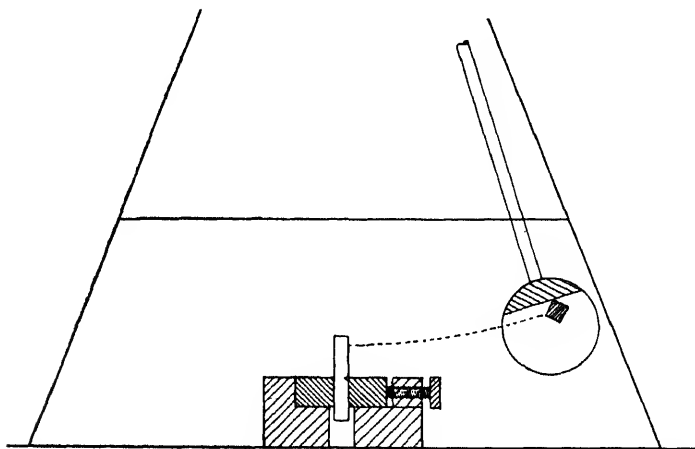

FIG. 41.—DIAGRAMMATIC REPRESENTATION OF IZOD IMPACT TEST.

and the Mesnager notch. These two are shown in detail in Figs. 42 and 43. The former notch is likely to be standardised in this country, and is the one which has been utilised in drawing up the specifications for steel for aeronautical and other purposes. The relative advantages and disadvantages of the various shapes and forms of notches have been discussed in many papers (see Charpy,<sup>1</sup> Philpot,<sup>2</sup> etc.). In this book all the impact results quoted (unless otherwise stated) have been ob-

<sup>1</sup> *Journ. Iron and Steel Inst.*, 1917, ii.

<sup>2</sup> *Journ. Inst. Automobile Engineers*, 1918.

tained from specimens carrying the IZOD notch. The main reason for the adoption of this notch appears to

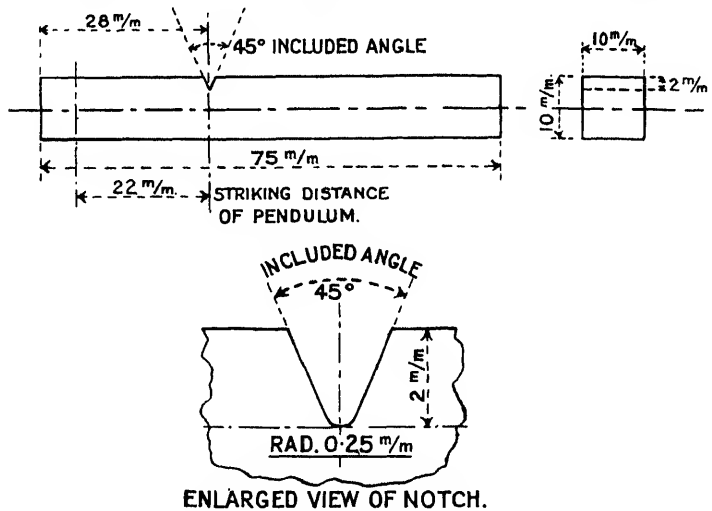

FIG. 42.—STANDARD IZOD IMPACT TEST PIECE AND NOTCH.

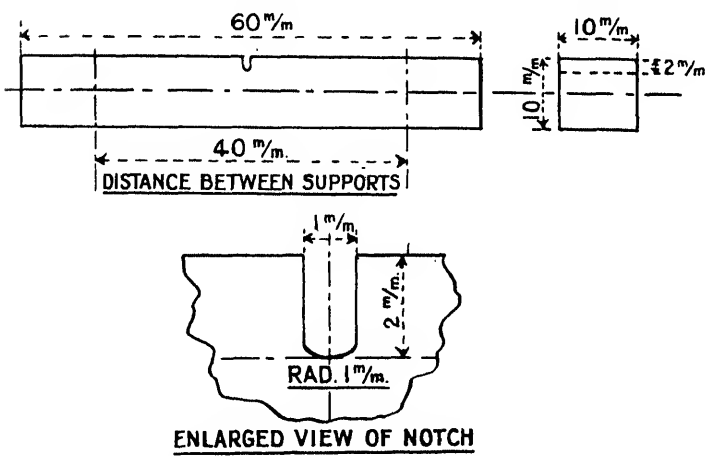

FIG. 43.—STANDARD MESNAGER IMPACT TEST PIECE AND NOTCH.

have been, that it gives a more perfect discrimination between materials with a high and a low impact value

than does any other form of notch. For example, several steels—some low and some high in impact value—gave the values shown in Table 10 with the Izod and the Mesnager notches.

TABLE 10.

NOTCHED BAR VALUES ON STEELS BEARING DIFFERENT NOTCHES.

Steel.	Izod.	Mesnager.
I	62 ft.-lb.	70 ft.-lb.
II	62 ft.-lb.	76 ft.-lb.
III	8 ft.-lb.	40 ft.-lb.
IV	11 ft.-lb.	32 ft.-lb.

The results obtained with both notches from steels with high impact values are very similar, but from steels with low impact values the Izod notch is more sensitive, giving a much lower value than that recorded by the Mesnager notch.

The form of machine used for carrying out the tests does not matter a great deal. This has been proved by various workers. The two most usually employed are the Izod and the Charpy, the former being most frequently used in this country, and the latter, in France. The two machines are shown in Figs. 44 and 45, whilst more complete descriptions of the machines, with drawings, are given in Appendices E and F. Methods for calibrating the two machines are given in Appendix F.

**Bending Tests** are usually only carried out on bars or on sheet steels. In many workshops they are done in a very rough-and-ready manner, often with unsatisfactory results. Sheet steel is more often tested by bending than any other form, and for such steel it is desirable to carry out the bending in some properly designed machine, if possible. In America, the method of testing

adopted with some success. The two points connected with the use of this method which require attention are,

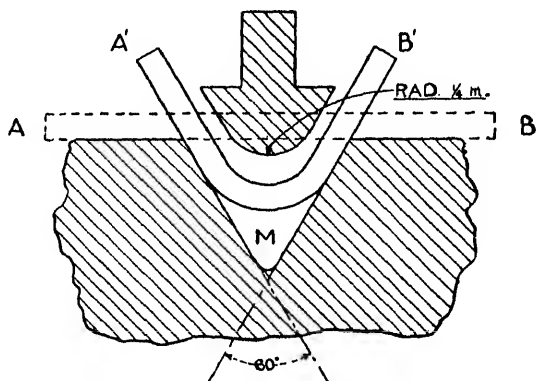

FIG. 46.—METHOD OF CARRYING OUT BEND TEST, SHOWING INSERTION OF DIE.

that the forming tool should have a radius at the nose which varies with the thickness of the sheet, and that when the sheet is being bent into the 180° position a suitably rounded spacer should be introduced between

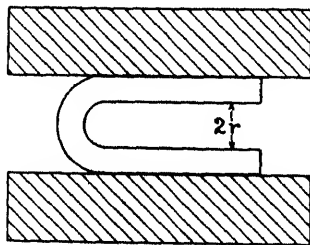

FIG. 47.—METHOD OF CARRYING OUT BEND TEST, SHOWING FINAL POSITION OF SPECIMEN.

the two sides of the bent sheet. By taking these precautions, the danger of cracking the test piece, by bending it over too small a radius, can be lessened. Kinking may

easily happen in consequence of the crinkling or buckling up of the sheet, unless proper steps are taken to avoid it. For many purposes the information called for in a bend test is knowledge as to how the steel will behave when worked with press tools or forming rolls. Very sound information of that kind is provided by the tests made with the Atcherley bender, drawings and a description of which are given in Appendix M.

For many forms of steel, particularly sheet, it is desirable to test, not only the capacity of the metal to bend, simply and plainly, through  $180^\circ$  over a specified radius, but also its capacity to bend backwards and forwards through a considerable angle without developing a fracture. The method of carrying out the **Reverse Bend Test** on sheets is seen clearly in the following extract from the British Standard Specification for mild steel sheet for aircraft. "The strip is to be fixed in a vice which has the inner edges of the jaws rounded to a radius equal to three times the thickness of the sheet. The projecting end of the strip is then to be bent at right angles to the fixed part, first to one side, then to the other, for a number of times until it breaks. The strip must stand without cracking at least three such reversals. The first bend through  $90^\circ$  is not counted." This test, known as the "reverse bend test," should always be carried out in a machine specially designed for the purpose. One such machine is described in Appendix L. In this test, as in the plain bend test, it is essential that the radius over which the steel is to be bent should be a function of the thickness of the sheet (or the diameter of the bar, if bar steel is to be tested). The reverse bend test is a fairly sensitive one, and in consequence of the fact that on sheet steel the values for elongation and reduction of area, i.e., the usually accepted indications of ductility, are not to be relied upon, since they vary too much with the gauge of the sheet, this test supplies the best and most convenient way of determining the ductility of the sheets.

**Resistance to Alternating Stresses** is not a test undertaken in the ordinary routine of testing. Several methods have been proposed, however, for subjecting a steel to such a test. These vary somewhat in character, but all of them lie midway between the simple reverse bend test just described (which in itself is an elementary form of alternating stress test), and the true fatigue test described below. In most of the alternating stress tests it is customary to stress the material to a more or less unknown amount, the actual stress being selected arbitrarily. The results obtained are consequently very difficult to evaluate. Three such tests are: (1) The Arnold alternating stress test, (2) the Stanton alternating stress test, and (3) the Upton Lewis alternating bend test.

The Arnold test uses a cylindrical test sample 5 inches long and  $\frac{3}{8}$  inch in diameter. The specimen is gripped at one end, and then is bent backwards and forwards by a sliding hammer which delivers blows alternately on opposite sides of the test piece, at a point 3 inches above the base plate in which the test piece is embedded. The test piece, at the point of impact, is deflected  $\frac{3}{8}$  inch on either side of its mean position during each blow (see Fig. 48). There is no adjustment of the stress applied—the amount of deformation being independent of all the mechanical characteristics of the steel. The quantity measured by the test is the number of reversals of the test piece required to cause fracture. The Arnold test is, therefore, a form of reverse bend test, the angle through which the steel is bent being, however, less than that employed in the ordinary reverse bend test. The number of reversals required to cause fracture in the Arnold test is correspondingly greater. The standard adopted by Professor Arnold for his test is, that a properly ductile metal suitably free from brittleness will require over 300 reversals to cause fracture.

The Stanton test is of rather a different kind. In this test a square specimen carrying a notch is used—

the form of the test piece and the machine being described and illustrated in Appendix G. When making the test, the specimen is placed horizontally, and is stressed by receiving repeated blows from a falling hammer. Between each blow the test piece is rotated through  $180^\circ$ , so that the blow of the falling hammer is delivered

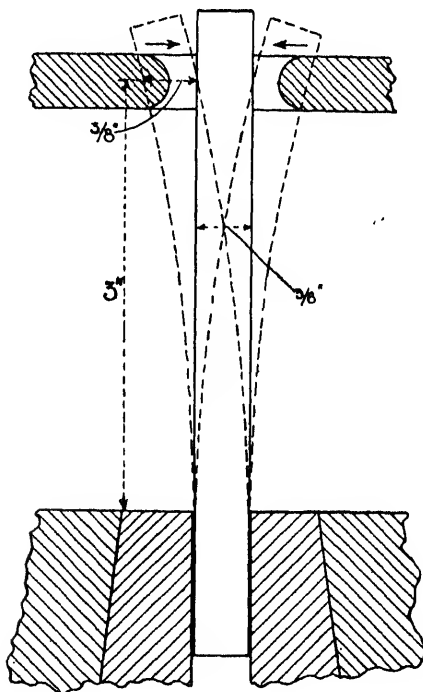

FIG. 48.—METHOD OF STRESSING IN THE ARNOLD ALTERNATING STRESS TEST.

alternately on two opposite faces of the test piece. As in the Arnold test, the quantity measured is the number of blows required to cause fracture. The actual stress applied to the test piece can be varied in this test by altering, either the height from which the hammer falls, or the weight of the hammer, or both. Even when this

is done, the mere measurement of the number of blows to cause fracture is arbitrary, and gives but little information regarding the fundamental mechanical properties of the steel. A typical application of the Stanton test was that a certain crankshaft for an aero engine was specified to withstand 5,000 blows (see also Appendix G).

The Upton Lewis test is rather similar to the Arnold test. A strip of steel is gripped at one end whilst the free end is bent backwards and forwards, the angle of bending being regulated by the amount of throw of an adjustable crank. It is claimed in this test, that the stress applied to the piece can be regulated according to the nature of the steel under test. This is quite true, but, as in the Arnold and Stanton tests, the actual quantity measured is decidedly vague—the number of reversals of stress to cause fracture being the indication of quality—since the stress can hardly be adjusted accurately.

**The Fatigue Range** of steel is a mechanical property more frequently determined nowadays than ever before. The tests required are not easy to carry out, and occupy a good deal of time. The determination consists of the discovery of that stress, either alternating, cyclical, or fluctuating, which, when applied to a steel for an indefinitely large number of applications, will not cause it to break. The "indefinitely large number of applications" has to be brought down to a concrete limit for testing purposes, and a very usual estimate of it is six million reversals of the stress. It is not usually possible to find out the fatigue range by one single experiment. It is necessary to test several samples of the steel—some loaded above and some loaded below the limiting stress—(those loaded above breaking at a comparatively small number of reversals, and those loaded below enduring more reversals than the decisive number—e.g., six millions). The results obtained from the various specimens may then be exhibited diagrammatically, as a curve of stress against reversals, the co-ordinates being the stress applied and the number of reversals endured. The curve



should become practically asymptotic, parallel to the axis of reversals, at the limiting or "fatigue" stress. A typical curve is shown in Fig. 49.

Various methods have been employed for the actual application of the stress to the test samples. The most widely honoured is probably that of Wöhler, in which the steel is tested as a rotating cantilever, the stress being applied by a weight, hung from a bearing attached at the free end. The fixed end is secured in a chuck, and the whole system is rotated at a suitable speed (e.g., 2,000 r.p.m.). A drawing of the arrangement with the

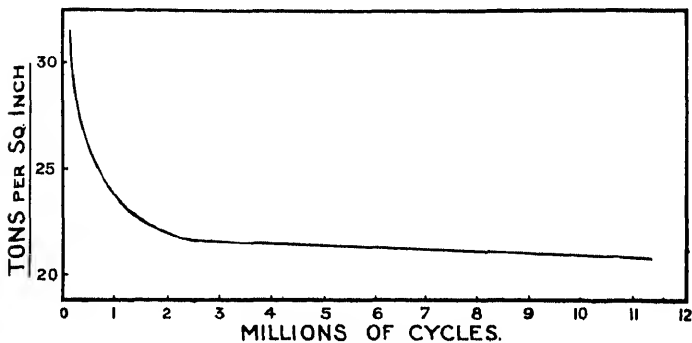

FIG. 49.—A TYPICAL CURVE OF THE OBSERVATIONS MADE IN A TRUE FATIGUE TEST.

usual form of test piece is shown in Fig. 50. It is necessary that the test specimen shall be shaped so that there is a very large radius at the shoulder. This precaution is absolutely essential, if the results obtained are to be at all reliable or regular.

A modification of the Wöhler method is that of Eden, Rose, and Cunningham, in which the specimen is stressed by the application of a uniform bending moment. In this arrangement, as in the Wöhler, the alternation of stress in the steel is secured by the rotation of the specimen. (A full description of the method and apparatus is given in the *Journ. Inst. Mech. Eng.*, 1911.) The method

of Eden, Rose, and Cunningham gives results which are quite in keeping with those obtained by the Wöhler method.

An entirely different type of machine is that designed

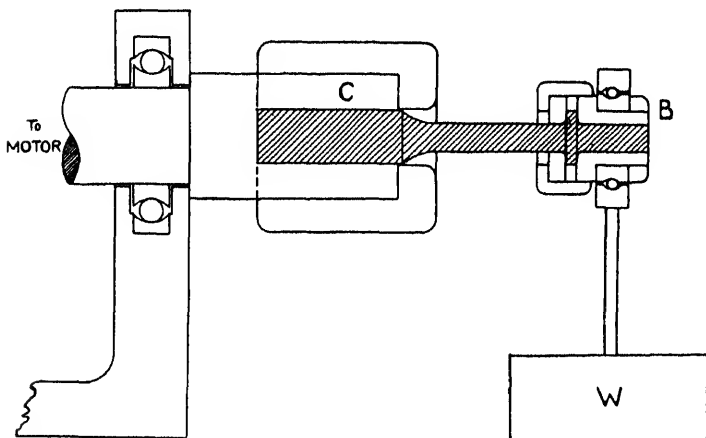

FIG. 50A.—DIAGRAMMATIC ILLUSTRATION OF THE ARRANGEMENT OF THE WÖHLER FATIGUE TESTING MACHINE.

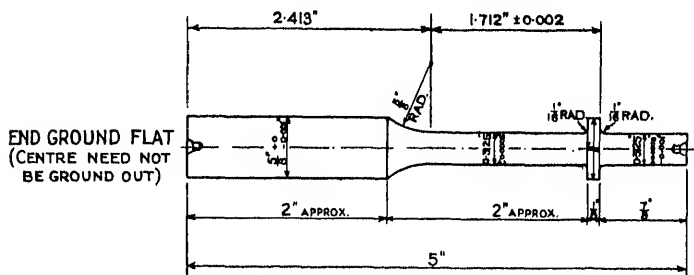

FIG. 50B.—STANDARD TEST PIECE FOR WÖHLER FATIGUE TEST.

and used by Dr. Haigh at the Royal Naval College, Greenwich. In this machine the steel is stressed, not by bending, but by direct tension and compression. The specimen is of approximately the same shape as an ordinary tensile test piece, and is secured in screwed

grips, one of which is moveable. The stress is applied to the test piece by electro-magnetic means, a suitably wound coil being placed round the moveable shackle. By various electrical adjustments, the rate of alternation of stress and the intensity of the tension and compression stresses can be altered as desired. (A complete description and sketch of the machine and test piece is given in Appendix H.) This method of testing is a highly useful one, and it is of great value to compare the results which it provides, with those given by the Wöhler method (see pp. 154 and 210).

Another method of testing the fatigue range of a steel which is of the greatest possible interest, and suggests the possibility of providing a method for the rapid determination of the fatigue range of a piece of steel, is that used by Strohmeyer (see Memorandum by Chief Engineer, Manchester Steam Users' Association, 1913). The principle utilised by Strohmeyer is described best in his own words. He says :—

The principle of the new test is based on the following consideration. There is practically no internal friction in perfectly elastic materials, such as steel. For instance, a vibrating tuning-fork will, if struck and placed in a vacuum, continue to vibrate for a long time, whereas if tuning-forks were made of brass or cast iron, which materials are slightly plastic, internal work would be done and the vibrations would soon die out, because the repeated strainings are associated with what might be called molecular friction. This friction will also occur in steel and other elastic materials, if the stresses to which they are subjected exceed their elastic limits ; and, as mechanical friction is converted into heat, it seemed probable that if a test piece were subjected to fatiguing stresses and if provisions were made for measuring any heat which might be generated, then it would be found that up to a certain limit, up to which the material was perfectly elastic, no heat would be generated, but if that limit were exceeded the resultant internal friction would produce heat, which might possibly be detected by

sensitive thermometers, and thus the limiting stress, or fatigue limit, would be found.

The means adopted for detecting and measuring the heat production was to surround the test piece with a loosely fitting sleeve of thick india-rubber, to pass a small stream of water along the annular space between the test piece and this tube, and to measure the difference of temperature between the inlet and outflow. When a difference of about  $0.01^{\circ}\text{C}$ . was noticed, the fatigue limit was supposed to have been reached, but the fatigue stresses were of course increased slightly, to confirm this indication. The difference of temperature between inlet and outflow would now be considerable, but would generally disappear again if the alternating stresses were reduced below the limit. Fortunately these calorimetrically determined fatigue limits were generally very clearly defined, and may be depended upon as being nearly correct.

Strohmeyer claims, and supports his claim by a considerable amount of experimental data, to have produced a method for the determination of the fatigue of a steel, which is both rapid and accurate.

Various tests have been proposed for the determination of the **Hardness** of a piece of steel. One of these has been mentioned above (the Brinell test), and the limitations of the method have been mentioned. Of the many other methods suggested, only one is in sufficiently wide and general use to need discussion. (Those interested in this question can find details of different proposals, by reference to the various papers on this subject given in the Bibliography in Appendix N.) This other method is that of the Shore Scleroscope. It is based upon the height of rebound of a pointed steel weight (the point being of diamond) which falls from a fixed height upon a clamped specimen. The specimen should be quite flat

for its use are carefully observed. It is found that the readings of the instrument are liable to be affected considerably by: (1) The rigidity of the support, table, etc., upon which the test is being carried out; (2) the mass of the specimen under test; (3) the condition of the surface which is being tested. In order, therefore, to give satisfactory results, it is essential that the instrument shall be used under standardised conditions. As it is almost impossible to guarantee that these conditions can be in any way standard for two different workers or workshops, it is useless to quote a definite scleroscopic hardness for any particular steel. (E.g., it is found that certain specifications for case-hardening steels call for a scleroscopic hardness of not less than 80 on a cemented and hardened surface. Without standardised conditions this requirement is valueless, as two pieces of steel of the same composition, depth of case, and heat treatment have been found to give results varying from 80 to 96.) To use the instrument successfully, it is evident that the same, or, if sufficiently massive, a similar support should always be used, and that the same size and shape of test piece should be employed. As an example of the conditions under which the method can be useful, case-hardened gears may be quoted. If it is desired to ascertain whether all the members of a batch of case-hardened gears have been hardened satisfactorily, the Shore Scleroscope can be employed, provided that the gears are all the same size, and also provided that one satisfactory sample can be taken as a standard. Comparative readings can thus be obtained and used. From what has been said, it is evident that, so far as is known, the Shore Scleroscope does not give an absolute measurement of the hardness of a piece of steel.

#### THE MECHANICAL PROPERTIES OF STEEL.

The above discussion has shown the methods which are usually employed to obtain information regarding the mechanical properties of steel. It seems desirable,

however, to discuss somewhat fully these various properties, in order to determine what they really are or mean, and in what way they can be used by the engineer. After carrying out a suitable selection of the tests enumerated above, the following information is available regarding the steel which has been tested :—

- (1) Elastic limit.
- (2) Yield-point.
- (3) Maximum stress.
- (4) Elongation.
- (5) Reduction of area.
- (6) Impact or notched bar value.
- (7) Brinell hardness.
- (8) Resistance to alternating stresses.
- (9) Fatigue range.

What do all these properties mean, and how are they to be used? It will be profitable to examine each one separately, and to endeavour to evaluate it in the sense of its usefulness to the engineer.

**Elastic Limit.**—The elastic limit of a piece of steel is usually determined by obtaining from the steel a diagram, showing the variations of strain produced in it by continuous increments of stress (see p. 90). The resulting stress/strain diagram is shown in its ideal form in Fig. 51. The elastic limit is defined by the British Engineering Standards Association as follows :—

The elastic limit is the point at which the extensions cease to be proportional to the loads. In a stress/strain diagram plotted to a large scale it is the point where the diagram ceases to be a straight line and becomes curved.

The point on the diagram in Fig. 51 which corresponds to the requirements of the definition is marked A, and the elastic limit of the steel is given by the stress co-ordinate corresponding to the point A. The Elastic Limit is obviously, by this definition, the Limit of Proportionality, and that is the sense in which the term

elastic limit is most usually employed in engineering. In the ideal diagram as given in Fig. 51, the elastic limit

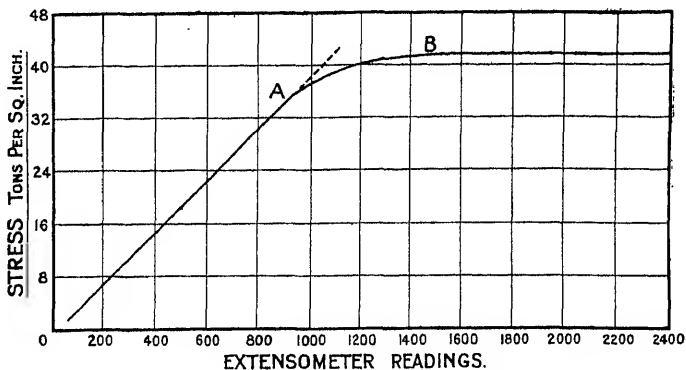

FIG. 51.—AN IDEAL STRESS/STRAIN CURVE OF STEEL.

is easy to see, but in actual practice it is frequently difficult to produce a diagram which even approximates to the ideal, except in certain soft steels. When hardened

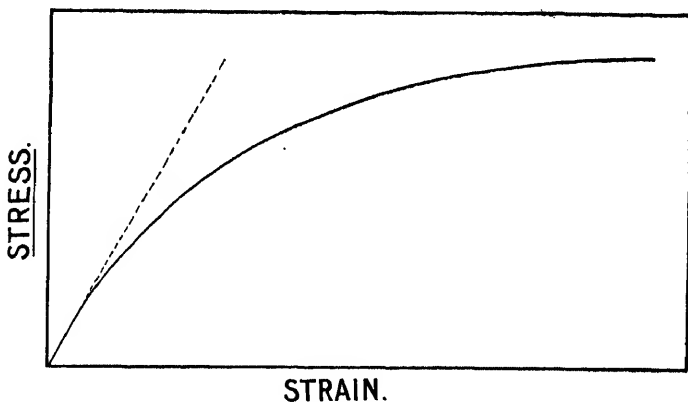

FIG. 52.—A STRESS/STRAIN CURVE AS OBTAINED FROM FULLY HARDENED STEELS.

gives no clearly cut point corresponding to the elastic limit. It is, therefore, very difficult to say what stress really corresponds to the elastic limit of such a steel, yet it is impossible to believe that the steel has no real elastic limit. It is of the greatest importance, therefore, that some good and reliable method of determining the elastic limit in such steels should be elaborated. That the ordinary method of determining it is unsatisfactory, is shown by the following experiments.

Take any steel which can be hardened fairly intensively—e.g., a high tensile case-hardening steel, or a 100-ton nickel chromium steel—and harden it out completely. Upon a sample of the fully hardened steel, make a stress/strain diagram, and find out the stress at which the curve departs from the range of proportionality, i.e., the apparent elastic limit. Some results which were obtained in an experiment of this kind are given in Table 11. In addition to the apparent elastic limit, the yield-point and the maximum stress are quoted. It can be seen that, according to this method of testing, the elastic limit of the steel is exceedingly low in comparison with the yield-point and the maximum stress.

TABLE 11.

THE LOW "ELASTIC LIMIT" OF HARDENED ALLOY STEEL.

Steel.	Elastic Limit, tons per sq. in.	Yield-point, tons per sq. in.	Max. Stress, tons per sq. in.
A	20·0	78·8	109·1
B	23·0	75·8	97·0
C	17·7	108·8	125·5
D	16·4	—	89·5

The steels represented in Table 11 are 100-ton air-hardening nickel chromium steels, and, therefore, can be tempered conveniently. Different specimens of each steel were tempered at temperatures varying from 200° C. to



500° C. The tempered specimens were then tested to give the apparent elastic limit, yield-point, and maximum stress. The results obtained are given in Table 12 and in Fig. 53.

It can be seen at once, from the results given in Table 12,

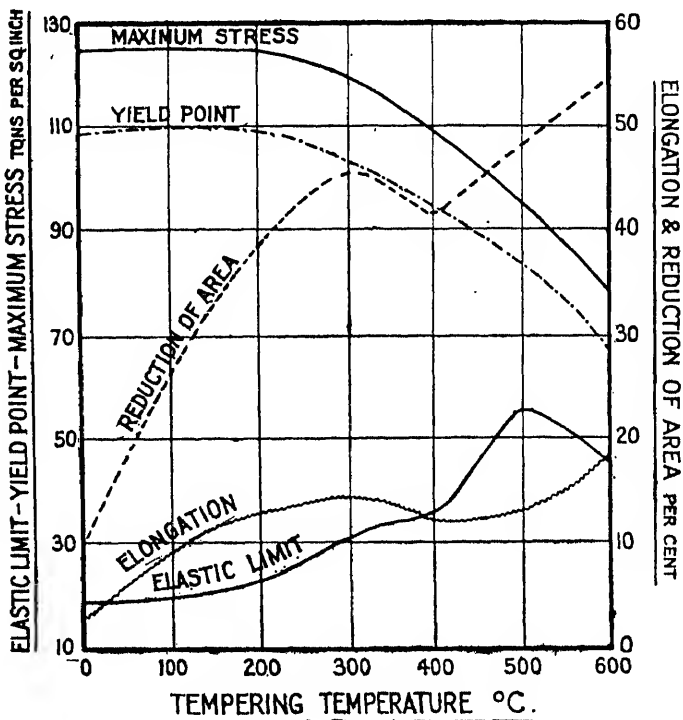

FIG. 53.—CURVES SHOWING THE EFFECT OF TEMPERING UPON THE MECHANICAL PROPERTIES OF STEEL, NOTABLY THE "ELASTIC LIMIT."

that although the operation of tempering the steel has had the usual effect upon the ultimate strength and the yield-point, i.e., has lowered them distinctly and regularly, the effect of tempering upon the elastic limit has been to raise it. It is found that whilst the maximum stress

has been lowered from, say, 100 tons per sq. in., to 80 tons per sq. in., the elastic limit has been raised from, say, 20 tons per sq. in. to 45 tons per sq. in. If the elastic limit, as recorded, represents really the failing-point of the steel, the only interpretation of this result would be

TABLE 12.

THE EFFECT OF TEMPERING UPON THE "ELASTIC LIMIT" OF HARDENED ALLOY STEEL.

Steel.	Tempering, Temperature °C.	Elastic Limit, tons per sq. in.	Yield-point, tons per sq. in.	Max. Stress, tons per sq. in.
A	—	20·0	78·8	109·1
A	200	36·2	77·5	101·2
A	400	53·3	80·5	97·9
A	500	51·7	71·3	82·4
B	—	22·0	75·8	97·0
B	200	25·6	74·0	94·0
B	300	27·8	74·0	93·4
B	400	36·4	74·0	90·8
B	500	45·3	60·0	72·7
C	—	17·7	108·8	125·5
C	200	22·8	109·0	124·0
C	300	30·3	103·5	119·0
C	450	35·4	96·0	109·0
C	500	55·7	83·5	96·5
D	—	16·4	—	89·5
D	200	24·2	—	90·4
D	300	30·6	—	87·9
D	400	36·8	—	88·1
D	500	49·3	—	81·5

that a steel of 100 tons strength can only withstand in practice, without plastic deformation, rather less than one-half the stress that can be endured by a steel with a strength of only 80 tons. Test results such as those given in Table 12 can be repeated regularly; in fact, they are always obtained when steels of the kind which harden drastically are tested for the apparent elastic limit. It

seems evident, therefore, that there is something wrong, and that what is called the elastic limit in an ordinary test, is not the true elastic limit of the steel at all.

One probable explanation of this peculiarity may be that, in steels which are hardened, a good deal of internal stress is set up due to contraction and volume changes during the actual operations of hardening (see Chapter III, p. 74). That such strains do exist, may be shown quite convincingly by the distortion which very often occurs during the quenching of steel. It may also be shown by a simple experiment, which consists of making measurements of the length of a bar of steel, before and after quenching. When a bar of steel is hardened it becomes shorter. If the diameter of the bar is then reduced by machining away successive layers, and measurements are made of the length of the bar after each layer has been removed, it is found that the bar gradually lengthens. Evidently, there must be some internal stress in the steel which is producing this gradual and steady alteration of dimension. It is also evident and reasonable to believe that some original strain was present in the steel, and that it is gradually relieved by the machining away of the outer layer. Each successive removal of material relieves the stress still further and allows the further lengthening of the bar. Since the bar lengthens during the process of turning, it is reasonable to assume that the strain in the steel produced by hardening was a compression strain.

Assuming, therefore (and in all probability making a very correct assumption), that in a piece of hardened steel the material is definitely in a state of strain (probably in compression), it is not surprising that the ordinary observations of a tensile test show some evidence of the existence of this strain.<sup>1</sup> When the steel is put in the testing machine and is strained, the tensile stress put upon the steel probably has the same effect in releasing the internal strain, as has the removal by machining of

<sup>1</sup> The author gives this theory as being the one most usually accepted, but does not thereby commit himself to any support of it.

described above. The earlier applications of stress to the hardened steel have, therefore, two effects. First, they are neutralising and removing the internal strain produced during hardening, and, secondly, they are producing an elastic strain in the steel. Any observation made upon an extensometer is, therefore, almost sure to represent the resultant of the two effects. It is reasonable to assume that, in the majority of instances, these two effects do not suffer the large variation in value such as would be indicated by the point on the stress/strain curve, and known as the "elastic limit," at the same stress. There must, therefore, be some definite change of slope in the extensometer curve at the point at which the internal stress is removed, if this occurs at a lower stress than the elastic limit. It is reasonable to believe, therefore, that the change of slope in the stress/strain diagram, which is usually read as being the elastic limit, is in reality not the elastic limit at all, but something which is neither a fundamental property of the steel, nor a property of any value to the engineer, but is associated with the removal of hardening strains from the steel. The explanation given in the above paragraph fits in satisfactorily with the results obtained in the series of tests on tempered steels quoted above. The operation of tempering possibly has two effects. In the first instance it may be assumed to lower the *true* elastic limit, and in the second place it may be assumed to have some effect in removing the internal strains locked up in the steel by the process of hardening. The magnitude of the internal strains remaining in the steel will be smaller as the tempering temperature becomes higher, and it is reasonable to assume that, at some pre-ordained temperature, these strains will have been removed completely. The curve, therefore, of "elastic limit" in Fig. 53 represents really two curves which cross one another. The first curve indicates the gradual removal of the internal strains during tempering, and the consequent raising of the

apparent "elastic limit" or "limit of proportionality." The value of the latter stress apparently, therefore, rises with the temperature. The second curve represents the fall of the true elastic limit with a rise in the tempering temperature of the steel. These two curves evidently

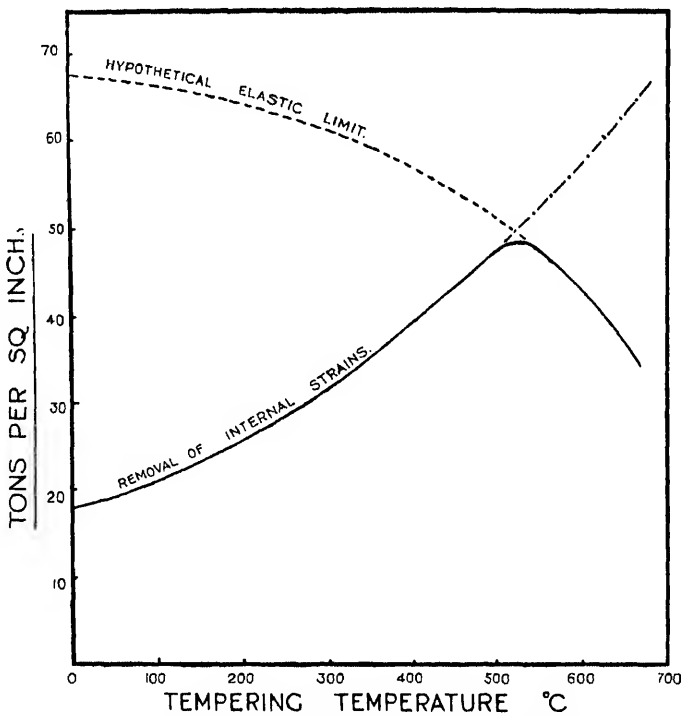

FIG. 54.—HYPOTHETICAL CURVES SHOWING TWO EFFECTS OF TEMPERING A STEEL, NAMELY, LOWERING OF TRUE ELASTIC LIMIT AND REMOVAL OF INTERNAL STRAINS.

cross at a temperature of about 400° to 450° C., and since the extensometer only shows the change which occurs at the lower stress (whichever change this may be, either the complete removal of internal strain or the true limit of elasticity), the two curves are not shown in full, but

only the lower half of each curve fused into one. The first and rising part of the curve in Fig. 53 represents the removal of internal strains, and the second or falling part represents the change of the true elastic limit. In Fig. 54 the two curves (hypothetical) are shown for their full extent, the thickened part being the actual observed curve corresponding to that in Fig. 53.

The different forms of stress/strain curve obtained with steels fully hardened, and those tempered above the temperature at which the two curves suggested above

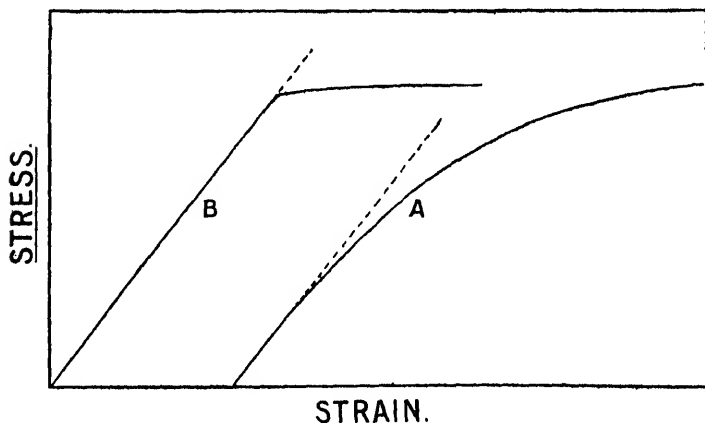

FIG. 55.—STRESS/STRAIN CURVES OF THE SAME ALLOY STEEL: (A) FULLY HARDENED, (B) AFTER TEMPERING.

cross (e.g., 450° C.) are shown in Fig. 55. It can be seen that, whereas in the hardened steel the change of slope, A, in the curve is quite indefinite, in the tempered steel there is a fairly definite change of slope, B, which allows of a reasonably accurate determination of the elastic limit. It is reasonable, therefore, to assume that it is only in the latter case that there is any kind of meaning to be attached to the "elastic limit" determination as made in an ordinary tensile test.

The vagueness of the "elastic limit" value obtained

from a tensile test is not confined to quenched steel, but is met with to almost the same extent in cold worked steels. This will be referred to again in the section dealing with Cold Worked Steels.

Bearing in mind the points enumerated above, it becomes of interest to inquire what is the *real* elastic limit of a piece of steel. A discussion of this point involves the prior discussion of the fatigue range of a steel, and is, therefore, deferred until after that property has been considered.

**Yield-point.**—The yield-point of a piece of steel has been defined by the British Engineering Standards Association as follows:—

The yield-point shall be the load per square inch at which, when the load is increased at a moderately fast rate, there is a distinct drop of the testing machine lever, or, in hydraulic machines, of the gauge finger, or at which a distinctly visible increase occurs in the distance between the gauge points on the test piece observed by using dividers.

From the definition it is clear that there is some considerable doubt as to the real nature of the yield-point. What is being referred to in the definitions is shown diagrammatically in the stress/strain curve in Fig. 51, as the point B. For steels which give a stress/strain curve similar to that shown in Fig. 51 or in Fig. 55B, there is some likelihood that the yield-point may be observed within fairly reasonable and close limits, but unless the stress/strain curve is of the type shown in these curves, and particularly if it happens to be of the type shown in Fig. 52, the taking of a reading for the yield-point is a very doubtful proceeding. It is a matter of some considerable doubt as to whether the yield-point can be really determined at all in steels which give a curve like that in Fig. 52.

The yield-point indicates that, at a certain particular stress, the steel has undergone some amount of plastic

flow, and has suffered a certain degree of permanent deformation. It, therefore, indicates a stress slightly higher than the elastic limit of the material, and also represents, therefore, the absolute limit of stress to which the steel can be loaded without being seriously distorted. This information would be of great value to the engineer, provided that it could be obtained with ease and regularity. Unfortunately, however, the yield-point of steel cannot be obtained either easily or in a really consistent manner, as is readily demonstrated by comparing the results obtained by a number of different observers on the same steel. The personal element in testing is nowhere more clearly shown than in the making of yield-point determinations. The definition of the property shows that this uncertainty is probable.

As a means of avoiding some of the more serious objections to the use of the yield-point as ordinarily determined, proposals have been made that it should be replaced in ordinary routine testing by what is known as the "proof stress." An inspection of a few specifications for steel will readily prove the fact that the yield-point is required always to be not less than a certain stipulated stress per square inch. If it is greater than the stipulated stress, no objection is raised, but it must not be less. It is much easier to determine whether the yield-point is above a certain figure, than to make a correct determination of the actual stress corresponding to the yield-point. All that need be done is to load the test piece, so that it is stressed to an amount equal to the stipulated minimum yield-point, allow the load to operate for a fixed time, remove the load, and measure the test piece in order to determine whether any permanent stretching has occurred. If the steel has not stretched, then the yield-point must be higher than the stress applied, and if, on the other hand, the steel has stretched permanently more than a very small amount, then the yield-point of the steel is lower than the stress put upon the steel. An amount of stretch equal to  $1/200$



of the gauge length is usually taken as the most satisfactory criterion, so that a steel which, on the application of the "proof stress," does not stretch more than  $1/200$  of the gauge length, has passed the test satisfactorily, and the yield-point is higher than the proof stress, and vice versa. For routine testing the use of the proof stress, as opposed to the determination of the yield-point, is to be strongly recommended.

**Maximum Stress.**—This property is quite simple to understand and to appreciate. It is difficult, however, to see what possible use it can be, *per se*, to the engineer. It tells him the load at which the steel in a part will break, but he is not designing parts to break, but to withstand the loads which are put upon them. He cannot even use the maximum stress of the steel, by designing on slightly less than this stress, and feeling confident that the part will, therefore, withstand all the stresses which he wishes to impose, because the steel is not rigid or even elastic at all stresses less than the maximum stress, and undergoes considerable distortion of a permanent character, when submitted to a stress greater than the yield-point. Engineering constructions are not supposed to submit to any permanent distortion when in use, since stability and permanence are the two essential properties of such structures. Since there must be no distortion, the yield-point of the steel represents the utmost limit of stress to which it can be exposed in actual use, and the maximum stress of a steel is a property quite independent of the yield-point. If the maximum stress has no designing value, what is the use of it to the engineer? So far as can be seen, it is useful only in consequence of the fact that the maximum stress has been used so much in the past, that a knowledge of its value is translated by experience into terms of other properties which are of use to the engineer. The value of the maximum stress implies in the mind of the engineer a statement of the elastic limit, the yield-point, or the fatigue range, or whatever property of the steel is being

used by the designer in his assumption of uniformity, the engineer is let down badly by his assumption, but these occasions are much fewer than those in which his faith is upheld, and as the disappointments appear to occur with a certain amount of regularity, they become registered in his experience, and may be predicted with the same regularity as those experiences in which his expectation or his faith is upheld. So far as can be seen, this translation of the ultimate strength, by experience, into other properties (of use to the designer), is the only way in which the ultimate strength can be regarded as of value, but it is probably of sufficient value to make the determination of the maximum stress of a steel worth while.

**Elongation and Reduction of Area.**—The next two properties, namely the elongation per cent. and the reduction of area per cent., are always obtained, in a tensile test, by making measurements of the dimensions of the test piece before and after fracture. They are properties upon which a great deal of stress is laid by many engineers. In general they are very dependent variables, as the values for elongation and reduction of area which may be obtained from a good and satisfactory piece of steel, depend almost entirely upon the maximum strength (yield-point, etc.) of the steel. (They also depend to some extent upon the nature of the steel, i.e., as to whether the steel is forged, or cast, or cold rolled, and the above remarks may be taken to apply to steel of any one definite class.) It is unreasonable to expect that a steel will give the same value of elongation and reduction of area, if its maximum strength is 75 tons, as if its maximum strength were 45 tons. With the former steel the elongation might be considered to be good if it were 12 per cent., whilst in the latter case it would probably be good, only if it were more than 20 per cent. The elongation and reduction of area per cent. vary more or less inversely as the maximum strength of the steel, and the values obtained for these properties

on a piece of steel must be regarded accordingly (see the curves in Fig. 69).

It is usually found to be true that the elongation per cent. and the reduction of area per cent. on a piece of steel, are values which are to some extent associated, i.e., a steel giving a high value for the elongation usually gives also a high value for the reduction of area. There is, however, no definite relationship, and it would be quite wrong to assume that a knowledge of the value for elongation would provide also a knowledge of the value of the reduction of area. The ratio of elongation to reduction of area is different, even on average values, between one class of steel and another. The usual ratio for forgings is quite different from that for castings. It is generally found, too, that the value, which really is the more susceptible and is the better criterion of ductility, is the reduction of area and not the elongation per cent. Whatever empirical relationship there is between the elongation and the reduction of area only holds good if certain conventions are observed in respect to the shape of the test piece. These dimensions have no influence upon the value obtained for the reduction of area, but they do affect the elongation value. That this must be so can be made clear by a consideration of the way in which a test piece elongates during a test. The elongation produced in the test piece is not uniform over the whole extent of the gauge length. It is more or less uniform over the greatest part of the length, but, at a certain point, i.e., near to the point of final fracture, the test piece elongates much more than it does on the average of the whole length. This "neck" develops by excessive elongation and reduction of area, and ultimately locates the fracture of the steel. Obviously, this "neck" represents a considerable proportion of the total extension, which forms the elongation of the test piece as a whole. If the extension in the "neck" be  $x$  inches, and the extension in the remainder of the length be  $y$  inches, then the total extension is  $x + y$  inches, and the pro-

portion of the local extension in the " neck " to the total is  $\frac{x}{x+y}$ . Evidently, this fraction becomes greater as  $y$  becomes smaller, and evidently, also, the elongation per cent. becomes greater as the value of this fraction increases. The fraction becomes greater as  $y$  becomes less, and  $y$  is decreased by shortening the gauge length, since the value of  $y$  is proportional to the gauge length (roughly). Consequently, therefore, if the diameter of the test sample be fixed, the actual value of the elongation, roughly, varies inversely as the length of the test piece. The dimensions of one of the commonest standard test pieces, in use in this country, are 0.564 inches for the diameter and 2 inches for the gauge length. The relationship between these two dimensions is given by the formula

$$L = 4\sqrt{A} \quad \text{or} \quad \frac{L^2}{A} = 16 \text{ (a constant)} \quad . \quad . \quad (i)$$

where  $L$  is the gauge length of the specimen gauge, and  $A$  is the cross sectional area of the cylindrical test piece. Expressed in terms of the diameter the formula becomes :

$$\begin{aligned} L &= 4\sqrt{\frac{\pi d^2}{4}} \\ &= 2d\sqrt{\pi} \\ &= 3.54 d \quad . \quad . \quad . \quad . \quad . \quad . \quad (ii) \end{aligned}$$

It is found that, if the relationship of gauge length to diameter expressed by the relationship (i) or (ii) above is observed, no matter what the actual dimensions of the test piece, the values obtained for the elongation and the reduction of area are comparative. This does not mean that only one size and shape of test piece shall be employed, but that the length upon which the elongation per cent. is calculated shall be equal to four times the square root of the area of the test piece, or shall be equal to 3.54 times its diameter. If this relationship is observed, then the values for the elongation per cent. given on different

sizes of test pieces are perfectly comparable. If this relationship is not observed, however, the results are not directly comparable but require conversion.

Another factor which enters into the values obtained for the elongation per cent. and the reduction of area per cent., is of considerable importance in connection with forged steels. In tests upon such steels, totally different results are obtained when the axis of the test piece is parallel to the direction in which the steel has been elongated during forging, from those obtained when the axis of the test piece is perpendicular to this direction.

The reason for this difference is given in Chapter II (p. 29), but the effect can be clearly shown by the test figures given in Table 13, the results being taken from tests made on specimens cut from different parts of the same aero engine crankshaft.

TABLE 13.

THE EFFECT OF DIRECTION OF FIBRE UPON DUCTILITY OF STEEL.

Direction of Axis of Test Piece.	Max. Stress, tons per sq. in.	Elongation %.	Reduction of Area %.
Longitudinal ..	61·8	20·6	56·8
Transverse ..	57·0	3·3	6·0
Longitudinal ..	62·5	19·0	43·4
Transverse ..	59·7	8·0	19·6

In the great majority of tests, the results for elongation and reduction of area quoted for steel, are those which should be obtained upon longitudinal test pieces, that is, test pieces cut with their axes parallel to the direction in which the steel has been drawn out during forging. Occasionally, it is necessary to test samples cut transversely (as in gun forgings), but, in these cases, the conditions are usually specifically stated, and the results expected are necessarily lower than for longitudinal test pieces.

of the elongation per cent. is of little value. This material is steel sheet, and it has been shown quite clearly that the value obtained for the elongation per cent. on such material is considerably affected by the gauge of the sheet. Even though the sheets are rolled from the same ingot of steel, and are in exactly the same condition of heat treatment, e.g., 'normalised', the values for the elongation per cent. obtained from a 12 gauge sheet will be notably different from those obtained from an 18 gauge sheet, the differences being sufficiently great to make it impossible to specify any particular value of elongation which must be given by steel sheet, unless the specification is restricted to one gauge. When testing sheet, therefore, the elongation measurement should be neglected, and the information usually obtained from this factor taken from the bend tests.

The real worth, to the engineer, of the values obtained for the elongation and reduction of area per cent. is almost as elusive as is that of the maximum stress. The evaluation of all these three properties presents the same difficulties. The elongation and reduction of area are regarded usually as a measure of the ductility of the steel, and it may be conceded at once that these two pieces of information do give a very reasonable indication of ductility. It is by no means easy, however, to see in what way the engineer should regard the property of ductility when selecting a steel for any particular job. As stated in the section dealing with maximum stress, engineering structures are intended to be rigid, and if they are rigid they obviously are not called upon to flow, and consequently the ease with which a steel does flow (which is really what is meant by ductility) seems to be of little importance to the engineer. There are certain conditions, however, under which the capacity for flow in a steel may be of some use. It is well known (see Appendix A) that in an engineering structure all the parts are not stressed to the same extent, and it is also

known that, in any one part, there may be a very unequal distribution of stress, in consequence of the presence of a relatively sharp corner at some point or other. If a steel is absolutely rigid and not capable of flowing at all, the concentration of stress which occurs at or near to the sharp corner, may result in the fracture of the steel, since the metal may be stressed beyond its yield-point. If, however, the steel is reasonably ductile, the flow of the metal at this particular point may be sufficient to avert failure. The steel distorts and flows in such a way as increases the radius and does away with the sharp corner. The change of shape lessens the concentration of stress and releases the strain on the steel, thereby preventing the fracture of the steel, which otherwise might occur. Under circumstances of this nature, which are far more common than is imagined, it is, evidently, desirable that the steel which is used should possess a reasonably good ductility, which means a suitably high value of elongation and reduction of area. Nevertheless, the amount of flow, under the conditions which have been described, is not likely to be very great, taking the part as a whole, though in the small element which naturally distorts, the change of shape may be quite considerable.

The elongation and reduction of area may be of some further value in the direction of indicating to the engineer that the steel which he is using has been manufactured properly. It is difficult to express in actual terms what really composes the quality of a steel, but it is improbable that any maker or any user of steel would deliberately choose to use a steel which possessed only low values of the ductility indicators. Nevertheless, the actual figures of elongation per cent. and reduction of area per cent. are, as was stated above, strictly relative, and they can only be taken into account in conjunction with the maximum stress of the steel under consideration. Similarly, it is hardly possible to say that any particular value of elongation or reduction of area is a safe value, or is one which will guarantee the life of a part. This must

be obvious, when it is considered that the ductility factors are called into play in engineering parts and structures only under very special conditions and circumstances.

**Impact or Notched Bar Value.**—As stated in the discussion on the methods of making the impact test, the principal factor is the presence, and the next most important is the form, of the notch in the steel. The values obtained from specimens similarly notched are practically the same, whether the load be applied suddenly or gradually. The rate of making the test is practically of no importance. It is, therefore, desirable that in place of the terms “impact value” and “impact test,” “notched bar value” and “notched bar test” should be substituted. By using these titles in place of those customarily employed, a more accurate appreciation of the nature of the test is obtained, as the test has nothing to do with impact, in the sense usually accepted of high speed or shock loading. The notched bar test really represents, so far as can be seen, the capacity which a steel possesses to resist the formation or the growth of a crack. If a stress/strain diagram be drawn to represent what happens during the carrying out of the notched bar test, it will be found that the greatest part of the energy absorbed, when testing a tough steel, is taken up in extending the crack which has once been formed. Two typical diagrams of this nature are shown in Fig. 56, the diagrams having been obtained upon two pieces of steel which have exactly the same physical properties, in all respects, as shown in the tensile test, but which vary very considerably as regards notched bar value. The notched bar value of the first steel was about 60 ft.-lb. and that of the second about 8 ft.-lb. A comparison of the two diagrams in Fig. 56 shows that the amount of work required to produce the crack (the total work expended in the test being shown by the shaded area) is the same for each steel, and is relatively small, but that the amount of work absorbed in spreading the crack through the test piece



is very different. This suggests that the notched bar test largely indicates the resistance which a steel opposes to the growth of a crack that once has started in it. The work absorbed during the second half of the impact test, i.e., during the extension of the crack, is very largely used up in distorting the metal. In steels which have a very low impact value, the distortion which occurs during the break is practically nil, whilst, in steels having a high impact value, the specimens have changed shape very much indeed, so that the crack is really extended by the tearing apart of the metal. In reality, it appears, therefore, as though the steel, at the moment that a crack

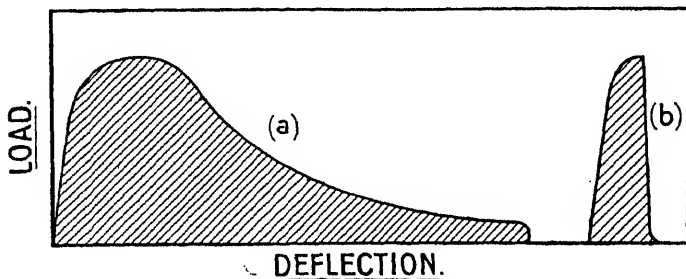

FIG. 56.—STRESS/STRAIN CURVES OF TOUGH (a) AND BRITTLE (b) STEELS TESTED IN IMPACT.

is started, has to make a decision—either to distort or not to distort. If it decides to distort, then the extension of the crack requires the expenditure of a great deal of energy. If it decides not to distort, then the crack can be propagated very easily indeed.

The notched bar value of a steel, like the elongation and reduction of area, is not an entirely independent function. For steels which are in their best condition as regards notched bar value, it is found that the value which is given is, approximately, inversely proportional to the maximum strength of the steel. For instance, a steel of 40 tons maximum strength may be considered

50 ft.-lb., whilst a steel of 100 tons per square inch would be considered satisfactory if the notched bar value were over 15 ft.-lb. (This might be expected from what has been said regarding distortion during the notched bar test. A 40-ton steel is capable of greater distortion without fracture than is a 100-ton steel.) The notched bar value, therefore, of a steel, must not be regarded as an absolute figure. Its actual magnitude is only of relative significance, and is of no value apart from the ultimate strength of the steel on which the value has been obtained. The notched bar value is also affected considerably by the type of the steel which is under test. If three steels, e.g., a plain carbon steel, a nickel chromium steel, and a high speed steel, are all heat treated to give the same ultimate strength, the notched bar value of these three steels will be by no means identical. Probably, the nickel chromium steel would give the highest value, the plain carbon steel the next highest, whilst the high speed steel would probably give a comparatively low value. The nature of the steel must always be taken into account, when the notched bar value given by it is being considered. This fact makes it impossible to compare two steels exactly upon the basis of the absolute magnitude of their notched bar value. This means that if two steels are suggested as alternatives for any particular piece of work, it is not practicable to select one of them as more suitable on the grounds that it gives a higher notched bar value than the other, unless the two steels happen to be of the same type, and possess the same ultimate strength.

The great value of the notched bar test is, that it gives the most useful indication as to whether or not a steel has been heat treated in the best possible manner. (The methods of heat treatment which should be employed in order to give really satisfactory values in the notched bar test, are discussed in the chapters on Heat Treatment, and Alloy Steels.) It may be assumed as correct that a steel which has been perfectly heat treated will

have a high notched bar value, whilst a steel which has not been properly heat treated will have a low notched bar value. It is usually found that the notched bar value of a steel is either high or low, intermediate values being, comparatively, rarely obtained. This fact enables the engineer to utilise the test values fairly easily. In the best modern specifications for steel, notched bar tests are always quoted, and a figure is given with which the steel must comply if it is to be accepted. Occasionally, a notched bar value is obtained which is 1 or 2 ft.-lb. lower than that specified, and there is a tendency amongst engineers to attach a good deal of importance to this fact. Such a tendency appears really to be wrong, for the reasons mentioned above, namely, that if a steel has not been heat treated properly it will give only a low notched bar value, and if the steel gives a value equal or near to the specification value, it can be considered to be quite satisfactory. This misconception on the part of engineers probably arises from the fact that they look upon the notched bar value as a designing value, on the same plane as the maximum strength or elastic limit. This view is difficult to uphold, and is better replaced by the view given above, namely, that the notched bar test is an indication that the material has been properly heat treated. (The importance of holding the view which is advocated becomes even more plain, if the comparative difficulty of machining the root of the notch is considered, and it is remembered that a small variation in the radius of the notch may have a distinct effect upon the result.)

The notched bar value of a steel is affected, in the same way that the elongation and reduction of area per cent. are affected, by the relation of the axis of the test piece to the direction in which the steel has been forged. (This point is discussed in Chapter II, p. 30.) If the axis of the test piece is parallel to the direction in which the steel has been drawn out during forging, the notched bar value will be much higher than it will be if the axis

of the test piece is perpendicular to the direction of drawing out. This effect is shown very clearly in the diagram given in Fig. 14. In this diagram are plotted the results of a series of tests which have been carried out upon various samples of the same piece of steel, heat treated in the same way, the only difference between the various samples being the angle at which the axis of the test piece is inclined to the direction in which the steel was drawn out during forging. All the tests quoted in this book have been made on samples selected so that the axis of the test piece is parallel to the direction of drawing out of the steel, unless the contrary is stated explicitly.

**Fatigue Range.**—The fatigue range of a steel is a property which is fairly easy to understand. It represents the range of stress within which a steel may be loaded for an indefinite period without failure, the stresses being understood to be alternating or cyclical. It also indicates that if the range of cyclical stress which is applied to the steel is greater than is allowed by the fatigue range, then fracture of the steel will ensue after a comparatively small number of cycles. It might be expected that the plus limit of the fatigue range of the steel would be represented by the elastic limit in tension, and the minus limit of the fatigue range would be represented by the elastic limit in compression. It may be assumed for purposes of argument that the elastic limits in tension and in compression, for any piece of steel, are the same, and, therefore, it would be expected that the fatigue range of the steel would be represented by twice the elastic limit, i.e., that the steel could be stressed in tension and in compression to the elastic limit, each way, with safety. In order to make it perfectly clear what is meant by the fatigue range, a concrete example may be quoted. A series of specimens of steel all of the same tensile strength were tested, and when the results were plotted suitably (as shown in Fig. 49), it was found that the steel could be stressed, alternately, in tension to a

value of 32 tons per square inch, and in compression to the same value. The fatigue range of this steel is therefore represented as being  $\pm 32$  tons per square inch. The actual range of stress applied to the steel is, therefore, 64 tons per square inch, half of this being in tension, and half being in compression. In the discussion on the fatigue range it will always be assumed that the *range* represents the sum of the tension and compression stresses. The limit of stress which can be applied in tension will be spoken of as the **plus fatigue stress**, whilst the limit on the compression side will be spoken of as the **minus fatigue stress**. In the example in question the fatigue range is 64 tons, the plus fatigue stress is 32 tons, and the minus fatigue stress is 32 tons.

The assumption that the plus fatigue stress would be equal to the elastic limit appears to be reasonable from first principles, since the conception of the elastic limit is that it is the greatest stress which the steel can endure without undergoing permanent deformation or plastic flow, and it is difficult to see how a steel can really be fractured at all unless it undergoes this type of deformation. So long as the steel is simply being stressed elastically the fracture of the part might appear to be inconceivable. When tested experimentally, this assumption is shown to be incorrect. If a piece of steel is tested in tension, and the elastic limit is observed, and then another piece of the same steel is tested in order to determine the fatigue range (with equal plus and minus stresses), it is found that there is no definite or regular relationship whatever between the static elastic limit and the plus fatigue stress. For the moment it is assumed that the elastic limit, as determined in the tensile test, has been determined with accuracy, and that the value obtained does really represent the static elastic limit of the material. If this assumption is correct it is evident that a steel possesses two elastic limits, the first of them representing the elastic limit when the steel is exposed to static stresses, and the other representing the elastic

limit when the steel is exposed to alternating stresses. It has been suggested that the elastic limit of the steel, as shown in the static test, should be called the apparent elastic limit, whilst the elastic limit, as shown in the fatigue test, i.e., the elastic limit under dynamic stresses, should be called the natural elastic limit of the steel. The difference between these two values is shown clearly by the figures given in Table 47, p. 209, which represent the results of tests carried out upon various sets of specimens of 100 ton air hardening nickel chromium steel which had been tempered at different temperatures. The first set of results shows the elastic limit, as given by the tensile test, and the second set of results shows the fatigue range of the steel. The discrepancy between the two results is obvious, even in those cases where the elastic limit, as determined in tension, may be considered to have been satisfactorily observed, in consequence of the high tempering temperature, to which the steel has been subjected, having removed the quenching strains which tend to produce inaccurate results (see p. 112).

The fatigue range of a piece of steel is not necessarily constant, but depends to some extent upon the proportions of the plus and minus stresses. If the plus and minus stresses are equal, then the fatigue range may be considered to be an absolute function of the steel, and to have a definite value. If, on the other hand, the plus and minus stresses are not equal, the fatigue range of the steel has a different value from that which it possesses when the stresses are equal. In the concrete example taken above, the fatigue range was 64 tons per square inch, the plus fatigue stress and the minus fatigue stress each being 32 tons per square inch. If the plus fatigue stress were raised to 36 tons per square inch, it is not safe to assume that the fatigue range would remain at 64 tons per square inch, the minus fatigue stress becoming 28 tons per square inch in order to produce this effect. The minus fatigue stress would certainly be less than 28 tons per square inch if the plus fatigue stress were

raised to 36 tons per square inch, and the fatigue range of the steel would be less than 64 tons per square inch. It is possible to raise the plus fatigue stress of a steel very considerably, provided all the time that the minus fatigue stress is being lowered, and also that the minus fatigue stress, applied to the steel, is lowered more than

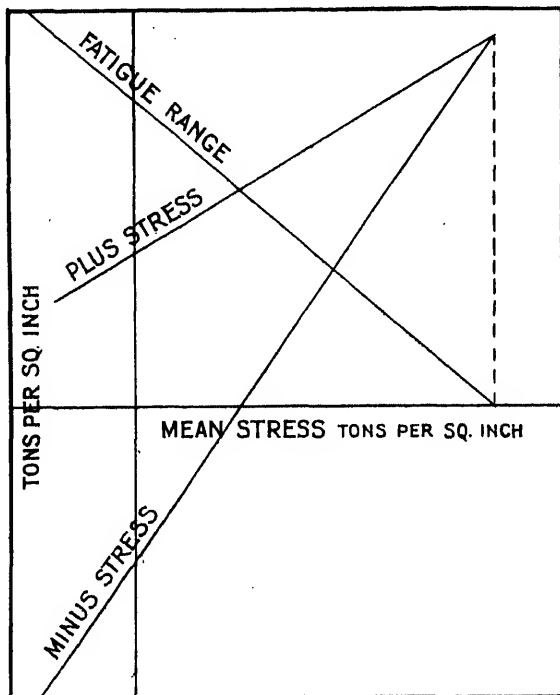

FIG. 57.—DIAGRAM SHOWING THE ALTERATION OF THE FATIGUE RANGE OF A STEEL RESULTING FROM CHANGES IN THE VALUE OF THE PLUS FATIGUE STRESS

the plus fatigue stress is raised, so that the fatigue range is lessened. If the plus fatigue stress is raised considerably, then the fatigue range becomes comparatively small, as is shown in the diagram given in Fig. 57. This subject has not yet been worked out thoroughly, though

it is one deserving the greatest possible attention, since, in quite a large number of engineering parts, the stresses are not static but dynamic, and are not purely alternating but merely fluctuating. For instance, in a railway bridge the weight of the structure itself imposes a certain steady stress upon the steel in it. When a train crosses the bridge this stress is not released but is increased. The steel in the bridge is, therefore, stressed under a fluctuating load, which varies from possibly 4 tons per square inch to 6 tons per square inch. A similar example is the case of a valve spring. This spring is always stressed in torsion to a certain value, even when the engine is resting. When it is running, the compression of the spring increases the stress in the steel, which is stressed under a load which fluctuates from, say, 25 tons per square inch to 40 tons per square inch. Needless to say, the process of increasing the plus fatigue *stress* in this way by decreasing the fatigue *range*, has its limits. It is not possible to allow the plus fatigue stress to exceed the yield point of the steel without causing the material to stretch. This stretching usually puts a limit upon the practical possibilities of the proceeding.

The alteration of the fatigue range, by altering the conditions of loading, makes it still more difficult to account for all the facts upon the basis of the ordinary theory of the failure of steel at the elastic limit, or to make any further advance in the direction of answering the question, "What is the elastic limit of a steel?" The natural elastic limit appears to be a function which is not independent of the conditions under which it is determined. This is not so unreasonable as it might appear, since it is more than likely that the application of cyclical or fluctuating stresses to a piece of steel has some considerable effect upon its physical properties, with the result that, although the steel may have a certain natural elastic limit as defined above, yet when alternating stresses are applied to it, this natural elastic limit is changed. Some such change is almost bound to take place if the steel



is stressed by a plus fatigue stress which is greater than its apparent elastic limit, and particularly so if it is subjected to a plus fatigue stress greater than the yield-point, thus producing some degree of stretching.

The effect of the application of cyclical stress upon the other fundamental properties of a steel may be demonstrated, to some extent, by stressing a steel which has a low apparent elastic limit, in a Haigh machine. The results of such an experiment are shown in Table 14 and Fig. 58.

TABLE 14.

SHOWING THE EFFECT, UPON THE ELASTIC LIMIT OF QUENCHED STEEL, OF THE APPLICATION OF VARYING NUMBERS OF ALTERNATIONS OF STRESS.

Number of Cycles of Stress applied.	Elastic Limit, tons per sq. in.	
	Tension.	Compression.
0	14.2	14.9
1,000	18.45	17.1
101,000	19.2	17.8
639,000	20.6	19.9
1,153,000	> 21.8	> 21.8

A steel was used which had been hardened drastically by quenching in water, and it was stressed in tension and in compression for a definite number of reversals. After this treatment the steel was submitted to an ordinary static tensile test, and the apparent elastic limit determined. Another sample of steel similarly heat treated was subjected to a larger number of reversals, and the apparent elastic limit in tension subsequently determined. The resulting alteration of the apparent elastic limit, produced gradually by the increasing number of alternations of stress, is shown clearly in the table. As the steel in question had originally an exceedingly low elastic limit (apparent), and also had been drastically hardened,

it is not unreasonable to suppose that the effect of the alternating stresses upon the steel was the removal of some of the hardening strains present in the steel, just in the same way as the operation of tempering removes these strains, and just as the machining away of the surface of a piece of hardened steel releases the strains (see p. 112).

From the above discussion it should be clear that the fatigue range of a steel has little or no connection with the apparent elastic limit, as determined by an ordinary

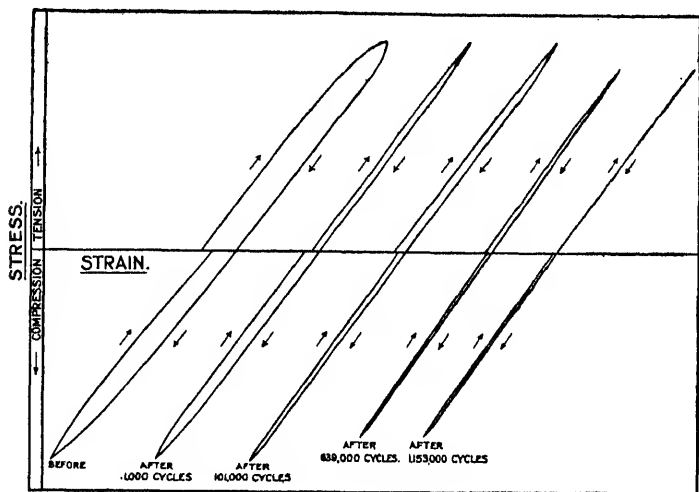

FIG. 58.—STRESS/STRAIN CURVES OF SAMPLES OF HARDENED STEEL AFTER SUBMITTING TO DIFFERENT NUMBERS OF CYCLES OF ALTERNATING STRESS

test. On the other hand, it should be fairly clear that the fatigue range is a property of steel which is of most vital importance, and that it is really the most important property of the steel to the designer (particularly of engines). It must be admitted, however, that the determination of the fatigue range of a piece of steel is by no means easy, and that it involves the expenditure of a considerable amount of time. It would be of the greatest possible value to the engineer if he

of a piece of steel by carrying out some simple test, or, better still, if he were able to obtain some idea of the value of the fatigue range of the steel from the determination of one of the other physical properties of steel which may be easier to obtain. The results obtained in a considerable series of experiments<sup>1</sup> suggest that it may be possible to do the latter, since, curiously enough, there appears, from these experiments, to be a fairly constant relationship between the maximum strength of a steel and its fatigue range. In Table 15 are set out a large number of results giving the apparent elastic limit, the yield-point, the maximum stress, and the fatigue range of a number of steels. In all these tests the fatigue range has been determined for equal plus and minus fatigue stresses. In addition to these figures, the ratio between the plus fatigue stress, and the ultimate strength, is given, and it will be seen that in the majority of cases this ratio is remarkably similar. The plus fatigue stress is approximately equal to the maximum stress multiplied by a factor which lies between 0·45 and 0·50, and, therefore, the fatigue range is very nearly equal to the maximum stress. In view of the very considerable variety of steels which have been examined, this result is of great importance, and although the ratio is only empirical, and has not been explained at present, its mere existence enables the engineer to assume the fatigue strength of a piece of steel with reasonable accuracy, without having to carry out a series of difficult and arduous operations. It is quite probable that this relationship between the fatigue strength of the steel and the maximum strength (hitherto hardly suspected) has been of tremendous use in the past to the engineer who has always taken some proportion of the maximum strength of a steel as his designing value, almost irrespective of the values for the elastic limit, yield-point, etc. This custom appears now to be largely justified.

<sup>1</sup> *Report of Materials Section, Air Ministry, H.M. Stationery Office, 1921.*

SHOWING THE FATIGUE RANGE OF DIFFERENT STEELS AND THE RATIO BETWEEN IT AND THE OTHER MECHANICAL PROPERTIES OF THE STEEL.

Description of Steel.	Elastic Limit, tons per sq. in.	Yield-point, tons per sq. in.	Maximum Stress, tons per sq. in.	Fatigue Range, tons per sq. in.	Ratio of Fatigue Range to :—	
					Elastic Limit.	Yield-point.
Plain carbon case-hardening .. ..	17.6	24.7	39.5	± 18.4	2.09	1.49
3 % nickel case-hardening .. ..	16.0	38.2	65.5	± 31.0	3.88	1.62
5 % nickel case-hardening .. ..	14.0	44.1	60.0	± 30.0	4.30	1.36
6 % nickel case-hardening .. ..	20.0	30.0	57.8	± 26.5	2.65	1.76
Air hardened, 100 ton .. ..	20.0	78.8	109.1	± 45.5	4.55	1.16
Air hardened, 100 ton, tempered 200° C.	36.2	77.5	101.2	± 51.5	2.85	1.33
Air hardened, 100 ton, tempered 400° C.	53.3	80.5	97.9	± 47.5	1.78	1.18
Air hardened, 100 ton, tempered 500° C.	51.7	71.3	82.4	± 41.5	1.61	1.16
Air hardened, 100 ton, tempered 600° C.	40.9	63.3	70.1	± 35.5	1.74	1.12
Hardened and tempered nickel chromium .. ..	55.0	59.5	65.7	± 33.0	1.20	1.11
Hardened and tempered nickel chromium .. ..	—	49.1	57.5	± 27.9	—	1.13
Hardened and tempered chromium vanadium .. ..	44.8	54.7	62.9	± 32.8	1.46	1.20
Plain carbon, normalised .. ..	23.1	24.9	37.9	± 17.0	1.47	1.37
Plain carbon, hardened and tempered .. ..	25.4	31.5	46.8	± 19.0	1.50	1.21
Cold worked plain carbon .. ..	18.2	36.8	40.8	± 19.1	2.10	1.04
Cold worked plain carbon, blued 550° C.	25.0	26.4	36.8	± 18.0	1.44	1.36

**The Valuable Mechanical Properties of Steel.**—After having examined, more or less critically, the different mechanical properties of steel, it seems desirable to go further, and to find out which of them are of the greatest value to the engineer. For statically loaded parts it seems to be quite clear that the proof stress is the most important property. The elastic limit is at present almost an unknown property, and the yield-point is too uncertain to be really reliable. The proof stress, on the other hand, means something which is quite definite, and at the same time is capable of easy and accurate determination. For parts loaded dynamically the fatigue range is undoubtedly of paramount importance. The apparent independence of almost all other properties makes this one even more important, and it cannot be replaced by any other property. Given whichever of the above two properties is the more appropriate, the engineer is really as fully equipped from the design standpoint as he possibly can be. In order, however, to ensure that the steel which he employs shall be in its best possible condition, the notched bar test is most valuable, and no other test or property can be imagined as suitable to replace it. These three properties—the proof load, the fatigue range, and the notched bar value—appear, therefore, to be the real criteria which the engineer should apply to his steel.

## CHAPTER V

### PLAIN CARBON STEELS

THE carbon steels which are useful to the engineer are of many different kinds, varying from the softest mild steel to the high carbon steel, used for fine tools. Speaking generally, the latter type is less important, and is dealt with in Chapter IX. The present chapter will, therefore, be confined to a consideration of the properties and characteristics found in the carbon steels used in engineering structures and prime movers. The amount of steel represented by this class alone is enormous, as will be appreciated readily from the fact that it embraces practically the whole of the steel used in railways, ship building, and general constructional work, such as bridges, railway stations, and other large buildings. With this tremendous field to survey, it is evident that any account of the steels which it contains must be confined to the fundamental properties thereof, and that the particular points regarding the steels, in their applications to special and definite forms of material or classes of duty, must be left to the more detailed consideration of them at other hands. The consideration of the cold worked steels, which are usually plain carbon steels, is put forward to Chapter VIII, whilst the plain carbon steels, as used for case hardening, are described in Chapter VII, so far as their mechanical and chemical properties are concerned.

The carbon steels are most frequently employed for parts which call for a steel having no greater strength than

about 36 tons to 40 tons per square inch. This is not the limit of useful strength for these steels, as will be shown later, but it represents a suitable and fair limit of strength to obtain from the carbon steels, without hardening and tempering. A limit of tensile strength of about 40 tons per square inch is usually associated with a carbon content of about 0.40 per cent., which is consequently the maximum amount usually found in the plain carbon structural steels. This fact limits the compositions that are of general interest to the engineer to a range of from 0.15 to 0.40 per cent. of carbon. In order to simplify discussion, it appears desirable first of all to indicate the mechanical properties of representative plain carbon steels lying within this range of composition. Illustrative figures are given in Table 16, and show the effect of different proportions of carbon upon the mechanical properties of the steels.

TABLE 16.

THE EFFECT OF CARBON CONTENTS UPON THE MECHANICAL PROPERTIES OF PLAIN CARBON STEELS.

Steel.	Carbon, %.	Yield-point, tons per sq. in.	Max. Stress, tons per sq. in.	Elongation, %.	Reduction of Area, %.
A	0.06	13	21	46	75
B	0.21	17	25	42	68
C	0.38	20	30	35	56
D	0.60	24	42	20	40
E	0.89	25	52	13	15

The figures given in Table 16 indicate solely the effect of varying carbon contents upon the mechanical properties of steel, since the steels whose properties are quoted are remarkably pure. This can be seen from the compositions quoted in Table 17, the steels examined being the same as those quoted in Table 16.

TABLE 17.

COMPLETE CHEMICAL COMPOSITION OF STEELS QUOTED IN  
TABLE 16.

Steel.	Carbon, %.	Silicon, %.	Manganese, %.	Sulphur, %.	Phosphorus, %.
A	0.06	0.03	0.04	0.031	0.024
B	0.21	0.05	0.05	0.032	0.024
C	0.38	0.03	0.08	0.028	0.023
D	0.60	0.07	0.10	0.027	0.022
E	0.89	0.03	0.09	0.028	0.024

The test results given in Table 16 have been obtained from samples which have not been hardened or tempered. They therefore represent the steels in the condition in which they are more frequently employed, i.e., the normalised condition.

Steels of such composition as those given in Table 17 are but rarely met with. In commercial work they are hardly ever met with, and the differences of chemical composition between such steels and those steels usually found in commerce exert a distinct effect upon the mechanical properties of the steel. This influence may well be considered first of all.

The composition of carbon steels is affected considerably by the process by which the steels are manufactured. The steels quoted in Tables 16 and 17 were made in the crucible furnace. Steel made in this way is rarely met with in general engineering practice, except in tools. The carbon steel of commerce is nowadays almost invariably made in the open-hearth or Siemens-Martin furnace—either acid or basic. A small proportion is made by the Bessemer process, though the output of such steel is decreasing rapidly. In steel made in these ways, several things operate to make the composition rather different from that of steel made in the crucible furnace. A good deal more manganese is found in the finished product,



because more is added to make the steel quite sound and free from oxide of iron. The base materials—pig iron and scrap—are rarely so pure as those used for the manufacture of crucible steel, so that sulphur and phosphorus are usually present in higher proportions in the open-hearth and Bessemer steels than in the crucible steels. The result is, that steels made in these ways usually contain more manganese, sulphur, and phosphorus than do the crucible steels. These differences in composition are, in some ways, incidental to the method of manufacture, but it must not be assumed, in consequence, that all crucible steels have a low manganese or sulphur or phosphorus. Also it is advisable for the engineer to consider the influence of manganese (which is the most important difference in the compositions of the steels) on its merits, and not to attach it mentally to, or to connect it in any way definitely with, a particular method of the manufacture of steel. Analyses to illustrate the above points are given in Table 18, the steels quoted there being an indiscriminate mixture of open-hearth, Bessemer, and electric steels.

TABLE 18.

SHOWING TYPICAL CHEMICAL COMPOSITIONS OF VARIOUS COMMERCIAL PLAIN CARBON STEELS.

Steel.	Carbon, %.	Silicon, %.	Manganesec, %.	Sulphur, %.	Phosphorus, %.
A	0.10	0.04	0.35	0.032	0.005
B	0.14	0.01	0.56	0.048	0.088
C	0.74	0.21	0.71	0.062	0.073
D	0.21	0.11	0.59	0.077	0.089
E	0.22	0.04	0.62	0.028	0.008
F	0.44	0.26	0.32	0.028	0.027
G	1.05	0.14	0.42	0.043	0.038
H	1.22	0.	.39	.49	.026

The figures in Table 18 illustrate very clearly that the ordinary engineering steels of commerce contain an appreciable quantity of manganese. In the average plain carbon steel, the proportion of this element runs from about 0.5 to 1.0 per cent. The proportion of silicon varies somewhat, but the quantity present is never of any vital importance to the steels under discussion, as this element is rarely found in amounts greater than about 0.30 per cent. The sulphur and phosphorus contents of the open-hearth and Bessemer steels are usually distinctly greater than those of the crucible steels. So far as the mechanical properties (as revealed by tests) are concerned, these elements in the ordinary proportions found in commerce are of no great importance. (The general question of the limits of sulphur and phosphorus is discussed at the end of this chapter.) It is evident therefore that, after the carbon, the most important element to take into account is the manganese. The effect of this element, upon the mechanical properties of the plain carbon steels, can be seen most easily by examining the properties of steels of different carbon content with a high and a low proportion of manganese. The requisite test results are given in Table 19.

TABLE 19.

THE EFFECT OF HIGH AND LOW MANGANESE CONTENTS UPON THE MECHANICAL PROPERTIES OF PLAIN CARBON STEELS IN THE NORMALISED CONDITION.

Carbon, %.	Manganese, %.	Yield-point, tons per sq. in.	Max. Stress, tons per sq. in.	Elongation, %.
0.21	0.05	17	25	42
0.25	0.85	25	37	30
0.38	0.08	20	30	35
0.36	0.58	26	35	28
0.37	0.82	27	43	25
0.49	0.09	22	36	27
0.47	0.70	29	42	26
0.50	0.80	30	50	20

The test figures given in Table 19 show that the general effect of manganese is to strengthen the steel, or, in other words, that much the same tensile strength may be obtained in a steel by replacing some of its carbon with a rather greater proportion of manganese. A steel with a lower carbon and high manganese may be quite as strong as a steel containing a higher carbon and a lower content of manganese. The strengthening effect of the manganese is made still more apparent when the mechanical properties of the carbon steel after hardening and tempering are considered. To appreciate this effect it is necessary to examine the results of tests made upon steels of approximately the same carbon content, some of them having a high and some a low proportion of manganese. The test results given by such a series of steels, after hardening and tempering, are shown in Table 20.

TABLE 20.

EFFECT OF HIGH AND LOW MANGANESE CONTENTS UPON THE MECHANICAL PROPERTIES OF HEAT TREATED PLAIN CARBON STEELS.

(Each steel was treated in bars  $1\frac{1}{8}$  inch diameter.)

Carbon, %.	Manga- nese, %.	Heat Treatment.	Yield- point, tons per sq. in.	Max. Stress, tons per sq. in.	Elonga- tion, %.
0.31	1.54	{ Water quenched and tempered 650° C. }	37.6	48.5	24.0
0.32	0.63		29.0	41.8	25.0
0.31	1.54	{ Water quenched and tempered 700° C. }	38.8	45.3	24.0
0.32	0.63		26.4	39.4	32.0
0.22	1.20	{ Water quenched and tempered 650° C. }	34.0	41.4	30.5
0.27	0.52		28.2	39.2	30.0
0.22	1.20	{ Water quenched and tempered 700° C. }	31.9	39.2	32.0
0.27	0.52		25.5	36.3	33.0

The figures in Table 20 are not extremely striking, but they do show that the manganese strengthens the

plain carbon steels quite distinctly. Still more striking evidence can be obtained by treating steels containing different proportions of manganese, in bars of different sizes. If such tests are made, it is found that the mass effect in hardening (see p. 70) is very much less pronounced in steels high in manganese, than in those low in that element. Suitable tests for the illustration of this effect of the manganese are given in Table 21.

TABLE 21.

SHOWING THE EFFECT OF MASS UPON CARBON STEELS CONTAINING DIFFERENT PROPORTIONS OF MANGANESE.

The compositions of the two steels were :

	A	B
Carbon ..	0.32 per cent.	0.32 per cent.
Manganese ..	0.73 „	2.50 per cent.

*(The steels were treated in bars  $3\frac{1}{4}$  inches diameter.)*

Steel.	Heat Treatment.	Position Tested.	Brinell Hardness Number.
A	Oil hardened 850° C.	Skin	207
A	Oil hardened 850° C.	Centre	179
B	Oil hardened 850° C.	Skin	321
B	Oil hardened 850° C.	Centre	302
A	Water hardened 850° C.	Skin	255
A	Water hardened 850° C.	Centre	196
B	Water hardened 850° C.	Skin	512
B	Water hardened 850° C.	Centre	444

The above discussion should go to show that the steels usually termed plain carbon steels are really not plain carbon steels at all, but carbon-manganese steels, and that the so-called plain carbon steels are really a type of alloy steel, the alloying element being manganese, which is present in only a comparatively restricted proportion, but nevertheless sufficient to make a distinct impression upon the properties of the steel. This being so, it is always

of importance to consider both carbon and manganese when judging the chemical composition of the plain carbon steels. The establishment of this fact should clear the way for a consideration of the effects of hardening and tempering upon the mechanical properties of the plain carbon steels. These effects can be seen most distinctly by considering the test results quoted in Tables 22 to 24.

TABLE 22.

THE MECHANICAL PROPERTIES OF STEEL CONTAINING  
 CARBON .. .. . 0.14 per cent.  
 SILICON .. .. . 0.07 „  
 MANGANESE .. .. . 0.44 „

AFTER HARDENING IN WATER FROM 900° C. AND TEMPERING AT DIFFERENT TEMPERATURES.

(Diameter of specimens at time of heat treatment—1½ inches.)

Tempering Temperature, ° C.	Yield-point, tons per sq. in.	Max. Stress, tons per sq. in.	Elongation, %.	Reduction of Area, %.	Izod Impact, ft.-lb.
—	25	34	33	70	104
300	25	33	37	71	109
400	25	33	35	70	106
500	23	33	36	70	107
600	24	32	37	73	104

A typical series of results is plotted in the curves given in Fig 59. The test results given in Tables 22 to 24 show that very little mechanical advantage results from the hardening and tempering of the lower carbon steels. It is only when the proportion of carbon rises above 0.25 per cent. that the process is in any way remunerative from the point of view of the strength of the steel. Even with this proportion of carbon the advantage is by no means great. There is, however, a distinct difference in the toughness (as shown by the impact value) of the steels

TABLE 23.

THE MECHANICAL PROPERTIES OF STEEL CONTAINING

CARBON .. .. . 0.31 per cent.

SILICON .. .. . 0.11 ,,

MANGANESE .. .. . 0.58 ,,

HARDENED FROM 850° C. IN WATER AND TEMPERED AT DIFFERENT TEMPERATURES.

*(Diameter of specimen at time of heat treatment—1½ inches.)*

Tempering Temperature ° C.	Yield-point, tons per sq. in.	Max. Stress, tons per sq. in.	Elongation, %.	Reduction of Area, %.	Izod Impact, ft.-lb.
—	35.2	51.2	15.9	42.1	23
100	34.6	49.7	17.7	43.7	31
200	34.6	49.5	19.3	44.2	36
300	33.7	48.2	21.0	45.8	40
400	35.2	50.3	17.1	43.6	34
500	32.6	46.6	23.3	55.1	69
600	26.4	42.5	26.1	59.4	78
700	25.9	37.6	28.7	62.1	89

TABLE 24.

THE MECHANICAL PROPERTIES OF STEEL CONTAINING

CARBON .. .. . 0.45 per cent.

SILICON .. .. . 0.25 ,,

MANGANESE .. .. . 0.75 ,,

AFTER HARDENING IN WATER FROM 870° C. AND TEMPERING AT DIFFERENT TEMPERATURES.

*(Diameter of specimen at time of heat treatment—1½ inches.)*

Tempering Temperature ° C.	Yield-point, tons per sq. in.	Max. Stress, tons per sq. in.	Elongation, %.	Reduction of Area, %.	Izod Impact, ft.-lb.
—	45	65	11	28	13
300	44	65	11	23	14
400	46	60	15	46	17
500	39	55	22	56	32
600	33	49	26	64	54
700	30	42	27	66	54

which have, and those which have not, been heat treated. This difference is most marked in the steels containing the higher proportions of carbon, and in such steels the advantage of heat treatment is manifest (see the results given in Table 24). The subject of the advantage of heat treatment to the mechanical properties of steels is

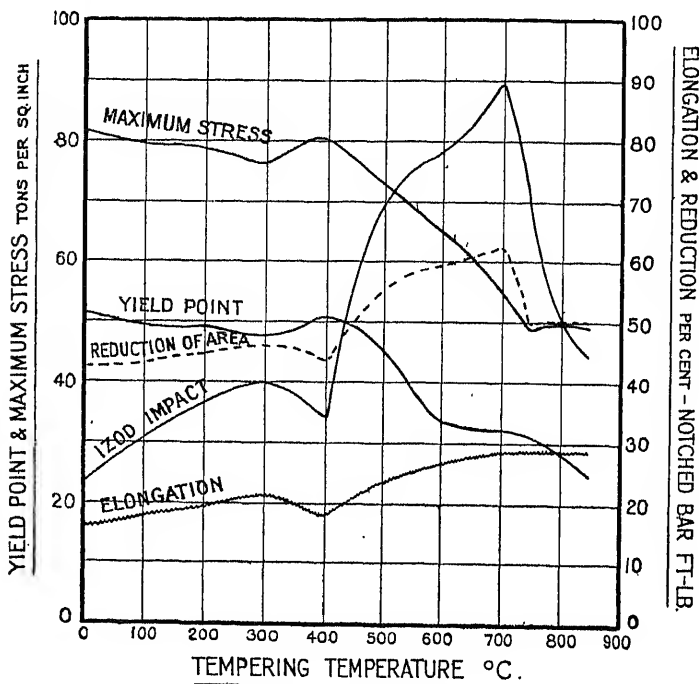

FIG. 59.—THE EFFECT OF TEMPERING AT DIFFERENT TEMPERATURES UPON THE MECHANICAL PROPERTIES OF PLAIN CARBON STEEL.

discussed generally on p. 81, and the general conclusions reached in that discussion apply fully to the particular class of steel dealt with in this chapter.

The test figures given in the previous table indicate the possibilities of improving the mechanical properties of the plain carbon steels. They would not be complete, how-

hardening and tempering upon the mechanical properties. The mass effect is indicated by the test results given in Tables 25 and 26. The figures require no comment other than that they indicate the comparative uselessness of attempting to produce even moderately high strengths in parts of large size which are made in plain carbon steel.

As stated above, the majority of parts made in plain carbon steels are used in the "non-heat treated" condition, that is to say, they are not hardened and tempered. This is doubtless inevitable for various reasons, such as the difficulty of handling large masses, but there is no reason at all why such steels should not be normalised. The effect of normalising upon the properties of steel is dealt with in connection with the description of that process as given on p. 63, and the reasons advanced there for carrying out the process apply mainly to plain carbon steels, being, in fact, concerned almost exclusively with such steels, since the alloy steels are almost invariably used in the hardened and tempered condition. These considerations should be taken into careful account when considering the plain carbon steels, and a good rule to observe is that all the plain carbon steels, which are not to be hardened and tempered, should be normalised.

In connection with the plain carbon steels it is necessary to make some reference to the effect which the method of manufacture has upon the properties of the steels. It is customary to consider that acid and basic steels—which may be taken as the usual rough division of the steels—have distinctly different properties, the general opinion being that the basic steels are inferior to the acid steels. This belief is difficult to understand in the light of modern knowledge. It is doubtless a survival of an ancient prejudice which has been sedulously fostered by the makers of acid steel. When the case is examined quite impartially, the real inferiority of basic steel is difficult to trace. It may be admitted that the basic steels of a particular carbon content are usually a little



TABLE 25.

THE EFFECT OF MASS DURING HARDENING UPON THE MECHANICAL PROPERTIES OF STEEL CONTAINING

CARBON	..	..	..	..	0.20 per cent.
SILICON	..	..	..	..	0.13 ,,
MANGANESE	..	..	..	..	0.95 ,,

ALL THE BARS WERE QUENCHED FROM 760° C. AFTER REFINING AT 900° C.

*(Tests made upon the core of the specimens.)*

Size of Bar, inches diameter, at time of Heat Treatment.	Yield-point, tons per sq. in.	Max. Stress, tons per sq. in.	Elongation, %.	Izod Impact, ft.-lb.
2½	23.6	39.1	35.0	86
1½	24.8	43.5	35.0	100
¾	27.3	55.4	25.0	75

TABLE 26.

THE EFFECT OF MASS UPON THE MECHANICAL PROPERTIES AFTER HEAT TREATMENT OF STEEL CONTAINING

CARBON	..	..	..	..	0.45 per cent.
SILICON	..	..	..	..	0.25 ,,
MANGANESE	..	..	..	..	0.75 ,,

ALL THE BARS WERE QUENCHED FROM 870° C. IN WATER.

*(Tests made upon the core of the specimens.)*

Size of Bar, inches diameter, when heat treated.	Tempering Temperature °C.	Yield-point, tons per sq. in.	Max. Stress, tons per sq. in.	Elongation, %.	Izod Impact, ft.-lb.
3	—	29	50	21	19
2½	—	37	53	19	16
11/16	—	69	78	15	3
3	500	34	49	24	33
2½	500	34	51	24	35
11/16	500	50	61	16	53
3	600	28	47	25	33
2½	600	31	49	25	43
11/16	600	45	56	23	79

**The Valuable Mechanical Properties of Steel.**—After having examined, more or less critically, the different mechanical properties of steel, it seems desirable to go further, and to find out which of them are of the greatest value to the engineer. For statically loaded parts it seems to be quite clear that the proof stress is the most important property. The elastic limit is at present almost an unknown property, and the yield-point is too uncertain to be really reliable. The proof stress, on the other hand, means something which is quite definite, and at the same time is capable of easy and accurate determination. For parts loaded dynamically the fatigue range is undoubtedly of paramount importance. The apparent independence of almost all other properties makes this one even more important, and it cannot be replaced by any other property. Given whichever of the above two properties is the more appropriate, the engineer is really as fully equipped from the design standpoint as he possibly can be. In order, however, to ensure that the steel which he employs shall be in its best possible condition, the notched bar test is most valuable, and no other test or property can be imagined as suitable to replace it. These three properties—the proof load, the fatigue range, and the notched bar value—appear, therefore, to be the real criteria which the engineer should apply to his steel.

lower in tensile strength than the acid steels with the same proportion of carbon. This fact, however, is quite well known, and the difference in strength is of the order shown by the figures in Tables 27 and 28.

TABLE 27.

THE MECHANICAL PROPERTIES OF TYPICAL ACID OPEN-HEARTH STEELS (NORMALISED).

Carbon, %.	Yield-point, tons per sq. in.	Max. Stress, tons per sq. in.	Elongation, %.	Reduction of Area, %.
0.13	13.6	24.5	29.2	62.3
0.18	13.2	30.3	27.2	57.4
0.37	16.5	37.0	21.8	45.5
0.44	21.9	43.6	19.8	41.3
0.57	27.2	50.4	11.6	26.1

TABLE 28.

THE MECHANICAL PROPERTIES OF TYPICAL BASIC OPEN-HEARTH STEELS (NORMALISED).

Carbon, %.	Yield-point, tons per sq. in.	Max. Stress, tons per sq. in.	Elongation, %.	Reduction of Area, %.
0.12	12.3	24.5	23.0	63.0
0.20	14.9	28.5	23.6	61.0
0.35	21.2	37.8	20.7	40.1
0.45	22.5	42.5	14.3	38.7
0.60	26.6	51.5	8.3	34.7

This difference in tensile strength, by itself, does not constitute a real inferiority, and the reasons for the belief in the inferiority must be looked for elsewhere, if they exist. From the point of view of composition, the advantage appears to be with the basic steel. Sulphur and phosphorus are usually regarded as a criterion of

basic steels have no disadvantage. The composition of some acid and basic steels are given in Tables 29 and 30.

TABLE 29.

SOME TYPICAL CHEMICAL COMPOSITIONS OF ACID OPEN-HEARTH STEELS.

Carbon, %.	Silicon, %.	Manganese, %.	Sulphur, %.	Phosphorus, %.
0.13	0.026	0.40	0.031	0.055
0.18	0.037	0.71	0.024	0.052
0.37	0.040	0.57	0.021	0.052
0.44	0.042	0.71	0.059	0.041
0.57	0.047	0.71	0.047	0.048

TABLE 30.

SOME TYPICAL CHEMICAL COMPOSITIONS OF BASIC OPEN-HEARTH STEELS.

Carbon, %.	Silicon, %.	Manganese, %.	Sulphur, %.	Phosphorus, %.
0.12	0.035	0.40	0.027	0.057
0.20	0.032	0.51	0.043	0.052
0.35	0.012	0.85	0.049	0.071
0.45	0.031	0.72	0.051	0.060
0.60	0.034	0.71	0.061	0.070

Doubtless a wider understanding of the facts indicated by the figures in Tables 27 to 30 will lead to a still greater appreciation of the basic steels. Another point, which should not be lost sight of, is the fact that practically all the steels made in the electric furnace are really basic steels. They are made in furnaces lined with the same materials as are employed for the linings of basic open-hearth and Bessemer furnaces, and yet no objection is ever taken to the electric steels on this account.

examine the mechanical properties of the steel in a critical manner, to see how far they provide the necessary qualities for this service. The simple tensile properties have been quoted in full above, but these in themselves are not sufficient for the purposes of the inquiring engineer. Two other properties require to be investigated, (1) the fatigue range, and (2) the toughness, or the impact value, of the steels. The fatigue range of the steels has frequently been determined by various workers from Wöhler onwards, and particular reference should be made to the work of Strohmeier,<sup>1</sup> Bairstow,<sup>2</sup> Eden Rose and Cunningham,<sup>3</sup> Haigh,<sup>4</sup> and the Technical Department of the Air Ministry.<sup>5</sup> In many instances it is not possible to extract the fullest amount of information from the reports of the investigations upon fatigue range, because the requisite details of chemical composition and heat treatment are not available. In some reports, also, the other mechanical properties of the steel (e.g., the tensile strength) are not quoted. These necessary adjuncts to the tests are not missing, however, from the report of the Technical Department of the Air Ministry, and, therefore, the results given in that report may be quoted in a fuller and more useful manner than any others. It must be said at once, that there has been a considerable lack of agreement among the results obtained by the different workers, though this may, perhaps, be traced in some measure to the incomplete nature of the information provided by the different investigators. It is not possible to compare the results obtained by one worker upon material described simply as "mild steel," with those of an entirely separate worker upon material similarly described, but which may prove to be very different in composition and treatment when the complete facts regarding both steels are available.

<sup>1</sup> *Manchester Steam Users' Association Memorandum*, by Chief Engineer, 1913.

<sup>2</sup> *Phil. Trans. Roy. Soc. A.* vol. 210, p. 35.

<sup>3</sup> *Proc. Inst. Mech. Eng.*, October 1911.

<sup>4</sup> *Journ. Inst. Metals*, 1917, i.

<sup>5</sup> H.M. Stationery Office, 1921.

When all the information is tabled, the results of all the tests may possibly lead to a similar conclusion. This conclusion, particularly in so far as the more recent work is concerned, is that the fatigue range (see p. 130) is approximately 92 to 98 per cent. of the maximum stress. No connection has been traced between the fatigue range and the elastic limit or the yield-point, but the relationship between the fatigue range and the maximum stress is fairly constant and quite uniform. The same relationship is found to hold for the alloy steels (see p. 137). It need hardly be said that this ratio is quite empirical, and has received up to the present no explanation, either theoretical or otherwise. The nature of the relationship can be seen from the results given in Table 31.

TABLE 31.

SHOWING THE MECHANICAL PROPERTIES IN TENSION AND FATIGUE OF A STEEL CONTAINING

CARBON	..	..	..	..	0.36 per cent.
SILICON	..	..	..	..	0.25 "
MANGANESE	..	..	..	..	0.66 "
SULPHUR	..	..	..	..	0.041 "
PHOSPHORUS	..	..	..	..	0.020 "

AFTER NORMALISING (850° C.), AND AFTER HARDENING (850° C. IN OIL) AND TEMPERING (600° C.).

(Diameter of specimens at time of treatment— $1\frac{1}{8}$  inches.)

Heat Treatment.	Elastic Limit, tons per sq. in.	Yield-point, tons per sq. in.	Max. Stress, tons per sq. in.	Elongation, %.	Reduction of Area, %.	Fatigue Range, tons per sq. in.	
						Wöhler.	Haigh.
Normalised .. ..	23.1	24.9	37.9	31.1	57.9	±17	±15
Hardened and tempered	28.4	31.5	46.8	28.3	62.3	±19	±18

The second item of importance in the mechanical properties is the impact or notched bar value of the steels.

It is not possible to discuss this property without making some reference to the corresponding values which are obtained from the alloy steels, particularly those of approximately the same tensile strength as the carbon steels under discussion. The last condition limits the comparison of the two classes of steel to the carbon steels of over 35 tons maximum strength, since this represents, approximately, the lowest tensile strength which can be expected from the structural alloy steels. Strictly speaking, the comparison ought also to be made only between the hardened and tempered steels in each class, since the alloy steels are almost invariably used in this condition.

When the notched bar test figures are examined, it is found that one of the most prominent characteristics of the plain carbon steels is the comparative uncertainty of the results obtained. For no apparent reason, results of the order of 80 foot-lb. are obtained upon the same class of steel as gives only 15 foot-lb. in another test. This means that, in general, the value which can be specified for the carbon steel is lower than that for the alloy steel. It is usually found that the carbon and the alloy steels give different notched bar values from samples of the same tensile strength, the values for the carbon steel being lower than those for the alloy steel. Sometimes this may be due to the fact that the alloy steel has necessarily been tempered at a very high temperature in order to give the low tensile strength required for comparison, and has, therefore, been put into the condition most suitable for the production of a high impact value, whereas the carbon steel, which does not harden initially to such a high tensile strength, has been tempered at a lower temperature in order to produce the same tensile strength in the finished specimen. Whatever may be the reasons, the fact remains that the carbon steels are rarely so tough (the toughness being measured by the notched bar test) as the alloy steels of corresponding strength.

It has been found that the notched bar value of the plain carbon steels can usually be improved considerably

by the addition to the steel of a small proportion of nickel or of chromium, i.e., between 0.5 and 1.0 per cent. of either element. This proportion is quite enough to produce distinctly superior notched bar values, and, what is more, to enable them to be obtained with greater regularity. Strictly speaking, the addition of the nickel and the chromium lifts the steel out of the category of plain carbon steels, but the proportion of nickel is so much lower than is ever put into the true alloy steels, that it can hardly be considered sufficient to warrant an alteration in the customary denomination of the carbon steels.

In the chapter on alloy steels, the "soundness" of the steels, or the freedom with which they can be manufactured without surface cracks and flaws, is discussed (see p. 205). It is pointed out there, that one of the factors which profoundly influence the soundness of the alloy steels is the ease with which they harden in the air. No such influence is at work during the casting and the forging of the plain carbon steels, with the result that the production of these steels in a comparatively sound state is a distinctly easier process. Theoretically, it should be comparatively easy to manufacture plain carbon steels without surface flaws and defects, and if the same amount of attention were paid to these steels as is given to the alloy steels during their production, this desirable result would be obtained. This matter is, however, of only indirect interest to the engineer, though of very direct importance to the metallurgist, since the former is not entitled to any anxiety on the score of the soundness of the surface of the carbon steels he is using.

Mention was made earlier in this chapter of the variations which occur in the chemical composition of carbon steels. It was stated there that the two elements which are not wanted, but which are always present, in steel, are sulphur and phosphorus. The influence of these two elements upon the quality of the steel is very well worth close investigation, as many misconceptions appear to exist.



are impurities, and are, therefore, undesirable. It is also true, however, that, taking the facts of the situation as they are, and as they are likely to remain, steel cannot be made entirely free from sulphur and phosphorus. A certain proportion of these elements will always be found in steel, whilst it is made as at present. This being so, the important thing to decide is the maximum proportion of sulphur and phosphorus which shall be regarded as harmless. This is a complicated matter to decide, and requires very careful consideration. The complications arise from several sides. In the first place, the way in which a steel is to be used has a considerable bearing upon the subject. The content of impurity, which would be quite harmless in a hot rolled sheet, appears to be accompanied by complete failure if that sheet is subsequently cold rolled to a thin strip which is to be used for deep pressings. In the second place, the two elements, although they are frequently classed together and treated almost as one and the same thing, are by no means similar in their effects or their influence. A third point, and the one which is most often overlooked, is the fact that the condition in which the elements are present in the steel has a big effect upon the degree to which they can be considered harmful. This is a point of very great importance indeed. A fourth point, and this is possibly the most vital of all, is the distribution of the sulphur and the phosphorus. If a steel is not made in the best possible manner, a considerable variation in the content of sulphur and phosphorus may easily be found in the different parts of the ingot. This segregation, as it is termed, is a very important matter. The causes which lead to its production are fully described in the section of this book dealing with ingots and macrostructure (see pp. 24 and 34). The segregation may lead to a very seriously different proportion of sulphur in one part of an ingot as compared with that in another part. A typical bad case is shown by the sulphur print in Fig. 22. It may be taken also

as generally true that, when there is a segregation of sulphur, there will be a segregation of phosphorus. This segregation means that, even if the average sulphur content of the steel is only 0.04 per cent., some parts of the billet may contain perhaps 0.12 per cent., and another part only 0.03 per cent., representing the good and bad extremes.

Various specifications have been drawn up in the past to limit the quantity of sulphur and phosphorus which is permissible in the steels used for different purposes. For instance, the specification for railway axles calls for sulphur and phosphorus to be not more than 0.035 per cent. In rails the limit allowed is 0.06 per cent. of each element. It seems reasonable to inquire a little as to the reason for the choice of these figures, particularly the low ones for axles. It is generally found that the answer, which is obtained to an inquiry as to the grounds upon which the choice was made, is to the effect that, at some time or other, material containing higher percentages of sulphur and phosphorus than those now specified, was found to be unsatisfactory, or that it failed in practice. It is the general practice nowadays to make an analysis of a part which has failed, and if the sulphur or the phosphorus content happens to be slightly in excess of that usually recorded, to lay the whole of the blame for the failure upon this excess (which may be quite small). This practice is definitely unfortunate. In the first place, it is misleading, because, by the too rapid assumption that the sulphur or phosphorus is the cause of the failure, other paths of investigation, which might lead to the discovery of important facts, are automatically closed, or, at any rate, are left unexplored. In the second place, it is misleading, because even though one or two parts which fail are found to contain this excess of sulphur or phosphorus, it is more than likely that there are large numbers of other parts with an equal proportion of sulphur or phosphorus which have done quite satisfactory service, whose existence is overlooked because they have not broken.

and whose career or virtue is ignored altogether in the assessment of the influence of these elements.

To the author, the question of the limits of sulphur and phosphorus, which can be allowed with safety, appears in the following light. It is an undoubted fact that sulphur and phosphorus are impurities, and are never added purposely to steel, except in the case of the "free-cutting" steels as developed largely in the United States for the sake of easy and rapid machining in automatic machine tools. The quantity which appears in the final steel is, therefore, largely a measure of the excellence or otherwise of the raw materials used, and of the degree of skill employed by the steelmaker in the manufacture of the steel. If steel is made from comparatively inferior raw materials, and, at the same time, is made with comparative carelessness, the sulphur and phosphorus may be relatively high. The bad properties which the steel may possess are not necessarily due to the excessive sulphur and phosphorus. The presence of this excess merely acts as a label for the steel, and the bad properties may, and frequently do, arise from other inferiorities of the steel, and not from the actual sulphur and phosphorus contents. A very similar instance is that of the proportion of silicon in steel rails. When such steel (and, in fact, practically all structural steel) was made in the Bessemer furnace, the presence of high silicon was a fairly certain indication that the blow had been too hot, i.e., that the steel was more or less wild, and would, therefore, be unsound. To guard against such steel being accepted, it was customary to specify that the silicon content of the steel should be quite low, not because the silicon in the steel did harm, but because the steel containing the higher quantities of silicon had, almost invariably, other bad qualities. The silicon became, therefore, a signpost or label of the quality of the steel, but had no more real influence upon the quality of the steel than the signpost has upon the nature of the surface of the road which it indicates. When the practice of making such steel in

the Bessemer furnace was discontinued, the silicon content lost its significance, and it became gradually clear that to insist upon the previous limits fixed for this element would be futile and misleading. The author feels that, in a large measure, the limitation of the sulphur and phosphorus stands upon much the same footing. In many specifications, the limits of impurities inserted are a survival from the days when the art and practice of steelmaking had not attained its present standard, and that, whereas a content of perhaps 0.0x was suitable in the days gone by, a content of probably 0.0 (*x plus 2*) is much fitter to represent the present-day practice. This conclusion assumes, of course, that the highly objectionable segregation described above has not occurred. Undue segregation, however, is a hall mark of inferior steelmaking, and if the sulphur and phosphorus contents were found to vary considerably in the steel, this fact alone would constitute an excellent signpost, as described above, that the steel had not been properly manufactured, and would form an exceedingly good ground for the rejection of the steel by the wise engineer.

To the engineer, the importance of all this discussion is very great, and the outcome of it appears to be that the percentage of sulphur and phosphorus which he shall allow, does not depend upon quite the simple factors usually imagined, but upon others which are rather more difficult to define, and distinctly more difficult to incorporate in a specification. These factors appear to be, first, the method employed for the manufacture of the steel, and secondly, the skill and proved capability of the maker of the steel. In other words, the engineer should be guided in fixing the limits of sulphur and phosphorus which he will allow in his steel, by his knowledge of the previous history of its manufacturer. If the maker is known by experience to be one who chooses his materials wisely and makes his steel carefully, a higher sulphur and phosphorus limit might be well and safely allowed, than could be permitted to a steelmaker who has not displayed

the above requisite qualities to the same extent. A still sounder basis would be to allow a distinctly higher sulphur and phosphorus content to the steelmaker who produced ingots and billets free from any undue segregation, than to the one whose products indicated a large variation of these two constituents in different parts of the same billet. In the author's opinion, the insistent examination of sulphur prints, taken from sections of ingots and billets, would provide a much better and safer criterion for the acceptance of steel, than would the examination of the sulphur contents as revealed by chemical analysis, which, after all, gives simply the "ultimate" composition of the steel, and provides no information at all regarding the "proximate" composition, or the distribution of the harmful elements.

## CHAPTER VI

### ALLOY STEELS

IN the previous chapter on carbon steels, it has been shown that the tensile strength, which can be obtained from carbon steels as are suitable for structural or machine purposes, is not particularly high. Even after the heat treatment, those carbon steels which can be suitably worked and manufactured reasonably, can only be expected to give an ultimate strength of about 55 tons per square inch. When a carbon steel is treated to give this strength, the impact value of the steel is usually quite low. The majority of test results go to show that it is practically impossible to obtain, in a carbon steel, both a moderate high tensile strength and a reasonably high notch strength value. It was also stated that, even with ordinary strengths, good notched bar results can only be obtained with comparative difficulty and with no real regularity. It was pointed out, both in the previous chapter and in the chapter on Heat Treatment, that the carbon steels are particularly prone to suffer from the effect of martensite hardening, and that it is very difficult to treat them in such a way that a good and uniform strength is obtained throughout parts of large mass. The introduction and development of alloy steels has come about largely as a consequence of the desire to overcome these various difficulties. By the use of alloy steels the engineer has at his command, materials which will give him practically any tensile strength which he requires, within a range of from 40 tons to 110 tons per square inch, and,

same time, will give him a good and satisfactory impact value at any of the strengths, the average values ranging from 60 ft.-lb. in steel of 40 tons strength to 12 ft.-lb. in steel of 100 tons per square inch. In addition to the very considerable range of mechanical properties which are made available for the engineer, it should be remembered that the alloy steels are capable of being heat treated with comparative ease. Also, the mechanical results which are required can be produced with considerable regularity. By a suitable selection of steel, practically all the troubles connected with the effect of mass can be avoided or overcome. How this is brought about in the alloy steels is duly explained in the chapter on Heat Treatment, but it may be well to reiterate the statement that the alloy steels harden very intensively (i.e., produce at high temperatures a solid solution which is very stable, and has but a small tendency to decompose during cooling), and, therefore, become hard from the surface to the centre of even the largest mass, if a steel of suitable composition be employed.

Since the structural alloy steels are more expensive than the structural carbon steels, and also since they are more difficult to forge or to drop stamp, it is obvious that they should be used only in those parts which call for the use of steel which possesses such mechanical properties as cannot be supplied by plain carbon steel. This means that, when the alloy steels are used, full advantage should be taken of their good properties, and, therefore, that the alloy steels should be used in either the hardened, or the hardened and tempered, condition. The fully hardened condition is rarely the best to use, and it may be taken as generally true (this matter is dealt with fully on p. 203) that alloy steel should always be used in the hardened and tempered condition. Some of the alloy steels can be hardened perfectly by merely cooling in air from the hardening temperature. Others require to be cooled in oil. On the other hand, some of the alloy steels only develop their best properties if they are cooled in water in the

manner employed for many of the carbon steels. Whatever method of cooling is employed, the hardened steel can be tempered in a perfectly normal manner.

The number of alloy steels in use at the present time is legion, and it is impossible, besides being unnecessary, to deal with each of them singly. It is surely better to take a different basis than that of composition, on which to compare and describe these steels, and to classify the steels according to their mechanical properties. To the engineer the mechanical properties of a steel are of paramount importance. What he requires in a steel is that it shall be sufficiently strong to stand up to the work which it is expected to perform, and, at the same time, shall have the other desirable properties of ductility and high notched bar value, not that it shall contain a specific proportion of nickel or of vanadium. The specific proportions of such elements present in the steel are means to an end, and it is of the utmost importance that this fact should be realised, since there is a very unfortunate tendency to consider that the composition is not the means, but the end. Many engineers have been misled by the repeated and mystic use of the words "nickel chromium," into the employment of some steel which was entirely unsuitable, possibly much more expensive, and unnecessarily good for the work. It is proposed, therefore, to divide up the range of tensile strength, which is usually obtained from the alloy steels, into sections. Each section covers a certain small range of tensile strength, the extent of the range being generally that which would be allowed in a specification for steel which was chosen for any particular part. For each section, the alloy steels which will give, with the greatest ease and regularity, the particular properties required, will be described, together with the heat treatment necessary for the production of these properties, and an indication of any peculiarities which these particular steels possess. It is not claimed that the steels selected for description are the only ones which will give the required properties, but that they



are those which, in the author's judgment, will give the best properties with the greatest ease and regularity. At the same time they are steels which are easy to produce.

**Classification of the Alloy Steels.**—The alloy steels may be conveniently classified into groups which will give the mechanical properties indicated below :—

(1) A maximum stress of 100 tons per square inch and over.

(2) A maximum stress of from 75 to 100 tons per square inch.

(3) A maximum stress of from 60 to 75 tons per square inch.

(4) A maximum stress of from 50 to 60 tons per square inch.

(5) A maximum stress of from 40 to 50 tons per square inch.

In dealing with the steels which will satisfy the mechanical properties called for by each of the above classes, it is necessary to take into account the mass of the part. If any of these mechanical properties were to be produced only in sections of steel not more than  $\frac{1}{4}$  inch in diameter, it would be almost unnecessary to use alloy steels at all, since carbon steels, containing only a moderate proportion of carbon, could be made to give, by suitable heat treatment, the maximum stress called for by any of the above classes. Since parts of all sizes have to be considered, it is necessary to consider the effect of mass. When parts of small mass are being referred to in the following sections, a ruling diameter of not more than 2 or 3 inches may be considered as representative. Parts of large mass are those with a ruling diameter of more than 3 inches.

*Class 1.* Steels which will give a maximum stress of 100 tons per square inch, or more, in parts of both large and small mass, and which, at the same time, are commercially easy to produce, are comparatively few. For parts of large mass, the steels must almost inevitably

be of the air-hardening class. These are the only steels which will harden, sufficiently easily and thoroughly, to attain a strength of 100 tons per square inch in the centre of a large part. In small parts, this strength can be obtained from steels which must be hardened either in oil or water, but it should be pointed out that, when steels of this kind are heat treated to produce a high tensile strength, they generally possess comparatively unsatisfactory ductility and notched bar values, whereas the air-hardening steels will give very good values for both these properties. The engineer will be well advised, therefore, to employ air-hardening steels for almost all parts in which he requires a reasonably uniform maximum strength, throughout the mass, of 100 tons per square inch or over.

There are many kinds of air-hardening steels. Steels containing a high proportion of nickel and a moderate proportion of carbon, will harden when cooled in air from a sufficiently high temperature (see p. 56). Steels containing a high percentage of manganese also harden in air. Steels containing a high proportion of chromium and a moderate proportion of carbon will harden in air, whilst high tungsten steels (e.g., high speed steels) are air hardening. The majority of these steels have some disadvantage or other which renders them comparatively useless for most structural engineering purposes, and the type of steel most usually employed for engineering parts in which a high strength is required is that containing both nickel and chromium.

It is desirable to investigate what are the causes of air hardening in some nickel chromium steels. It will be clear from the statements made in Chapter III regarding hardening, that the property of air hardening of nickel chromium, or any other, steel, depends upon the fact that the solid solution formed in that steel at high temperatures remains intact, and does not decompose during the comparatively slow cooling, in air, down to room temperatures. There may be many reasons for

this stability of the solid solution. The first cause may be that the "carbon" change-point, or the lower critical point, which is bound up with the decomposition of the solid solution, is lowered so much by the presence of the alloys that it actually does not occur at any temperature above that of the atmosphere. Obviously, a steel possessing this property would show no tendency to decompose, when cooled in air from a high temperature, because of the low critical point. A second cause which contributes to make steels harden in air, even though their lower critical point may occur at a temperature higher than atmospheric, is the rigidity or viscosity of the solid solution in the steel. It is quite well known that the rigidity of the solid solution is a function of its temperature. The higher the temperature, the less rigid the solid solution will be. As the temperature falls, the solid solution increases in rigidity, and consequently increases in viscosity. The speed of decomposition of a solid solution is necessarily affected considerably by its rigidity or viscosity. The decomposition means that there is some movement of the particles within the solid solution, and the ease with which this movement can take place will be inversely proportional to the viscosity or rigidity of the solid solution. Therefore, although the change of structure associated with the critical point might occur at a temperature higher than atmospheric, it is quite possible that the solid solution may have become so rigid, in consequence of the comparatively low temperature which it has attained, that it is impossible for the movement of the particles which produces the structural change (this being the decomposition of the solid solution) to take place. The accuracy of this view is supported by the known effect of time upon the decomposition of the solid solution in air-hardening nickel chromium steels. Even those nickel chromium steels which harden most violently when cooled in air, i.e., at a normal rate, can be made quite soft, if the steel is cooled so slowly, i.e., over many days, that the ordinary structural changes

have time to proceed to completion. Although the steel, when being cooled in air, does not decompose, it will undergo the normal structural changes associated with the lower critical temperature, if the rate of cooling be made very slow. The influence of the viscosity of the solution is evident in this connection.

In the nickel chromium steels, there is no doubt that

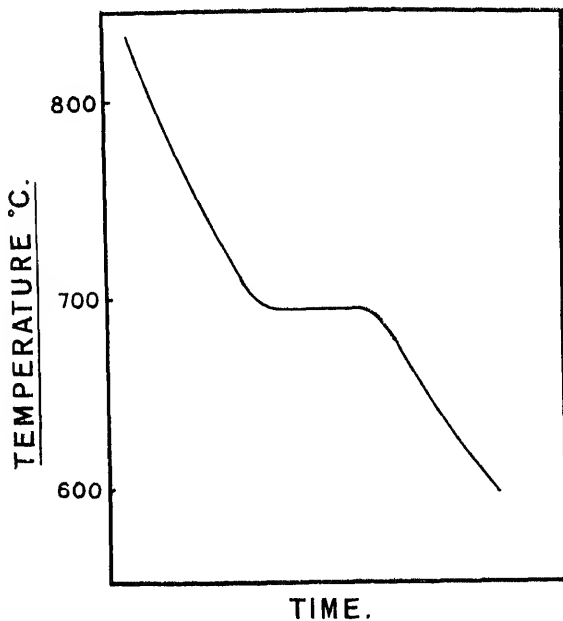

FIG. 60.—TIME/TEMPERATURE COOLING CURVE OF STEEL CONTAINING 0·9 PER CENT. OF CARBON.

the air-hardening properties are due to the fact that the solid solution, which would decompose at some critical temperature above atmospheric, if sufficient time were allowed to it, remains unchanged, in consequence of the viscosity and rigidity which the solid solution has attained when it has cooled down to this critical temperature, and is also due to the fact that, in the ordinary air-hardening

operation, the rate at which the specimen is cooling through the critical temperature is comparatively high.

The air-hardening properties of nickel chromium steels can be attributed more to the effect of the chromium than to the nickel, although both elements necessarily have an effect. In Chapter III, Fig. 26, curves are shown to illustrate the occurrence of the critical points in plain carbon steels. The curves shown in Fig. 26 are inverse rate cooling curves, and show the time taken for the specimen to cool through successive equal ranges of temperature. A simpler form of cooling curve is that shown in Fig. 60, in which the temperature of the steel at any time is plotted against the time occupied in cooling down to that temperature. Such a curve is a plain simple time/temperature curve, and it is clear that, at the critical point, the temperature of the steel remains constant during a more or less lengthy period. In the plain carbon steels, the shape of the time/temperature cooling curve is not affected appreciably by the previous history of the steel, and, in particular, is not affected by the temperature from which the steel under examination originally started to cool. If the steel contains a certain proportion of chromium, this statement does not hold good. In Fig. 61A several time/temperature cooling curves of steels containing a small percentage of chromium are exhibited, the only variation in the treatment of the different samples being the temperature from which the specimen commenced to cool. These curves show that steels containing chromium, when cooled from comparatively high temperatures, are subject to a phenomenon which is a kind of surfusion (or under-cooling). The nature of this surfusion, and its effect, can probably be understood most easily by considering a somewhat simpler material than chromium steel.

In Fig. 62 is shown a time/temperature cooling curve for pure antimony. The flat portion of the curve, BC, represents the comparatively lengthy period during which the metal remains at its true freezing-point. The

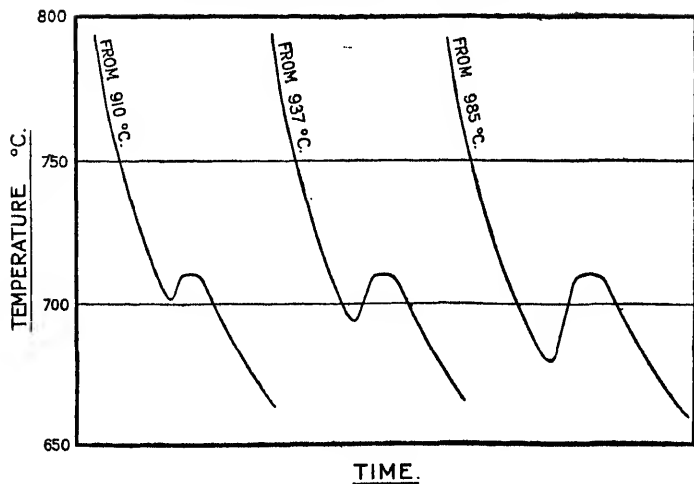

FIG. 61A.—COOLING CURVES OF CHROMIUM STEEL COOLED FROM DIFFERENT TEMPERATURES.

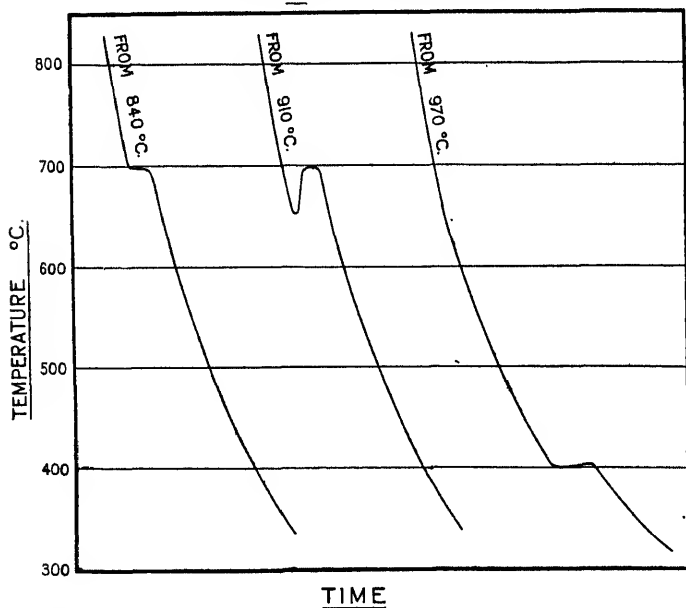

FIG. 61B.—COOLING CURVES OF NICKEL CHROMIUM STEEL (AIR HARDENING) COOLED FROM DIFFERENT TEMPERATURES.

shape of the curve shows, however, that the metal had cooled down to a temperature considerably below its true freezing-point before any freezing actually occurred. The metal has in fact cooled down to a temperature shown by A, which may be  $15^{\circ}$  C. below its actual freezing-point. Immediately upon the commencement of solidification, the temperature of the whole of the metal rises to the

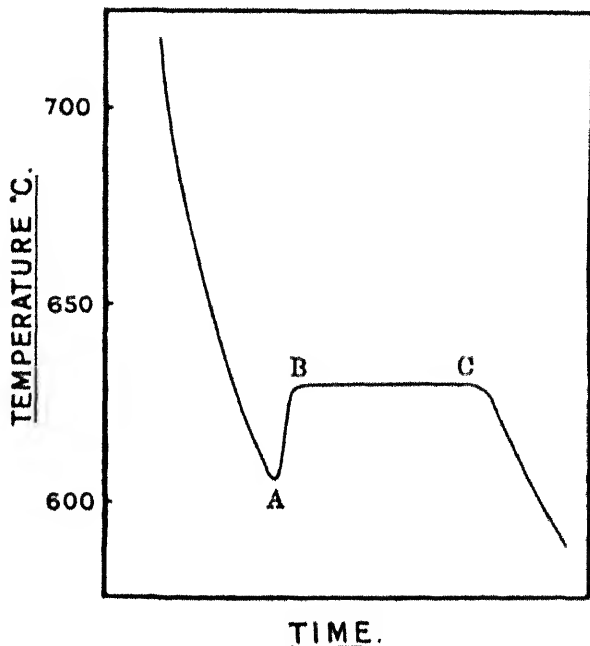

FIG. 62.—COOLING CURVE OF PURE ANTIMONY.

temperature B, which represents the true freezing-point of the metal. A precisely similar thing occurs in the chromium steels. They can be cooled down to a temperature below their normal change-point, without undergoing the decomposition which is customarily associated with that point, though when the change does start, the temperature of the steel mounts up again to the normal critical value. The degree to which surfusion

takes place with the chromium steels, depends to a considerable extent upon the temperature from which the specimen has been cooled, and also depends upon the proportion of chromium in the steel. With steels containing only 2 or 3 per cent. of chromium, it is necessary to heat to quite a high temperature in order to produce any appreciable degree of surfusion. The actual figures are shown in the curves in Fig. 61A. It is evident that the greater the amount of surfusion which has taken place, the greater will be the rigidity and the viscosity of the solid solution in the chromium steels, at that temperature at which surfusion would end, and at which the temperature of the metal would begin to rise. It is easy to appreciate that if the degree of surfusion is large, the rigidity of the solid solution may be so great, that the rise in temperature to the normal critical point, and the decomposition of the solid solution, do not occur, because of the resistance opposed by the high viscosity of the solid solution.

In the plain chromium steels a considerable proportion of that element must be present if this result is to be obtained, or else the steel has to be cooled from a very high temperature. Since the air-hardening steels are not, for the purpose of hardening, cooled from a very high temperature, the full effect of the surfusion must be produced in other ways. One way is to add more chromium. Another way is to add nickel. The nickel in the solid solution, acting together with the chromium, produces a rigid and viscous solid solution. The nickel also tends to depress the temperature of the critical point. It is possible, therefore, by adding nickel to the chromium steels, to produce such a solid solution as does possess the necessary viscosity and rigidity to prevent the steel undergoing its normal decomposition, after it has once been cooled down to the low temperature produced by the surfusion effects of the chromium plus the nickel.

In addition to chromium and nickel the nickel-chromium



the decomposition of the solid solution, formed at high temperatures, and its presence in the air-hardening steels tends to increase the rigidity and viscosity, and, therefore, stability of the solid solution produced in those steels. This fact assists towards the successful carrying out of the air-hardening processes. By the cumulative effect of the addition of nickel and manganese to the chromium steels, it is possible to prevent the occurrence of those changes which correspond to the behaviour of pure antimony, during freezing, indicated by the portion ABC of the curve shown in Fig. 62. When once the temperature of the steel, which corresponds to the temperature A in the freezing of antimony, has been passed during cooling, there is no likelihood of any further alteration taking place, because, if the rigidity of the solid solution was sufficient to prevent the rise of temperature after the surfusion, it is likely to remain sufficiently powerful during the remainder of the cooling, since the rigidity increases as the temperature falls. What has happened, therefore, is really similar to what would happen if it were possible to prevent altogether the rise of temperature of pure antimony from the temperature A. If this could be achieved, then antimony would be procurable as a liquid even at ordinary temperatures. Up to the present this has not been achieved, but a somewhat similar result can be attained from somewhat simpler materials.

It is possible to make a solution of photographic "hypo" (sodium thiosulphate) and to saturate it whilst the solution is boiling. It is also possible, by taking considerable care to keep the solution free from dust and vibration, etc., to allow this solution to cool down to room temperature without the crystallisation of any of the excess hypo, although the solubility of hypo at room temperature is very much less than at the boiling-point. If the process of surfusion does not occur, then the cooling curve of the solution of hypo is very similar to that of antimony as shown in Fig. 62.

The tempering of air-hardening steels naturally proceeds upon somewhat similar lines to the tempering of all other steels. The question is sometimes raised, however, as to why the air-hardening steels do not temper themselves during their own air-hardening process, that is to say, why an air-hardening steel which has been cooled down to normal temperature and then re-heated to 600° C. is soft, whilst the air-hardening steel which has simply cooled down, and has cooled at a normal rate through the temperature of 600° C., is hard. The reason for the difference should be fairly clear from the statements made above. During the original cooling, the solid solution in the steel does not decompose at all, first, because of the surfusion effect, and subsequently because of the induced rigidity of the solid solution. When it is being heated up the conditions are quite different. In the first place, consider what will happen if the solution of hypo previously mentioned is warmed. It is quite well-known that by applying heat to the solution, crystallisation will sooner or later begin, just as it will if the solution is shaken, or if it be sown with dust or crystals. The heating has helped the solution to return to normal conditions. The operation of tempering the hardened steel also facilitates its return to a normal condition. The steel has been undercooled and, therefore, is comparatively unstable. It only requires to be assisted in its return to a more stable condition. This assistance is given by raising the temperature.

From what has been written above, it should be evident that the element which will control the air-hardening properties of the nickel chromium steels is chromium. A certain proportion of that element *must* be present, and it is usual to find that the percentage of chromium in the air-hardening steels is not less than 1.1. An average value is about 1.25 per cent. With this proportion of chromium, it is essential that a reasonable value of manganese be associated, and a range of 0.4 to 0.75 per cent. is customary. The nickel is required in order to

produce the combined surfusion and rigidity effect, and it is usual to have about 4.0 per cent. of that element in the steel. The carbon content is not particularly important, provided that it is not too low, and proportions between 0.25 to 0.35 per cent. are found almost indiscriminately. A typical composition, and a fair range showing limiting values, would be as follows :—

	TYPE.	RANGE.
Carbon .. ..	0.30	0.25 to 0.35 per cent.
Chromium .. ..	1.25	1.1 to 1.5 ..
Nickel .. ..	4.25	3.75 to 4.75 ..
Manganese .. ..	0.45	0.40 to 0.75 ..

As regards the range of values, it is not suggested that the minimum proportions of all the elements would give the desired results. The values indicate the extremes within which it is possible to have a suitable combination of the constituents, and to procure the desired result.

The hardening of these steels is effected by heating to a temperature of about 820° C., followed by cooling in still air. Cooling in an air blast gives no better results, and quenching in oil or water produces practically no increase of tensile strength, if the steel is of a really air-hardening composition.

The use of such methods of cooling may, in fact, be comparatively dangerous, because of the severe contraction and expansion forces produced during hardening. It may be taken as a general rule, that steel should always be cooled at the slowest rate compatible with the production of the required maximum strength. Since the nickel chromium air-hardening steels will give the required strength by cooling in air, it is futile to employ any other method of treatment. The mechanical properties which are obtained in steels of this class after

TABLE 32.

MECHANICAL PROPERTIES OF AIR-HARDENING STEELS AFTER COOLING IN AIR AND IN OIL.

Steel.	Heat Treatment.	Max. Stress, tons per sq. in.	Elongation, %.	Impact, ft.-lb.
1	Air hardened 820° C.	114	12	15
1	Oil hardened 820° C.	116	11	13
2	Air hardened 830° C.	110	13	17
2	Oil hardened 830° C.	112	13	16

These results demonstrate clearly, that oil hardening produces no superiority in the mechanical properties of the steel over those produced by air hardening.

It is evident that after rolling, after forging, and after stamping, the air-hardening steels are bound to be quite hard. All these operations must be carried out at a temperature higher than the hardening temperature of the steel, and the steel is usually allowed to cool in the air after they have been completed. Steel of 100 tons per square inch tensile strength is of such a hardness that it cannot be machined, except with the utmost difficulty, and for general engineering purposes it may be considered unmachinable. In order to utilize the air-hardening nickel chromium steels in ordinary engineering practice, they must be heat treated, after they have been submitted to any of the above processes, in such a manner that they are softened to a strength at which they can be machined in comfort. This softening cannot be carried out by normalising (see p. 69), and must be effected in another way. The only practical method of softening the air-hardening steels is to temper them. The mechanical properties of a typical nickel chromium air-hardening steel, after tempering, are shown in Table 33 and also in Fig. 63.

TABLE 33.

SHOWING THE MECHANICAL PROPERTIES OF A STEEL CONTAINING

CARBON .. .. .	0.31 per cent.
MANGANESE .. .. .	0.41 ,,
NICKEL .. .. .	3.9 ,,
CHROMIUM .. .. .	1.37 ,,

AFTER HARDENING AND TEMPERING.

*(Diameter of specimens at time of heat treatment—1 inch.)*

Heat Treatment.	Max. Stress, tons per sq. in.	Elongation, %.	Impact, ft.-lb.
Air hardened 820° C. tempered — ..	115	12	15
Air hardened 820° C. tempered 200° C. ..	111	13	15
Air hardened 820° C. tempered 300° C. ..	107	13	11
Air hardened 820° C. tempered 400° C. ..	93	15	14
Air hardened 820° C. tempered 500° C. ..	79	16	32
Air hardened 820° C. tempered 600° C. ..	62	23	63
Air hardened 820° C. tempered 650° C. ..	59	26	72

The test figures in Table 33 indicate that if the steel is tempered at a temperature of about 650° C., the maximum strength of the steel has fallen to approximately 60 tons per square inch. This is the condition, i.e., tempered at 650° C., in which the steel should be delivered to the machine shop. It is usually quite possible to soften 100-ton steel so that it gives a Brinell hardness number of not more than 269, and it will meet all ordinary machining requirements, if this figure is specified as the limit above which the steel should not be delivered to the machine shop. It is evident that all the machining operations on these steels must be carried out before the steel is hardened. The only mechanical operation which can be performed satisfactorily after hardening is grinding. Contrary, therefore, to the general practice, parts made from air-hardening steel should be machined from the softened steel very nearly to size, leaving only a small

grinding allowance. The parts can then be hardened in air and ground to size.

It is frequently found that if the 100-ton air-hardening nickel chromium steels are heated to a temperature of 175° C. they suffer no notable loss of strength, but that

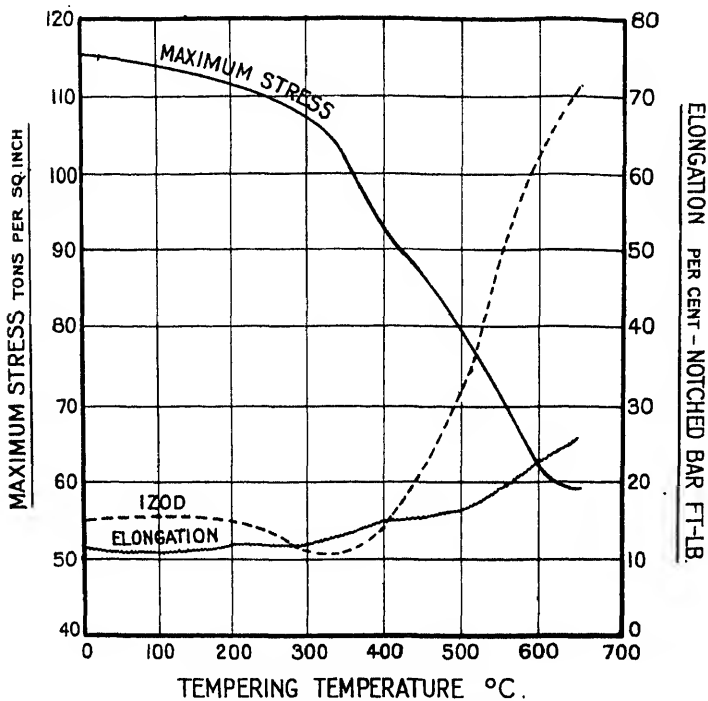

FIG. 63.—THE EFFECT OF TEMPERING AT DIFFERENT TEMPERATURES UPON THE MECHANICAL PROPERTIES OF 100-TON AIR-HARDENING NICKEL CHROMIUM STEEL

the ductility and notched bar values of the steels are improved appreciably. This fact is of some value, and many steelmakers recommend that this treatment should be given to their steels. The treatment is quite good, and nothing can be urged against it. In addition to improving the ductility and notched bar values, such a

grinding allowance. The parts can then be hardened in air and ground to size.

It is frequently found that if the 100-ton air-hardening nickel chromium steels are heated to a temperature of 175° C. they suffer no notable loss of strength, but that

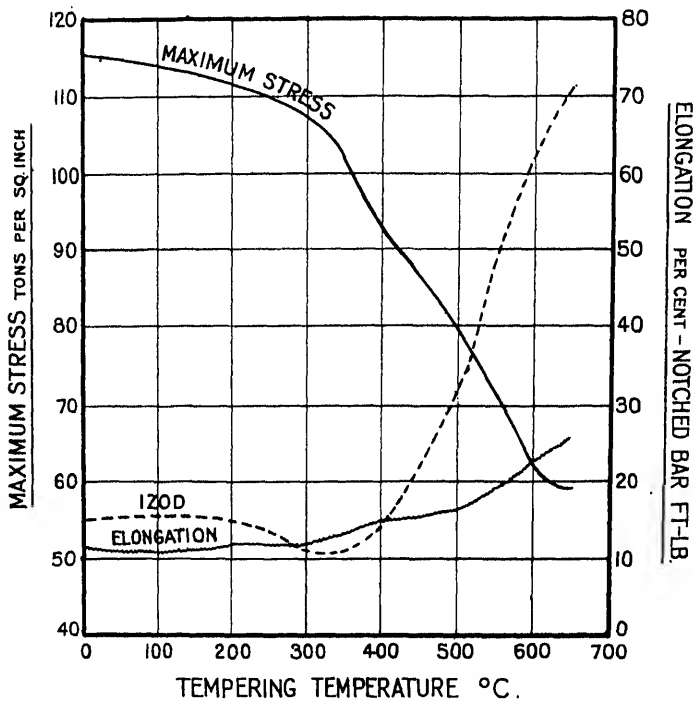

FIG. 63.—THE EFFECT OF TEMPERING AT DIFFERENT TEMPERATURES UPON THE MECHANICAL PROPERTIES OF 100-TON AIR-HARDENING NICKEL CHROMIUM STEEL

the ductility and notched bar values of the steels are improved appreciably. This fact is of some value, and many steelmakers recommend that this treatment should be given to their steels. The treatment is quite good, and nothing can be urged against it. In addition to improving the ductility and notched bar values, such a

treatment tends to remove a certain proportion of the strains which are necessarily locked up in the steel as a result of the hardening operation. If tempering at 175° C. be carried out on the steel, the operation should take place prior to the final grinding.

*Class 2.* The steels to be used for parts requiring a maximum strength of from 75 to 100 tons per square inch, depend upon the mass of the part. If the parts are large, an air-hardening steel should certainly be employed. Such a steel is the one described for Class 1, and it should be tempered at temperatures varying from 200° C. to 550° C, according to the actual maximum stress required, whether near to 100 tons or to 75 tons per square inch. If the parts are small, it is possible to employ a steel which should be hardened in oil. As for Class 1, a nickel chromium steel gives by far the most satisfactory results, and the class of nickel chromium steel which is likely to prove most satisfactory has a composition approximately as follows :—

Carbon .. ..	0.30 to 0.36	per cent.
Nickel .. ..	3.25 to 3.75	„
Chromium .. ..	0.8 to 1.2	„
Manganese .. ..	0.4 to 0.7	„

This steel will give quite good mechanical properties, after quenching in oil from a temperature of about 830° C., provided that the mass at the time of hardening is reasonably small. In Table 34 and Fig. 64 are shown the mechanical properties of a typical steel of this class, after hardening and tempering.

A reference to Tables 33 and 34, and Figs. 63 and 64, will show that it is possible to select a steel, and to treat it in such a way that it gives any required tensile strength from 75 to 100 tons. These results also show, however, that the notched bar values are not at all good in the steels which have been tempered at the low temperatures necessary for the production of these high strengths.



TABLE 34.

SHOWING THE MECHANICAL PROPERTIES OF A STEEL CONTAINING

CARBON	..	..	..	..	0.32 per cent.
MANGANESE	..	..	..	..	0.48 "
NICKEL	..	..	..	..	3.37 "
CHROMIUM	..	..	..	..	0.93 "

AFTER HARDENING AND TEMPERING.

*(Diameter of specimens at time of heat treatment—1½ inches.)*

Heat Treatment.	Max. Stress, tons per sq. in.	Elongation, %.	Impact, ft.-lb.
Oil hardened 820° C., tempered — ..	114	13	12
Oil hardened 820° C., tempered 300° C. ..	96	13	5
Oil hardened 820° C., tempered 400° C. ..	83	14	7
Oil hardened 820° C., tempered 500° C. ..	73	17	35
Oil hardened 820° C., tempered 600° C. ..	63	21	55
Oil hardened 820° C., tempered 650° C. ..	59	23	67
Oil hardened 820° C., tempered 700° C. ..	71	13	29
Oil hardened 820° C., tempered 725° C. ..	110	4	12

The curve shown in Fig. 64 indicates rather more clearly than the curve shown in Fig. 63, that the impact values of nickel chromium steels which have been tempered at temperatures between 200° C. and 400° C. are comparatively low. It is usually found that the impact value of a hardened steel rises after tempering at temperatures lower than 175° C., and that the value then falls off distinctly with a further rise of tempering temperature, and does not recover until a temperature of 350° C. has been exceeded. It does not always recover until a temperature of 450° C. has been passed. The brittleness induced in nickel chromium steels by tempering at low temperatures has not been explained up to the present. A somewhat similar drop in toughness occurs in the carbon steels, and, in fact, is found in almost every steel, but, so far, the reason for the deterioration has not been discovered.

The steels for Class 2 require to be softened for machining, just as those for Class 1 must be so treated. It is not possible to machine, with any ease, steels which have a maximum stress of more than 75 tons. Therefore, the machining should be done upon the steel when it is in its softest condition, and the heat treatment carried out

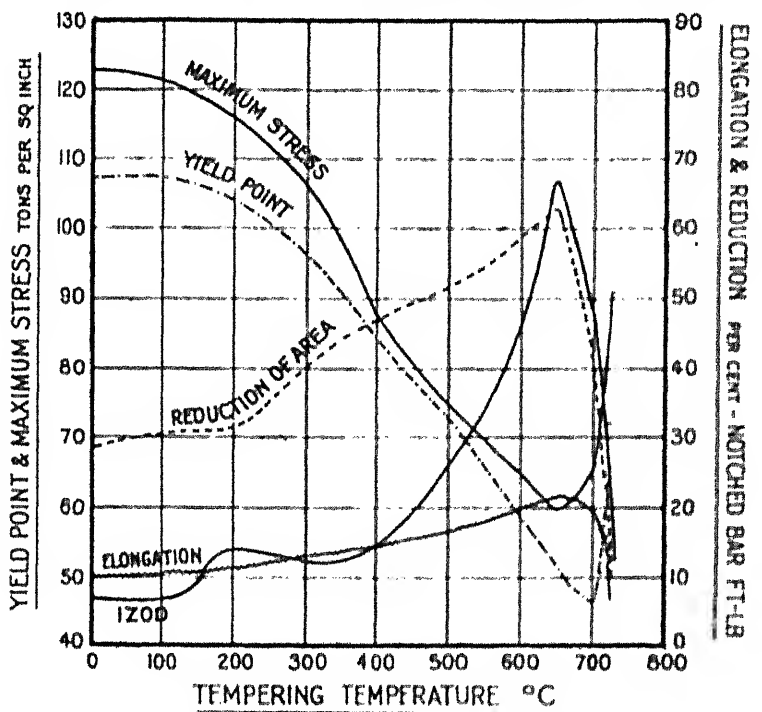

FIG. 64.—THE EFFECT OF TEMPERING AT DIFFERENT TEMPERATURES UPON THE MECHANICAL PROPERTIES OF OIL-HARDENING NICKEL CHROMIUM STEEL.

after almost the whole of the machining has been completed. The most satisfactory way of softening the steel is to harden it, either in oil or in air, and then to temper it at a temperature of about 650° C.

*Class 3.* Steels which can be used to give a maximum strength of from 60 to 75 tons are more numerous than

those suitable for either of the two classes already considered. It is obvious, from what has been shown above of the mechanical properties of the air-hardening and the oil-hardening nickel chromium steels quoted above, that either of these steels could be employed to provide the range of mechanical properties required in

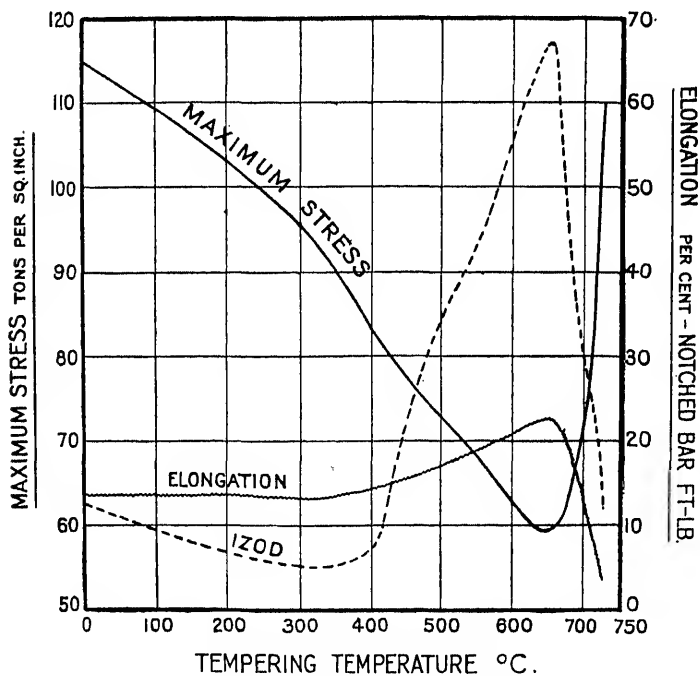

FIG. 65.—THE EFFECT OF TEMPERING AT DIFFERENT TEMPERATURES UPON THE MECHANICAL PROPERTIES OF OIL-HARDENING NICKEL CHROMIUM STEEL.

the present class. If the parts are very large, then there is little doubt that the use of air-hardening steel will give the most satisfactory results. If the mass is only moderately large, then the oil-hardening nickel chromium steel proposed for Class 2 would give equally satisfactory results, after tempering at suitably high temperatures.

For parts of ordinary size, quite satisfactory results, however, can be obtained from the use of a somewhat softer steel, that is, a steel containing rather less chromium than is found in either of the two previous steels. A suitable range of composition would be approximately as follows:—

Carbon	..	..	0.30 to 0.36	per cent.
Nickel	..	..	3.0 to 3.5	„
Chromium	..	..	0.5 to 1.0	„
Manganese	..	..	0.4 to 0.7	„

This steel gives perfectly satisfactory mechanical properties, after quenching in oil from a temperature of about 830° C. and tempering at temperatures in the region of 500° C. A complete résumé of the mechanical properties of this steel, after hardening and tempering, is given in Table 35, and is also shown in Fig. 65.

TABLE 35.

SHOWING THE MECHANICAL PROPERTIES OF A STEEL CONTAINING

CARBON	..	..	..	..	0.31	per cent.
MANGANESE	..	..	..	..	0.45	„
NICKEL	..	..	..	..	3.41	„
CHROMIUM	..	..	..	..	0.78	„

AFTER HARDENING AND TEMPERING.

(Diameter of specimens at time of heat treatment—1½ inches.)

Heat Treatment.	Max. Stress, tons per sq. in.	Elongation, %.	Impact, ft.-lb.
Oil hardened 830° C., tempered — ..	110	13	11
Oil hardened 830° C., tempered 300° C. ..	91	14	6
Oil hardened 830° C., tempered 400° C. ..	80	15	10
Oil hardened 830° C., tempered 500° C. ..	69	18	38
Oil hardened 830° C., tempered 600° C. ..	59	23	59
Oil hardened 830° C., tempered 650° C. ..	56	25	71

The steels for Class 3 may be softened, when necessary for machining, in the same way as the steels for Class 2

The nickel chromium steels suitable for Class 3, when treated to give a strength between 60 and 75 tons per square inch, introduce, for the first time, a difficulty which is always met with in connection with the production of a suitable toughness value in nickel chromium steel. Class 3 steel is usually tempered at a temperature near to 550° C., if a strength anywhere near to 70 tons per square inch is required (see Table 35 and Fig. 65). It is found that if nickel chromium steels are tempered at temperatures near to 550° C. and then cooled in air (which, in the past, has always been the normal method of cooling steels after tempering), a very poor toughness value is obtained, that is to say, the notched bar value is exceedingly low.

It is possible, however, to overcome this defect by cooling the steels from their tempering temperature quickly—by quenching in water—provided that they are not tempered within certain ranges of temperature. The figures given below will show that even this process will not improve the toughness values, if the steels are tempered at a temperature between 450° C. and 550° C.

TABLE 36.

SHOWING NOTCHED BAR VALUES OF A NICKEL CHROMIUM STEEL  
COOLED QUICKLY, AND SLOWLY, AFTER TEMPERING.

(Diameter of specimens at time of heat treatment—1½ inches.)

Tempering Temperature° C.	Max. Stress, tons per sq. in.	Notched Bar Value, ft.-lbs.	
		Cooled in Water after Tempering.	Cooled in Air after Tempering.
—	117	9	9
100	117	11	11
200	114	17	17
300	106	9	9
400	95	8	8

The phenomenon of the poor toughness of nickel chromium steels which have been tempered at temperatures higher than  $400^{\circ}\text{C}$ ., is known as "temper brittleness" or "Krupp Krankheit," and it may be well at this stage to give some short account of it. As stated above, the only effect of temper brittleness is to reduce the notched bar value of the steel. This effect can be clearly seen from the figures given in Table 36, which includes not only the notched bar values obtained upon the steel which, after tempering, has been cooled slowly, but also the notched bar values upon a similar portion of the same piece of steel after it has been cooled quickly.

The figures in Table 36 show a difference in the notched bar values obtained after the two types of heat treatment, in the specimens which have been tempered above a certain definite temperature. If careful tests are made, it is found that all the other properties of the steel, i.e., elastic limit, yield-point, maximum stress, fatigue range, elongation per cent., reduction of area per cent., electrical conductivity, specific heat, etc., etc., are not in any way affected by the different methods of cooling. Only the toughness or notched bar value is changed by cooling quickly. Microscopic examination of two specimens, one cooled quickly and the other cooled slowly, i.e., one having a high, and the other a low, notched bar value, reveals absolutely no difference whatever in the microstructure. As stated on p. 125, the speed of fracture has no influence upon the results, since slowly bent notched specimens of tough and of temper-brittle steel give the same relative notched bar values as are obtained from similar specimens broken in a normal impact testing machine.

The precise causes of the production of temper brittleness are not known, but the following facts are known, and are sufficient for the use of the engineer.

- (1) That after tempering within a certain range of temperature (usually about  $425^{\circ}\text{C}$ . to  $550^{\circ}\text{C}$ .) nickel

chromium steels give a definitely low notched bar value.

(2) That whatever method of cooling is employed for steels tempered in the above range, the notched bar value is low (see Table 37).

TABLE 37.

SHOWING THE EFFECT OF DIFFERENT METHODS OF COOLING, FROM VARIOUS TEMPERATURES, UPON THE NOTCHED BAR VALUE OF A NICKEL CHROMIUM STEEL.

Method of Cooling.	Tempering Temperature.	Impact Value, ft.-lb.
In Furnace .. .. .	650° C.	7, 7, 6
In Air .. .. .	650° C.	15, 16, 19
In Oil .. .. .	650° C.	42, 44, 47
In Water .. .. .	650° C.	52, 56, 56
In Furnace .. .. .	550° C.	6, 6, 5
In Air .. .. .	550° C.	7, 7, 9
In Oil .. .. .	550° C.	11, 10, 11
In Water .. .. .	550° C.	11, 6, 13
In Furnace .. .. .	450° C.	19, 20, 18
In Air .. .. .	450° C.	28, 32, 33
In Oil .. .. .	450° C.	31, 32, 35
In Water .. .. .	450° C.	26, 25, 20

(3) That specimens tempered at temperatures higher than 550° C. may give low notched bar values if cooled slowly (see Table 37).

(4) That this low notched bar value can be avoided by cooling the specimens rapidly from the tempering temperature (see Table 37).

(5) That all nickel chromium steels do not show the symptoms associated with temper brittleness, and that others show them only partially. This is clearly indicated by the figures given in Table 38, which show the ratio between the toughness value of specimens of the same steel cooled quickly and slowly, this ratio having been termed by Brearley the "Coefficient of Krupp Krankheit."

TABLE 38.

SHOWING THE SUSCEPTIBILITY OF DIFFERENT NICKEL CHROMIUM STEELS TO TEMPER BRITTLENESS.

Carbon, %.	Nickel, %.	Chromium, %.	Izod Values.		Susceptibility, 1:2.
			(1) Water Cooled.	(2) Furnace Cooled.	
0.33	3.71	0.91	46, 48, 49	6, 4, 3	12.5
0.29	3.81	0.90	50, 51, 50	8	6.3
0.30	3.44	1.27	48	14, 12	3.7
0.32	3.75	0.94	21, 24	7	3.3
0.36	3.62	0.96	31, 40	11	3.2
0.30	3.61	1.03	47	20, 12	3.0
0.36	3.79	0.95	40	17, 9	3.0
0.29	3.81	1.51	35, 32	15	2.3
0.30	3.71	0.94	53	20, 26	2.3
0.34	3.77	0.95	43	20	2.2
0.33	3.63	1.01	30, 30	16	1.9
0.38	3.44	1.73	37, 41	23	1.7
0.33	3.67	0.85	35, 33	20	1.7
0.35	3.68	0.91	42	33, 31	1.3
0.32	3.43	0.88	60, 56, 54	72, 72	0.7
0.30	3.64	1.15	40	53, 51, 53	0.77
0.38	3.56	1.11	32, 31	43	0.75

In view of the great variation in susceptibility, it is of course possible to obtain perfectly good toughness values from steels which have not been cooled quickly after tempering, but since it is only possible to determine the coefficient of Krupp Krankheit by actual experiment, it is safer to assume that all nickel chromium steels will be brittle, unless they are cooled rapidly after tempering, and, therefore, to adopt rapid cooling in all cases.

(6) The avoidance of temper brittleness is a function of the rate of cooling of the steel. The rate of cooling depends upon the mass of the steel part (see p. 71). The rate of cooling in air, of a thin piece of steel, may be equal to the rate of cooling in oil, or in water, of a piece of steel of much larger mass. Discretion should,



therefore, be employed in the method adopted for the cooling of the tempered steel, the action dictated by this discretion being based upon an estimate of the mass of the part. Almost the only objection which can be urged against the practice of quenching after tempering, is that it tends to make the scale, on drop forgings and forgings so treated, distinctly more difficult to remove during machining.

Unless a definite statement is made to the contrary, it can be assumed that all the notched bar values of nickel chromium steels quoted in this book have been obtained upon specimens cooled rapidly after tempering.

*Class 4.* The steels which will give a maximum strength of 50 to 60 tons are more numerous than those which will provide the higher strengths dealt with in the previous sections. This makes it all the more important that the steel used should be selected wisely. The importance of this class of steel is increased by the fact that 60 tons per square inch represents the upper limit of tensile strength for steels which are to be reasonably easy to machine. When this fact is coupled with the other fact that, probably, more alloy steel parts are made to a strength between 50 and 60 tons per square inch than to any other range of strength, the importance of a satisfactory selection of steel becomes still greater.

The air-hardening steel suitable for Class 1 is really not satisfactory for parts of 50 to 60 tons maximum strength. The 100-ton steel can generally only be reduced to a strength of about 58 tons per square inch, even after tempering at the highest possible temperature. The oil-hardening steel suggested for Class 2 can be tempered to a little lower strength, whilst the oil-hardening steel suitable for Class 3 can be heat treated to meet the requirements of Class 4 fairly well, as can be seen easily from the figures given in Table 35. Still better results

of carbon. The following composition would give satisfactory results.

Carbon .. ..	0.27 to 0.33	per cent.
Nickel .. ..	3.0 to 3.5	„
Chromium .. ..	0.5 to 0.8	„
Manganese .. ..	0.4 to 0.75	„

The complete properties of this steel after hardening and tempering are given in Table 39.

TABLE 39.

SHOWING THE MECHANICAL PROPERTIES OF A STEEL CONTAINING

CARBON .. ..	0.29	per cent.
MANGANESE .. ..	0.63	„
NICKEL .. ..	3.28	„
CHROMIUM .. ..	0.68	„

AFTER HARDENING AND TEMPERING.

(Diameter of specimens at time of heat treatment— $1\frac{1}{8}$  inches.)

Heat Treatment.	Max. Stress, tons per sq. in.	Elongation, %.	Impact, ft.-lb.
Oil hardened 830° C. tempered — ..	118.0	11.8	7
Oil hardened 830° C. tempered 300° C. ..	101.3	14.0	3
Oil hardened 830° C. tempered 400° C. ..	83.6	14.8	14
Oil hardened 830° C. tempered 500° C. ..	71.6	18.2	24
Oil hardened 830° C. tempered 600° C. ..	62.0	21.6	47
Oil hardened 830° C. tempered 650° C. ..	55.2	23.6	70

Another steel which gives satisfactory results when tempered to a maximum strength of from 50 to 60 tons per square inch is one which contains less nickel than any of the nickel chromium steels so far described. The usual range of composition for this steel is as follows:—

Carbon .. ..	0.28 to 0.40	per cent.
Nickel .. ..	1.2 to 1.8	„
Chromium .. ..	1.0 to 1.5	„

This steel is prone to suffer from mass effect in hardening to a greater degree than steels containing a higher proportion of nickel. The steel does not harden very definitely in air, and, therefore, cannot be recommended for parts of large mass, neither is it really suitable for parts requiring a tensile strength greater than 60 tons. For ordinary-sized parts of between 50 and 60 tons tensile strength the steel is quite good. The mechanical properties of the steel, after hardening and tempering at various temperatures, can be seen clearly from the test results given in Table 40 and Fig. 66. The mass effect in the hardening of this steel is dealt with below.

TABLE 40.

SHOWING THE MECHANICAL PROPERTIES OF A STEEL CONTAINING

CARBON	..	..	..	0.35 per cent.
MANGANESE	..	..	..	0.57 "
NICKEL	..	..	..	1.57 "
CHROMIUM	..	..	..	1.18 "

AFTER HARDENING AND TEMPERING.

*(Diameter of bars at time of heat treatment—1½ inches.)*

Heat Treatment.	Max. Stress, tons per sq. in.	Elongation, %.	Impact, ft.-lb.
Oil hardened 850° C. tempered — ..	126	1	3
Oil hardened 850° C. tempered 200° C. ..	122	7	3
Oil hardened 850° C. tempered 300° C. ..	115	10	10
Oil hardened 850° C. tempered 400° C. ..	104	12	14
Oil hardened 850° C. tempered 500° C. ..	79	14	16
Oil hardened 850° C. tempered 600° C. ..	61	22	48
Oil hardened 850° C. tempered 650° C. ..	56	23	64

Another steel which can be used effectively for parts requiring between 50 and 60 tons ultimate strength is one free from nickel but containing a higher proportion of carbon and of chromium than the alloy steels previously mentioned. This steel is a chromium steel or chromium

vanadium steel, and, as usually made, has approximately the following composition :

Carbon .. .. .	0.40 to 0.50	per cent.
Chromium .. .. .	1.10 to 1.50	„
Vanadium .. .. .	0.15 to 0.20	„

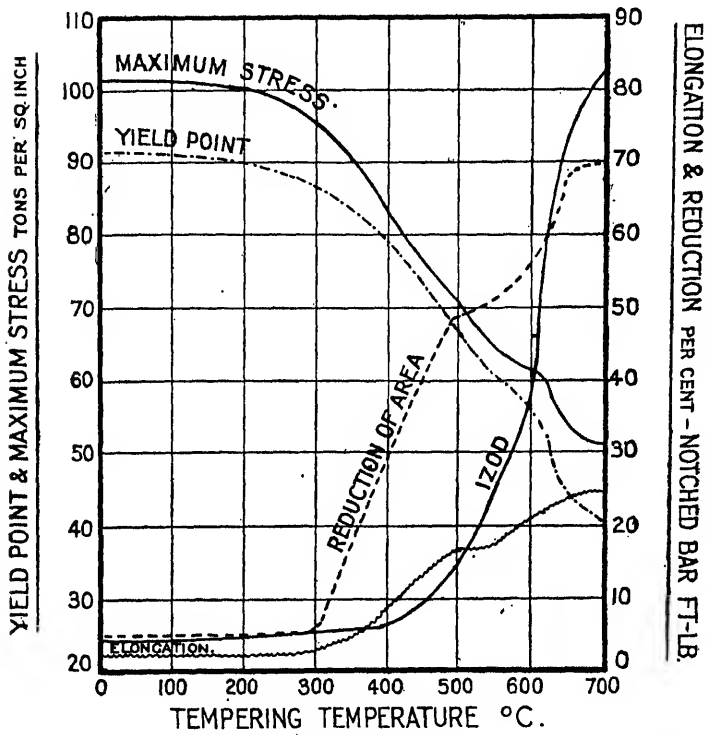

FIG. 66.—THE EFFECT OF TEMPERING AT DIFFERENT TEMPERATURES UPON THE MECHANICAL PROPERTIES OF OIL-HARDENING NICKEL CHROMIUM STEEL CONTAINING A LOW PROPORTION OF NICKEL.

The element in this steel which has the greatest effect upon the mechanical properties is undoubtedly the carbon, and unless it is present in approximately the proportion indicated above, difficulty may be experienced in obtaining a satisfactory combination of strength and toughness in

the heat-treated steel. The actual content of vanadium is not of supreme importance, and, so far as mechanical tests are concerned, just as good results are obtained if the vanadium is omitted altogether, and a plain chromium steel is used. The chromium or chromium vanadium steel does not harden when cooled in air from the ordinary

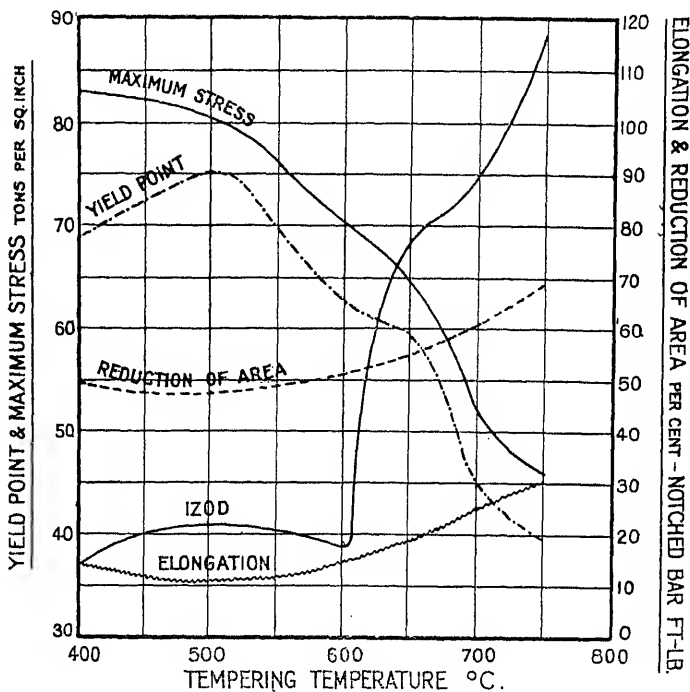

FIG. 67.—THE EFFECT OF TEMPERING AT DIFFERENT TEMPERATURES UPON THE MECHANICAL PROPERTIES OF CHROMIUM VANADIUM STEEL.

heat treatment temperatures, and, therefore, is particularly prone to suffer from the effect of mass during hardening. Consequently, when parts of any large mass are to be made in this steel, it is desirable that a reasonably high proportion of carbon should be present. The mechanical properties of a chromium vanadium steel after hardening

and tempering are shown in Table 41 and Fig. 67, whilst in Fig. 68 are shown the mechanical properties of a similar steel containing no vanadium.

TABLE 41.

MECHANICAL PROPERTIES AFTER HARDENING AND TEMPERING  
OF STEEL CONTAINING

CARBON	..	..	..	..	0.42 per cent.
MANGANESE	..	..	..	..	0.75 ,,
CHROMIUM	..	..	..	..	1.04 ,,
VANADIUM	..	..	..	..	0.15 ,,

ALL THE SPECIMENS WERE QUENCHED IN OIL FROM 870° C.

(Diameter of specimens at time of heat treatment— $1\frac{1}{8}$  inches.)

Tempering Temperature ° C.	Max. Stress, tons per sq. in.	Elongation, %.	Impact, ft.-lb.
400	83.0	13.5	16
500	80.9	11.0	22
600	70.5	15.0	19
650	65.0	18.7	77
700	52.2	25.5	90
750	46.2	30.5	117

*Class 5.* For parts which require a maximum strength in the steel between 40 and 50 tons per square inch it is not usual to employ nickel chromium steels, since most of them have too high a proportion of carbon to allow of them being softened commercially below 50 tons per square inch. But it is not impossible to produce a nickel chromium steel which can be tempered down to a strength of less than 50 tons per square inch. A fairly large quantity of steel has been used for various purposes, containing round about 0.20 per cent. of carbon and a lower proportion of chromium than was specified for the steels already described. Such a steel was frequently employed by the continental, and particularly the German, engineers, but has rarely been used in this country. In reality, it is almost a case-hardening steel—in fact, a

good deal of it has been used for that purpose. If strengths below 50 tons per square inch are required, and an alloy steel is to be used in order to obtain a superior toughness, a chromium or chromium vanadium steel can be used, similar to that described for Class 4, but having

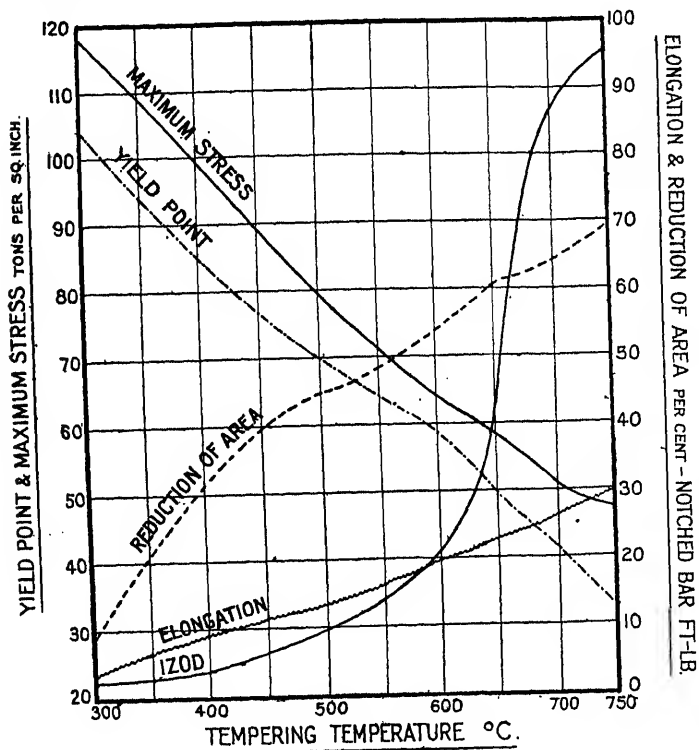

FIG. 68.—THE EFFECT OF TEMPERING AT DIFFERENT TEMPERATURES UPON THE MECHANICAL PROPERTIES OF CHROMIUM STEEL.

a carbon content rather lower than that shown to be suitable for that class. A steel which can be used very easily, and with very good results for Class 5, is a plain nickel steel, containing about 2.5 to 3.5 per cent. of nickel. This is not an air-hardening steel, but hardens

very satisfactorily in oil, and gives good results. A typical range of composition for the steel is as follows :

Carbon .. ..	0.25 to 0.35 per cent.
Manganese .. ..	0.40 to 0.70 ,,
Nickel .. ..	2.5 to 3.5 ,,
Chromium .. ..	not more than 0.30 per cent.

If such a steel is hardened in oil, and then tempered, a very satisfactory range of strength can be produced, whilst at the lower strengths the toughness values given by the steel are quite excellent. Typical test figures are given in Table 42.

TABLE 42.

SHOWING THE MECHANICAL PROPERTIES OF A STEEL CONTAINING

CARBON .. ..	0.35 per cent.
MANGANESE .. ..	0.58 ,,
NICKEL .. ..	3.51 ,,

AFTER HARDENING AND TEMPERING.

(Diameter of specimens at time of heat treatment— $1\frac{1}{8}$  inches.)

Heat Treatment.	Max. Stress, tons per sq. in.	Elongation, %.	Impact, ft.-lb.
Oil hardened 860° C., tempered — ..	105	11	9
Oil hardened 860° C., tempered 300° C. ..	92	13	6
Oil hardened 860° C., tempered 400° C. ..	76	16	10
Oil hardened 860° C., tempered 500° C. ..	62	21	48
Oil hardened 860° C., tempered 600° C. ..	53	25	69
Oil hardened 860° C., tempered 650° C. ..	48	28	84

**General Properties of Alloy Steels.**—The above detailed description of the most suitable alloy steels which are available for the engineer, has shown the range of mechanical properties that can be obtained from this type of steel. With this information to hand, the engineer should be in a position to pick out the kind of steel that will meet almost any requirement which he may have to satisfy. The classification of the steels has been effected upon the



basis of the ultimate strength required in the material used for the various parts. It was stated in the chapter on Mechanical Testing that the toughness of the steel, as measured by the notched bar test, varies more or less inversely as the ultimate strength of the steel, that is to say, that a satisfactory toughness value for a 100-ton

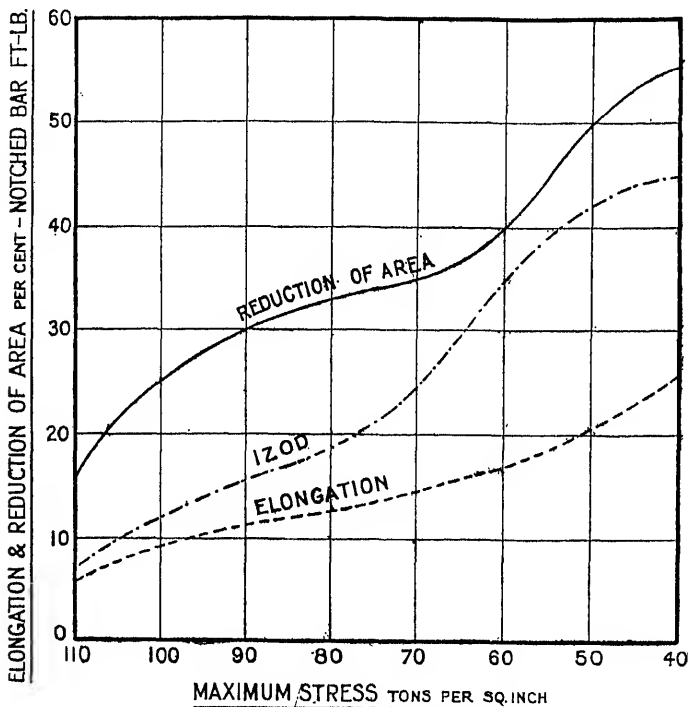

FIG. 69.—TYPICAL VALUES OF TOUGHNESS AND DUCTILITY OF ALLOY STEELS OF DIFFERENT TENSILE STRENGTH.

steel would be very much lower than an equally satisfactory toughness value for a 40-ton steel. To enable the engineer to select what may be considered as specification values of toughness, the curve shown in Fig. 69 indicates the notched bar value which can be considered good and sound for any particular ultimate strength

between 40 and 110 tons per square inch. In the same figure are shown the elongation and reduction of area values, i.e., the ductility measures, which, likewise, can be expected from steels of varying strengths. From the values given in Fig. 69, it is considered that suitable specifications for the alloy steels of varying strengths can easily be drawn up.

**Chemical Composition.**—At the commencement of this chapter, an emphatic statement was made to the effect that the real need of the engineer is, that the steel which he uses shall possess certain values of tensile strength and toughness, and not a particular proportion of nickel or chromium or vanadium. The chemical composition is the means to an end, but it is not the end. It is well to note, however, that after the engineer has made his choice of any particular alloy steel, upon the basis of the mechanical tests which it will give, close attention paid to the chemical composition of the steel is very remunerative. The value of carefully controlled chemical analysis can be illustrated in several ways.

The production of large numbers of any particular article, or even the successful handling of a moderately large series of similar parts, depends for its success upon constancy of properties. The constancy of mechanical properties can be secured by rigorous testing, but this testing can be made simpler and lighter if regularity in the material is ensured by other means. It was shown above that for parts requiring a tensile strength of from 50 to 60 tons, at least three different steels could be employed. (As a matter of fact, many more steels could be suggested, but, in the author's opinion, those indicated are probably the most satisfactory, and are the ones most likely to be employed.) A reference to the tables of mechanical properties produced in these different steels by variations of the heat treatment, shows that a slightly different heat treatment must be given to each of the

different composition are supplied to a works for the manufacture of the same article, an unnecessary strain is put upon the heat treatment department, since this department has necessarily to treat each steel separately, and to vary the heat treatment accordingly. The only way to avoid completely this separation of steels and treatment, is to specify reasonably close limits of chemical composition for the steel for a particular part, and to enforce them as rigorously as possible. Other things being equal, two bars of alloy steel of approximately the same chemical composition can be heat treated in the same manner in order to produce the same mechanical properties, and the same temperatures of hardening and tempering can be employed. The existence of such conditions of uniformity of composition undoubtedly helps considerably in the successful production of machined parts in an engineering works.

A second way in which varying chemical composition adversely affects the production of machined parts arises from the fact that steels of different chemical composition, although of approximately the same physical properties, appear not to machine with the same degree of ease. The reason for this difference is obscure, but there can be little doubt that it exists. The machining property of a steel is not necessarily fixed by its ultimate strength, or its Brinell hardness, or its scleroscope hardness, although, of course, these properties have some considerable influence upon the results obtained. Since the chemical composition of a steel does affect its machining properties to a greater or less degree, it is decidedly better (particularly where automatic machines are being employed), to run upon a material of constant composition.

A third way in which attention to chemical composition is of importance is connected with the production of drop forgings. It is a recognised fact, that steels of different composition behave in different ways under the drop hammer, and that a temperature and rate of forging

when applied to another steel. The mixing of steels for any particular part invariably means an increased waste during stamping, and to the drop-forging regularity of chemical composition amongst the alloy steels is of very great importance.

The three instances given above will probably indicate the value of the chemical analysis, quite apart from its direct influence upon the mechanical properties of the steel, although these are of the most vital importance to the engineer. These reasons do not detract in any way from the importance of the statement made at the beginning of this chapter, that chemical composition *per se* is of no great importance to the engineer, and that he should regard it as a means to an end. When, however, the desired physical properties have been fixed, the engineer will be very well advised to pay careful attention to the chemical composition of his parts.

**Mass Effect in Hardening.**—The effect of mass in hardening has been generally described in Chapter III, p. 70, and the effect of it upon the mechanical properties of plain carbon steels has been dealt with at length in Chapter V. One of the reasons for the employment of alloy steels is the avoidance, in as large a measure as possible, of the defects associated with mass effect. The extent to which the alloy steels avoid the troubles connected with mass effect, varies according to the intensity of the hardening which takes place when they are cooled in air. It was shown in Chapter III that the mass effect in hardening was a reflection of the fact that, in large-sized pieces, the rate of cooling of the interior of the piece was not sufficiently high to prevent some decomposition of the solid solution in that part. It was also shown that one of the effects of the addition of alloys to steel was to increase the stability of the solid solution, and, therefore, to lower the critical rate at which the solution must be cooled, if decomposition is to be avoided. Obviously, the steel in which decomposition proceeds to the least extent, or, in other words, the steel in which the critical rate of

cooling required to produce hardening is the lowest, is a steel which hardens throughout to its maximum possible tensile strength when it is cooled in air. (This means that the steel when cooled in air has approximately the same tensile strength as it would have when cooled in oil or in water.) In such a steel the critical rate of cooling is very low, and the mass of a part must be exceptionally great if the steel in its interior is to cool at a rate slower than that required to harden it more or less completely. It is evident, therefore, that what was said above is correct, namely, that the avoidance of the mass effect in hardening is a function of the ease with which a steel hardens when cooled in air.

In the detailed description, given above, of steels suitable for various strengths, several types of steel were described. It was stated definitely that the plain nickel steel and the plain chromium steel did not harden when cooled in air from the ordinary temperature used for heat treatment. Practically all the other steels do harden in air, to a greater or less degree. The degree to which the different steels harden can be seen from the figures given in Table 43, showing the mechanical properties of the steels for the different classes given above, after cooling in air from the usual hardening temperature.

TABLE 43.  
THE MECHANICAL PROPERTIES OF DIFFERENT ALLOY STEELS  
AFTER COOLING IN AIR.

(Diameter of specimens at time of heat treatment— $1\frac{1}{8}$  inches.)

Class.	Kind of Steel.	Cooled from ° C.	Max. Stress, tons per sq. in.	Elongation, %.	Impact, ft.-lb.
1	Nickel chromium	820	114	11	14
2	Nickel chromium	830	78	14	7

The results given in Table 43 have all been obtained upon 1½-inch round bars. The air-hardening properties of the steel are more severely tested if larger bars are allowed to cool, and the test made upon a specimen cut from the core of the bar. Such results are shown in Table 44.

TABLE 44.

SHOWING THE TENSILE STRENGTH OF THE CORES OF 3-INCH BARS OF DIFFERENT NICKEL CHROMIUM STEELS COOLED IN AIR.

Class of Steel.	Heat Treatment.	Max. Stress, tons per sq. in.	Elongation, %.	Impact, ft.-lb.
1 (high nickel)	Air hardened 820° C.	114	11	13
2 (high nickel)	Air hardened 830° C.	76	13	7
3 (high nickel)	Air hardened 830° C.	65	16	6
4 (low nickel)	Air hardened 850° C.	56	14	7

The results given in Table 44 differentiate the steels more markedly than do those given in Table 43, and it is evident that all those steels which contain more than 3 per cent. of nickel, with an appreciable quantity of chromium (and with not less than 0·3 per cent. of carbon), are more or less air hardening, whilst those containing only half this proportion of nickel cannot be considered to have such air-hardening properties as will be of real use in combating the effect of mass. The above discussion might be interpreted as meaning that parts of large mass should always be made of air-hardening steel, which to a limited extent is true. Parts of large mass should certainly be made of steels which harden in air to an appreciable extent, but it would be ridiculous to suggest that all large parts should be made from steel which air hardens completely, i.e., the steel suggested for Class 1 above. Such steel should be used only if the part must be hardened in air for some adequate reason, and there is no reason to suppose that the majority of parts of large mass will be hardened in air. The majority of such parts will be hardened in oil, and it will be found that

those steels which harden to some extent in air, though not to their maximum possible tensile strength, will harden much more intensely in oil. (But this does not refer to steels which harden to their maximum tensile strength in air, and which, therefore, show no mass effect at all when hardened in that way.) The semi-air hardening properties of the steel described for Class 2, become useful when the steel is hardened in oil, since, with this treatment, the rate of cooling is increased and the centre cools at a rate higher than its critical rate of hardening, and thereby avoids mass effect. In other words, the rate of cooling of the interior of large parts, when cooled in air, is lower than the critical rate of hardening of this steel, whereas the rate of cooling, when cooled in oil, is higher than the critical rate. This point is made clear by the figures given in Table 45, which illustrate the mechanical properties of some of the nickel chromium steels enumerated above, after they have been hardened in different ways in pieces of different size. It will be seen that those steels which, when cooled in air, harden to some extent even in large parts, show an almost complete absence of the mass effect in hardening, when cooled in oil.

TABLE 45.

SHOWING THE MASS EFFECT OF HARDENING IN DIFFERENT STEELS HARDENED IN DIFFERENT WAYS.

Steel.	Heat Treatment.	Diameter of Bar, inches.	Max. Stress, tons per sq. in.	Impact, ft.-lb.
{ Class 1	Air hardened 820° C.	3	114	13
{ Class 1	Air hardened 820° C.	1½	114	14
{ Class 2	Air hardened 830° C.	3	76	7
{ Class 2	Air hardened 830° C.	1½	78	7
{ Class 2	Oil hardened 830° C.	3	111	11
{ Class 2	Oil hardened 830° C.	1½	112	12

The important point, therefore, about the selection of a steel which shall avoid the ill effects of mass, is that the steel chosen, although it may not harden completely when cooled in air, should yet harden to some appreciable extent after this treatment. This fact was necessarily taken into account by the author, when making the choice of steels, given above, for the different ranges of strength called for.

### **Choice of the Best Class of Steel for any Particular Part.**

—A matter of very great importance to the engineer is the wise choice of the steel which is to give any particular strength. If the engineer has decided that in any particular part he requires a certain strength, he can see, by reference to the various tables of mechanical properties given in the earlier part of this chapter, that a very considerable number of steels can be used in order to produce this strength. (It is assumed at the moment that the author's choice of steels as given above is neglected.) Some of the steels will give the required strength after cooling in air without tempering, others require to be hardened in oil without tempering, whilst it is possible to choose steels which would require to be hardened in water and not tempered. Other steels, on the other hand, could be hardened in any of the three different ways mentioned above, and tempered at various temperatures in order to produce the desired result. To illustrate the point, let it be imagined that the engineer requires a strength of, say, 75 tons per square inch in his part. In Table 46 are set out the mechanical properties of a number of steels, each of them possessing a tensile strength of not less than 75 tons per square inch, though each steel is different, and has been heat treated in a different way.

If the tensile strength is the only thing to be considered in the allocation of steel to a part, the choice of steels is very wide. In what way, therefore, is the engineer to exercise a wise selection? An examination of the figures in Table 46 makes it clear at once that the different steels, although agreeing very nearly in their ultimate



strength, vary very widely indeed in their toughness values. The engineer desires a steel which will give him the best possible toughness along with the requisite strength for his part, and he is, therefore, justified and well advised to use the steel which gives the highest toughness value. This statement may be put in other ways. First, of two steels which are available for any particular job, both of them giving the required tensile strength, the one which should be used, other things being equal, is the steel which

TABLE 46.

SHOWING THE DIFFERENT HEAT TREATMENTS REQUIRED BY VARIOUS STEELS TO PRODUCE A MAXIMUM STRESS OF 75 TONS PER SQUARE INCH.

(Diameter of specimens at time of heat treatment— $1\frac{1}{8}$  inches.)

Steel.	Heat Treatment.	Max. Stress, tons per sq. in.	Elongation, %.	Impact, ft.-lb.
A	Air hardened 820° C., tempered 500° C.	76	16	32
B	Air hardened 820° C., not tempered	73	14	7
C	Oil hardened 830° C., tempered 450° C.	76	16	23
D	Oil hardened 850° C., tempered 400° C.	77	17	14
E	Water hardened 850° C., tempered 500° C.	74	16	10
F	Water hardened 860° C., tempered 400° C.	75	14	11
G	Water hardened 870° C., not tempered	77	10	3
H	Oil hardened 860° C., not tempered	81	13	18

gives the best impact value when treated to the strength required. Secondly, if two steels are available for any particular purpose, the one which should be chosen is the one which requires to be tempered at the higher temperature. An examination of the heat treatment figures given in Table 46 will make the correctness of this second statement quite apparent. (In this connection see also p. 81 upon the benefits resulting from the hardening and tempering of engineering steels.)

**Surface Defects of Alloy Steels.**—The manufacture of

the alloy steels presents greater difficulties than are met with in the manufacture of the plain carbon steels. The ordinary difficulties attendant upon the production of sound ingots are the same, whether the steel is an alloy steel or a plain carbon steel, but additional troubles arise with the alloy steels, principally in connection with the behaviour of the surface of the ingot. These difficulties do not always arise in the manufacture of the ingot, but may occur during the subsequent heatings and coolings of the ingot in the course of the processes of forging and drop forging. As a general rule, it may be taken that the difficulties in connection with the surface are more pronounced in the hard than in the soft alloy steels, and they become most pronounced in the steels which harden intensively when cooled in air. It is very difficult to ensure that the surface of an ingot shall be absolutely smooth and free from slight folds or kinks. Such irregularities in the surface may be comparatively harmless in the soft plain carbon steels, or in the soft alloy steels which do not harden in the air, but in a steel which does harden in air they tend to the production of cracks. This is probably due to the effects of contraction, which produce considerable stresses in the surface of the steel. The production of these stresses has been indicated in Chapter II, and in consequence of the hardening of the alloy steel, the ductility of the metal is reduced considerably. Consequently, the ability of the steel to distort, and to accommodate the various stresses produced in and round the cracks, is distinctly less in the hard alloy steels than in the plain carbon steels. For this and other similar reasons it is not unusual for tiny cracks to be formed in the surface of the ingots. From the reasons given for the production of these cracks, it is quite evident that the harder the steel after cooling in air, the more prone it will be to develop surface flaws.

Since the cracking of the surface of the steel is a direct result of the changes which occur during heating and cooling, it is evident that the flaws may be produced

during the processes of drop stamping or forging, just as they may develop during the cooling of an ingot, since in either of these processes the steel is necessarily heated and cooled through the critical temperatures. Sudden changes of section in a drop forging may assist towards such a concentration of stress in the skin of the steel as will produce a flaw, and the persistence of the original surface flaws of the ingot, during the processes of forging and drop forging, tends towards the same result. With those steels which, after cooling in air, have a tensile strength of 75 tons per square inch or more (and reference to the detailed descriptions of the different steels given earlier in this chapter will make it apparent that a very considerable proportion of the nickel chromium steels do attain a strength equal to this), there is a serious tendency towards the development of surface cracks in the ingots and forgings, and with such steel it is essential that steps be taken to eradicate the sources of trouble at the start. The steelmaker attacks the defects by various methods. First of all, he endeavours to prevent the steel from cooling through the critical ranges oftener than is absolutely necessary. By transferring the steel hot from the ingot mould to soaking pits, and by carrying out the early forging operations upon the steel before it has cooled down to atmospheric temperature, it is often possible to avoid the commencement of serious flaws. For various reasons, the complete forging down of the steel cannot be carried out without allowing the steel to cool to ordinary temperatures. When once it has gone cold it is usually desirable to remove the external surface of the billet or bloom, particularly if the steel air hardens powerfully. During the forging operation the surface flaws may have been enlarged slightly, and they have probably been altered in shape. By rough turning, the defective skin of the billet can be taken away, and the sources of the surface cracks removed to a great extent. Some steel works do not remove the defective surface by rough turning, but attempt to get rid of the flaws by chipping or grinding.

This process is sometimes effective, but is by no means always so, as the chipping or grinding frequently burrs the metal over the flaw, making it appear as though the flaw had been removed, whereas it has only been partially removed and hidden. Such a hidden flaw is, of course, quite as dangerous as one which has been left intact.

Unless the surface flaws have been entirely removed from the alloy steels, it is fairly certain that they will develop further during the operations of drop forging. Even supposing that they do not cause the drop forging to crack in an obvious manner during forging, they are bound to give rise to serious trouble during heat treatment. The small radius at the bottom of the cracks will produce such a concentration of stress, during the operation of hardening, as will almost inevitably burst the forging (see Appendix A). It is essential, therefore, that the drop forger shall arrange, whenever possible, for the rough machining of drop forgings, prior to heat treatment, when they are made from a steel which air hardens to any high degree. In Fig. 70 is shown a billet containing a fairly obvious defect, which arose from the unsound surface of an ingot. In Fig. 71 is shown a forging made from steel containing such flaws. In Fig. 72 is shown a forging which was made from apparently sound steel, but in which small flaws were present, which were not removed before heat treatment, with the result that the forging developed a serious crack during heat treatment.

**The Fatigue Range of Alloy Steels.**—A knowledge of the fatigue range possessed by the different alloy steels is of considerable importance to the engineer. Comparatively few determinations of the fatigue range of such steels have been made, but in Tables 47 to 49 and Fig. 73, the results of tests upon several steels are quoted. The steels tested include 100-ton air-hardening nickel chromium steel (corresponding to Class 1 above), an oil-hardened and tempered nickel chromium steel (corresponding to Class 3 above), an oil-hardened and tempered nickel chromium steel (corresponding to Class 4 above),

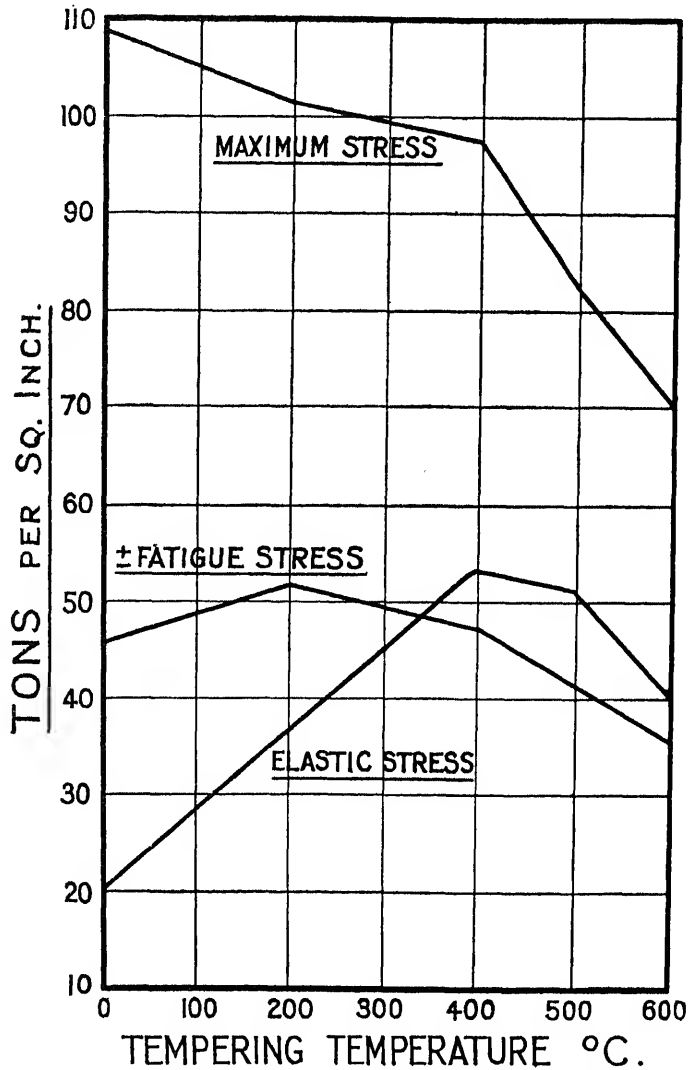

FIG. 73.—CURVES SHOWING THE FATIGUE RANGE AND OTHER MECHANICAL PROPERTIES OF AIR HARDENING NICKEL

and an oil-hardened and tempered chromium vanadium steel (corresponding to Class 4 above).<sup>1</sup>

TABLE 47.

SHOWING THE MECHANICAL PROPERTIES IN TENSION AND FATIGUE OF A STEEL CONTAINING

CARBON	..	..	..	..	0.30	per cent.
SILICON	..	..	..	..	0.22	„
MANGANESE	..	..	..	..	0.56	„
NICKEL	..	..	..	..	4.30	„
CHROMIUM	..	..	..	..	1.44	„

AFTER HARDENING IN AIR FROM 800° C. AND TEMPERING AT VARIOUS TEMPERATURES.

Tempering Temperature °C.	Elastic Limit, tons per sq. in.	Yield-point, tons per sq. in.	Max. Stress, tons per sq. in.	Elongation, %.	Reduction of Area, %.	Fatigue Range, tons per sq. in., Wöhler.
—	20.0	78.8	109.1	10.8	36.6	±45.5
200	36.2	77.5	101.2	12.5	41.6	±51.5
400	53.3	80.5	97.9	10.0	36.2	±47.5
500	51.7	71.3	82.4	15.0	46.4	±41.5
600	40.9	63.3	70.1	17.5	55.1	±35.5

The fatigue test results show quite clearly, as was suggested in Chapter IV, that there is no relationship at all between the fatigue range, when the steel is stressed to an equal amount “plus” and “minus,” and any other property of the material, excepting the maximum stress. The ratio between the fatigue range and the maximum stress is very fairly constant, and varies from about .95 to 1.03. In other words, the plus or minus fatigue stress is approximately equal to half the maximum stress of each steel tested.

**Stainless Steel.**—In addition to the various normal alloy steels already described, there are a number of other

<sup>1</sup> *Report of Materials Section, Air Ministry.* H.M. Stationery Office, 1921.

steels, which contain varying proportions of alloying elements, but do not fall within the limits of composition

TABLE 48.

SHOWING THE MECHANICAL PROPERTIES IN TENSION AND FATIGUE OF A STEEL CONTAINING

CARBON	..	..	..	..	0.32	per cent.
MANGANESE	..	..	..	..	0.46	„
NICKEL	..	..	..	..	3.48	„
CHROMIUM	..	..	..	..	0.78	„

AFTER HARDENING AND TEMPERING.

(Diameter of specimens at time of heat treatment— $1\frac{1}{8}$  inches.)

Elastic Limit, tons per sq. in.	Yield-point, tons per sq. in.	Max. Stress, tons per sq. in.	Elongation, %.	Reduction of Area, %.	Fatigue Range, tons per sq. in.	
					Haigh.	Wöhler.
55.0	59.5	65.7	21.1	60.4	±33.0	—
—	49.1	57.5	25.8	66.8	—	±27.9

TABLE 49.

SHOWING THE MECHANICAL PROPERTIES IN TENSION AND FATIGUE OF A STEEL CONTAINING

CARBON	..	..	..	..	0.44	per cent.
MANGANESE	..	..	..	..	0.49	„
CHROMIUM	..	..	..	..	0.95	„
VANADIUM	..	..	..	..	0.20	„

AFTER HARDENING AND TEMPERING.

(Diameter of specimens at time of heat treatment— $1\frac{1}{8}$  inches.)

Elastic Limit, tons per sq. in.	Yield-point, tons per sq. in.	Max. Stress, tons per sq. in.	Elongation, %.	Reduction of Area, %.	Fatigue Range, tons per sq. in., Wöhler.
44.8	54.7	62.9	20.0	54.6	±32.8

previously dealt with. These steels are generally used for special purposes and require some notice. The first

a steel of recent development, has gripped the imagination of many people, and is likely to be put to many and various uses, other than those which have become apparent up to the present. Stainless steel contains a high proportion of chromium, from 12 to 15 per cent. In the proportion of the alloying element present in the steel, only high-speed steel can compare with stainless steel. The amount of carbon in it is fairly low. For cutlery purposes the steel contains usually about 0.30 per cent., though for other purposes, in which the stainless property is of supreme importance, and the cutting edge of only subsidiary interest, the proportion of carbon is rather lower, e.g., as low as 0.15 or 0.20 per cent.

Contrary to the belief of many people, the stainless property of the steel is not a virtue which is only skin deep, i.e., the stainlessness does not depend upon some doping process performed upon the surface of the steel, but, owing to the large proportion of chromium in the composition, continues throughout the mass. The only rôle which the skin plays is, that for perfect resistance to corrosion, the surface of the steel must be smooth, polished, and free from parts which have been strained. If the skin of the steel be scratched or torn at any point, then there is a likelihood of the commencement of rusting at this point, because the steel at these points has been cold worked to some extent. As stated before, to prevent any corrosion, the surface must be smooth, though this smoothness is not necessarily the polish produced upon electro-plate or such-like surfaces—a reasonably good result being obtained from a surface which has been planished. It is quite possible to find a surface which has been machined with fine tools, so that there has been practically no tearing or distortion of the metal, presenting a very fair resistance to corrosion.

As it is probable that stainless steel will be utilised for many other purposes than cutlery, it is desirable to give some indication of its mechanical properties after appro-



that should be mentioned is stainless steel, which, although a steel of recent development, has gripped the imagination of many people, and is likely to be put to many and various uses, other than those which have become apparent up to the present. Stainless steel contains a high proportion of chromium, from 12 to 15 per cent. In the proportion of the alloying element present in the steel, only high-speed steel can compare with stainless steel. The amount of carbon in it is fairly low. For cutlery purposes the steel contains usually about 0·30 per cent., though for other purposes, in which the stainless property is of supreme importance, and the cutting edge of only subsidiary interest, the proportion of carbon is rather lower, e.g., as low as 0·15 or 0·20 per cent.

Contrary to the belief of many people, the stainless property of the steel is not a virtue which is only skin deep, i.e., the stainlessness does not depend upon some doping process performed upon the surface of the steel, but, owing to the large proportion of chromium in the composition, continues throughout the mass. The only rôle which the skin plays is, that for perfect resistance to corrosion, the surface of the steel must be smooth, polished, and free from parts which have been strained. If the skin of the steel be scratched or torn at any point, then there is a likelihood of the commencement of rusting at this point, because the steel at these points has been cold worked to some extent. As stated before, to prevent any corrosion, the surface must be smooth, though this smoothness is not necessarily the polish produced upon electro-plate or such-like surfaces—a reasonably good result being obtained from a surface which has been planished. It is quite possible to find a surface which has been machined with fine tools, so that there has been practically no tearing or distortion of the metal, presenting a very fair resistance to corrosion.

As it is probable that stainless steel will be utilised for many other purposes than cutlery, it is desirable to give some indication of its mechanical properties after appro-

essential to any engineer who proposes to use stainless steel in his designs. Stainless steel is an air-hardening steel, and can be hardened in this manner to practically the same degree of hardness as by quenching in oil. If it is to be hardened in air, the steel is usually cooled from a temperature near to 950° C., while if it is to be hardened in oil a temperature of 900° C. to 920° C. will generally be found quite satisfactory. After hardening by either of these methods, a maximum stress of approximately 100 tons per square inch can readily be obtained. Stainless steel, like all the alloy steels, can then be tempered in the customary way, and by this means a reduction of strength to approximately 40 tons per square inch can be achieved. The changes in mechanical properties produced by heat treatment are shown by the figures in Table 50 and the curves given in Fig. 74.

TABLE 50.

MECHANICAL PROPERTIES OF STAINLESS STEEL, AFTER HARDENING AND TEMPERING, CONTAINING

CARBON .. .. . 0.40 per cent.

CHROMIUM .. .. . 12.2 „

(Diameter of specimens at time of heat treatment—1 inch.)

Heat Treatment.	Yield-point, tons per sq. in.	Max. Stress, tons per sq. in.	Elonga- tion, %.	Reduction of Area, %.	Impact, ft.-lb.
Air hardened 900° C., tempered —	—	98.8	Nil	Nil	5
Air hardened 900° C., tempered 300° C.	99.6	104.0	2.5	8.7	5
Air hardened 900° C., tempered 400° C.	98.8	103.2	7.5	11.8	6
Air hardened 900° C., tempered 500° C.	92.6	93.2	6.0	21.4	4
Air hardened 900° C., tempered 600° C.	55.0	62.0	15.0	41.9	13
Air hardened 900° C., tempered 650° C.	50.2	56.8	18.0	45.9	13
Air hardened 900° C., tempered 700° C.	46.4	53.6	20.0	49.7	25
Air hardened 900° C., tempered 750° C.	42.6	51.4	28.0	52.2	30

Evidently, the range of strength available with stainless steel is quite considerable, and, in fact, is equal, if not

superior, to that obtainable with any other steel. The other alloy steels which, when hardened in air, can be relied upon to give a strength approaching to 100 tons, cannot be tempered down to such a low figure as 40 tons (see the test results given for the nickel chromium steels

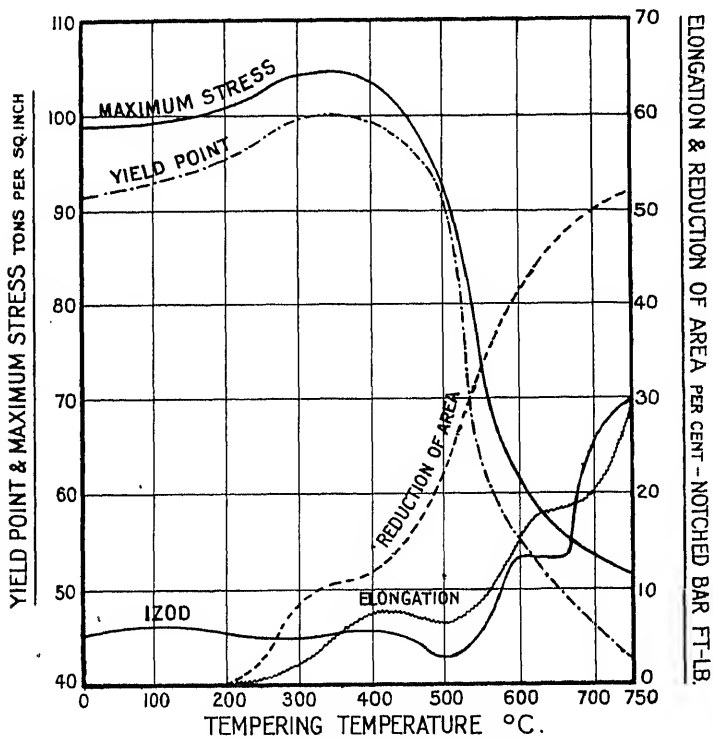

FIG. 74.—THE MECHANICAL PROPERTIES OF STAINLESS STEEL AFTER TEMPERING AT VARIOUS TEMPERATURES.

on pp. 180 and 189). An examination of the values given in Fig. 74 with those recorded in Figs. 63 to 66 indicate clearly that there is a further considerable difference between the properties of the two classes of steels represented therein, and this difference is evident in the alterations produced in the mechanical properties of the

steels when tempered at temperatures higher than  $600^{\circ}\text{C}$ . The nickel chromium steels suffer a notable loss of strength if the tempering temperature is increased by, say,  $25^{\circ}\text{C}$ . within this range. On the other hand, the stainless steels are only affected slightly by an increase of tempering temperature of  $25^{\circ}\text{C}$ . The strength of a specimen of stainless steel, tempered at  $650^{\circ}\text{C}$ ., is not a great deal higher than that of one tempered at  $750^{\circ}\text{C}$ . This fact is of value in the treatment of the steel, as it means that an error of a few degrees in the tempering temperature will not result in any serious difference between the strength desired and the strength obtained.

A study of the test results given in Table 50 makes another point clear, namely, that the critical hardening temperature of the steel is very high. Plain carbon steel can be hardened, theoretically, by quenching from a temperature of  $740^{\circ}\text{C}$ . Nickel steel may be hardened from  $700^{\circ}\text{C}$ ., nickel chromium steel from a temperature of  $750^{\circ}\text{C}$ ., but stainless steel must be heated to a temperature higher than  $830^{\circ}\text{C}$ . if it is to be hardened at all. This fact is naturally of importance in the heat treatment of the steel, but it is of equal, if not greater, importance in the forging and rolling. It is possible to forge low carbon steel down to a temperature of  $730^{\circ}\text{C}$ . without "cold working" it. Stainless steel, on the other hand, must not be forged at a temperature lower than  $830^{\circ}\text{C}$ ., or else it will be cold worked and possibly damaged considerably. It will also create havoc among the tools used in the treatment.

**Ball-Bearing Steel.**—Another alloy steel, and one which is used very widely, is the special steel used for "direct hardening" ball bearings. It has been the practice for a long time to case-harden ball bearings, but the alloy steel, which becomes hard throughout the part is replacing the other steels to a considerable extent. The particular alloy steel employed is, like stainless steel, a steel containing chromium. The steel has a fairly high proportion of carbon, of the order of 0.8 to 1.0 per cent., and this is

reinforced by the addition of 1.2 to 1.6 per cent. of chromium. Steel of such a composition will harden in oil (or water) very efficiently, and give a Brinell hardness number of at least 555, which represents material of a strength of about 110 tons per square inch. The steel may be tempered at low temperatures, e.g., up to 200° C., to improve the toughness and remove some, at any rate, of the strains left in the steel as a result of the quenching. This treatment does not appreciably affect the hardness.

## CHAPTER VII

### CASE-HARDENING STEELS

CASE-hardening steels enter very largely into modern engineering work, and particularly the lighter forms of machinery. The steels are used because they permit the production of a hard surface, capable of withstanding a good deal of frictional abrasion, upon material which can be machined readily. It is frequently claimed, also, that, by case hardening a piece of steel, an article is obtained which is as hard as tool steel, but as tough as wrought iron. The accuracy of this claim will be referred to again later. It is a fact, however, that the case-hardening steels are soft, and, therefore, can be machined readily and speedily, and that, by carburising these steels, they can be given a surface which can be made as hard as tool steel. The superior hardness of the outside is obtained by increasing the proportion of carbon in it through the process of carburising. The change of carbon content produced in the part can be demonstrated readily by two methods. The first is to remove the steel from the part layer by layer, and to analyse each successive layer for carbon. The carbon content of each layer can then be plotted against the depth of the layer, in the way that has been done in Fig. 75. The second method is to make a micro-section of the part, and to observe the change of structure which is found on passing inwards from the skin of the part. The result of such an examination is shown in Fig. 76, which makes it clear that on the outside of the part there is more than 0.9 per cent. of carbon (as indi-

cated by the existence of the free carbide of iron), whilst, in the interior, there is only about 0.1 per cent. of carbon (as shown by the large proportion of excess iron). The carburised portion of the article is termed the "case," and the unaltered interior, the "core."

It is evident that any case-hardened article consists

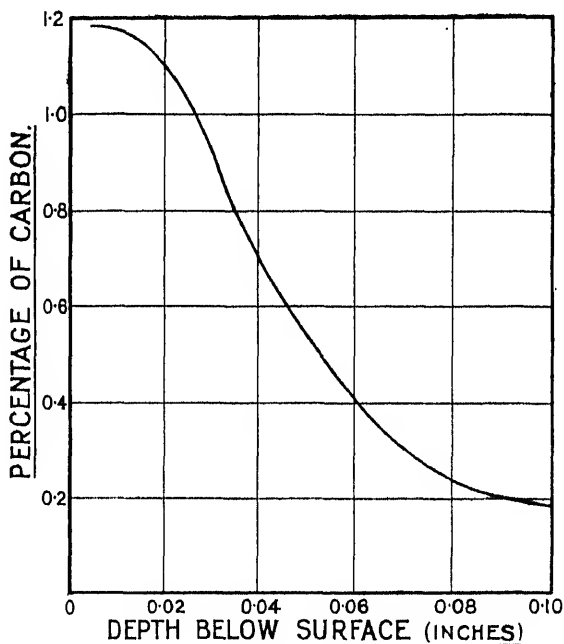

FIG. 75.—CURVE SHOWING THE PERCENTAGE OF CARBON AT DIFFERENT DEPTHS BELOW THE SURFACE OF A CASE-HARDENED BAR.

of two very distinct and definite portions—the core and the case, and that, since the compositions of the two parts are so different, their mechanical and other properties will likewise differ markedly. The two portions are so distinct in their natures that, if they could be separated, they would be heat treated in decidedly different ways. Since, however, they are not separable, the treatment

which is to be given to the case-hardened article must, if possible, be such as will suit both, or, at any rate, do no harm to either. If such an arrangement of treatment is impossible, then it becomes necessary to subordinate the interests of one portion to those of the other, and to treat the article in the interests of the more important portion. Undoubtedly, the more important portion of a case-hardened article is the case. This is obvious, since case-hardening steels are only used for the "easy" production of an article with a hard surface, and this hard surface is the case. In all points, therefore, concerning the treatment, etc., of case-hardening steels, in which the interests of the case and the core differ, those of the case must receive priority of consideration. Since, however, it is practically useless to produce a good and properly hardened case upon a core which is totally unsatisfactory, the choice of the most suitable steel for the core is of great importance. The core must follow (to a considerable extent) the case in its heat treatment, and must, therefore, be made of such a steel as is not harmed or spoiled by the treatment accorded to the case.

It may be advantageous, at this stage, to consider very briefly what are the real functions performed by both case and core in a case-hardened article. The crude definition, given above, of the case-hardening process would indicate that the true function of the case is to be hard, and that of the core to be tough. But surely it is desirable that the case shall be tough in its measure, and there appears to be no reason why the core should not sometimes be comparatively hard. Also it must be remembered, that the core must be tough under the conditions of its production, i. e., after quenching from a well-defined temperature (used to harden the case), and without tempering. Another function which the core must fulfil is that of being capable of easy and rapid machining in the condition in which it is delivered to the machine shops. In other words, it must be soft (in the machining sense) in its normal condition. The properties, therefore,



respectively, are as follows :

*Case* : (a) To be thoroughly hard under the conditions of service, the term hardness to be interpreted in terms of that service.

(b) To be as tough as is possible in such material as the case will be shown to consist of.

*Core* : (a) To be adequately soft when in the normal condition.

(b) To be adequately tough after being quenched in such a way as is necessary to harden the case.

(c) To be (by using various steels) of different strengths, according to the nature of the article and its design.

The condition (c) for the core is necessary for certain parts ; in particular, for those parts in which the case is not produced over the whole surface of the part, e.g., a cam shaft. In such a part, the "core," in the portions bearing no case, has to play the ordinary rôles of a structural non-case-hardening steel, and varying strengths may be necessary for this purpose. The other reasons for the use of cores of varying strength will emerge later in this chapter. At this stage it is only necessary to state the ways in which the varying strengths can be achieved.

Case-hardening steels are all of them low in carbon. This fact is dictated by the need for their being tough after the usual heat treatment which they receive. It is not possible, therefore, to obtain the gradations of strength in the cores of different articles by varying the carbon content, as is done in the ordinary structural steels. The additional strength of the core must be obtained in other ways, and the means employed must be such as do not impair the toughness of the steel to an unnecessary degree, when it is hardened during the hardening of the case. It is customary to gain the additional strength by the introduction of alloying elements—nickel or nickel and chromium together. By the use of

suitable proportions of these elements, it is possible to raise the strength of the core of a case-hardened article from approximately 35 tons per square inch to 85 or 90 tons. This practice has led to the general adoption of various semi-standardised case-hardening alloy steels, of which the following may be regarded as the ones most widely used :—

(1) Plain carbon steel, containing not more than 0·20 per cent. of carbon.

(2) 2 per cent. nickel case-hardening steel, containing not more than 0·15 per cent. carbon.

(3) 3 per cent. nickel case-hardening steel, containing the same carbon content as (2).

(4) 5 per cent. nickel case-hardening steel, containing the same carbon content as (2).

(5) Nickel chromium case-hardening steel, containing about 3·5 per cent. of nickel, about 0·5 per cent. of chromium, and not more than 0·15 per cent. of carbon.

(6) Special nickel chromium case-hardening steel, containing about 4 per cent. of nickel, about 1·25 per cent. of chromium, and not more than 0·15 per cent. of carbon.

The chemical composition found in actual specimens of these various steels (and, therefore, indicating more or less the kinds of steel usually met with in practice), are shown in Table 51.

The range of tensile strength, and the concomitant variations in toughness, of these steels after heat treating in the usual way, is shown by the figures in Table 52. In this table the values quoted for the maximum stress are those which can be relied upon for each steel. They are by no means necessarily the highest possible figures, but are those which the steels, as met with commercially, ought to give without difficulty, and are, therefore, those which the engineer can employ for the purpose of the calculations necessary for his design.

TABLE 51.

## CHEMICAL COMPOSITION OF TYPICAL CASE-HARDENING STEELS.

No.	Type.	Carbon, %.	Silicon, %.	Manga- nese, %.	Sulphur, %.	Phos- phorus, %.	Nickel, %.	Chro- mium, %.
1	Plain carbon	0.17	0.05	0.85	0.032	0.023	—	—
2	2% Ni	0.16	0.15	0.58	0.035	0.030	2.0	—
3	3% Ni	0.19	0.32	0.45	0.028	0.021	3.00	0.23
4	5% Ni	0.16	0.11	0.43	0.044	0.033	4.65	0.29
5	3% Ni 0.5% Cr	0.20	0.28	0.39	0.033	0.022	3.15	0.58
6	4% Ni 1.25% Cr	0.16	0.27	0.35	0.028	0.031	3.85	1.25
7	6% Ni	0.11	0.18	0.20	0.031	0.033	5.76	0.10
8	Plain carbon	0.21	0.15	0.96	0.060	0.038	—	—
9	6% Ni	0.16	0.30	0.33	0.021	0.020	5.85	—
10	3% Ni	0.14	0.09	0.57	0.026	0.028	3.42	0.11
11	Plain carbon	0.13	0.08	0.46	0.042	0.035	—	—

TABLE 52.

## TYPICAL MECHANICAL PROPERTIES OF THE USUAL CASE-HARDENING STEELS.

Steel.	Max. Stress, tons per sq. in.	Elongation, %.	Reduction of Area, %.	Notched Bar Value, ft.-lb.
1	32	20	55	40
2	36	20	55	50
3	45	15	45	40
4	50	13	40	30
5	55	13	40	30
6	65	12	35	20

Naturally, it is not possible to use a case-hardening steel for its core properties alone, and it is quite essential that all the steels employed shall be capable of receiving a good case. The influence of the alloying elements upon the properties of the case is, in general, to decrease the hardness slightly. No steel gives quite such a file-hard case as the plain carbon steel, and the nickel steels

give a softer case as the percentage of nickel in the steel increases. The two nickel chromium steels produce a case which is not quite so soft as the nickel steels, but, at the same time, is not quite so hard as the plain carbon steels. Steel No. 6, given above, gives a case which most nearly approaches in hardness that produced on steel No. 1. (When speaking of the hardness of a case-hardened article, it is not possible to quote determinations made in a really comparative and accurate manner, since there is no really satisfactory test for hardness. The most usual method of testing the hardness of a case-hardened part is by attempting to scratch it with a new file. This, of course, is only a very rough-and-ready test of the properties of the case. A new file will not scratch the case produced on steels 1 and 6, though it is not unusual for such a file to scratch the case on steels 3 and 4. It is very doubtful whether the file test is any real indication of the truly useful properties of the case of a case-hardened article.)

#### CASE-HARDENING PROCESS.

The actual process of case hardening consists of four definite operations :

- (1) The production of the case by carburising or cementing.
- (2) The refining of the core.
- (3) The refining of the case.
- (4) The hardening of the case, and, incidentally, of the core.

Each of these processes is essential to the successful production of a good case-hardened article, and each one presents certain features which are peculiar to itself. They therefore call for separate discussion.

**Carburising or Cementing.** — This operation aims at the production of the unhardened case. The actual method employed to form a case on the skin of the case-hardened object, is to increase the proportion of carbon

in the steel. The carbon is introduced by a chemical reaction between the steel and some gas which contains carbon. The gas is usually produced from a case-hardening mixture which is solid, and in which the articles are packed (all together in a box), the whole being heated to the carburising temperature. The use of the solid mixture, as the apparent carburising agent, has led to the belief that solid carbon in the mixture is the direct cause of the

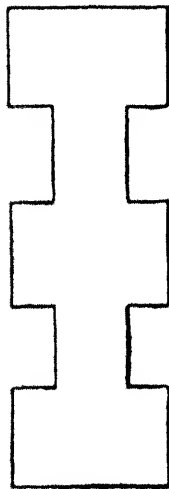

A

FIG. 77. — TEST SPECIMEN TO SHOW CARBURISATION BY GAS.

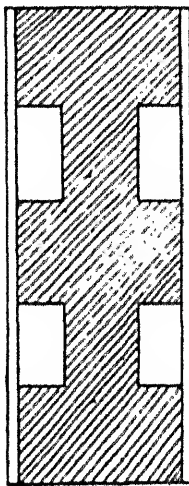

B

FIG. 78. — TEST SPECIMEN FITTED IN CONTAINING TUBE.

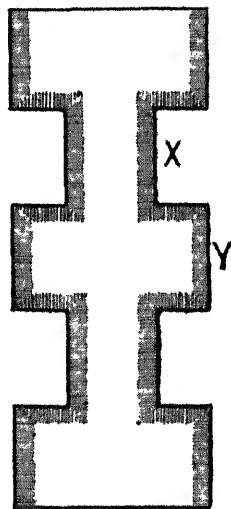

FIG. 79. — DISTRIBUTION OF CASE ON TEST SPECIMEN AFTER CARBURISING.

absorption of carbon by the steel. This is not correct. The carburising of steel occurs as a result of interaction of iron with gas, as can be seen by the following experiment. From a bar of case-hardening steel machine a specimen with grooves to the shape shown in Fig. 77. Insert this specimen, as a driving fit, in a tube of case-hardening steel, and hermetically seal the ends, so that the combined part is as shown in Fig. 78. Heat the com-

bined piece in the carburising mixture for a suitable time, remove from the mixture when cold, and cut a section through the grooved specimen. Etch this specimen to indicate the distribution of the case. It will be found that the case is distributed as shown in Fig. 79. The steel at the back of the grooves is carburised to just the same depth as is that on the raised parts, despite the fact that the latter was in metallic contact with the enclosing tube, whilst the former could only be carburised by gas which has penetrated through the tube.

Since the carburising of the steel is carried out by the gases containing carbon, which are provided by the case-hardening compound, it is desirable to use, as carburising agent, a mixture which will liberate the carbonaceous gases in their largest quantities at the effective carburising temperatures. The most important gas for the operation of carburising is carbon monoxide, and the usual temperature used for carburising is round about  $900^{\circ}\text{C}$ . The problem is, therefore, to prepare such a mixture as will liberate carbon monoxide in the largest quantities, at a temperature of about  $900^{\circ}\text{C}$ . Most of the carburising mixtures employed have ground charcoal as a basis, and to this various other ingredients are added. The most usual substances to add to the carbonaceous constituents are the carbonates of the alkalis or the alkaline earths, and the two most frequently employed are barium carbonate and sodium carbonate, of which the former is more generally used. One very well-known mixture consists of 60 parts of wood charcoal and 40 parts of barium carbonate, whilst another mixture, widely used, consists of wood charcoal impregnated with about 10 to 12 per cent. of sodium carbonate. Many case-hardening mixtures contain a proportion of water, whilst others contain oil. These substances are usually added to avoid the troubles arising from dust during the mixing process, but they really constitute impurities. They play no active part in the carburising of the steel, and they absorb heat, either in their evaporation or in their charring.

It is desirable, therefore, to avoid mixtures which contain more than the smallest proportion of water or oil. In Table 53 the compositions of a number of case-hardening mixtures are set out, showing the tremendous variation existing in the composition of these materials. It is difficult to see what advantage can be obtained from the presence of many of the substances which are found in them.

TABLE 53.  
COMPOSITION OF VARIOUS CARBURISING MIXTURES.

Mixture.	Constituents.	Proportions.
(1)	Wood charcoal Barium carbonate	60 parts by weight. 40 parts by weight.
(2)	Wood charcoal Common salt	7 to 9 parts by weight. 3 to 1 parts by weight.
(3)	Wood charcoal Potassium ferrocyanide Ammonium chloride Common salt Water	6 bushels. 11 lb. 30 lb. 20 lb. 30 quarts.
(4)	Wood charcoal Common salt Sawdust	1 part by weight. 1½ parts by weight. 1½ parts by weight.
(5)	Charred leather Potassium ferrocyanide Sawdust	10 parts by weight. 2 parts by weight. 10 parts by weight.
(6)	Horn and hair Vegetable fibre Soda ash Crushed firebrick Water	20 per cent. by weight. 50 per cent. by weight. 11 per cent. by weight. 5 per cent. by weight. 14 per cent. by weight.
(7)	Soot Plaster Potassium ferrocyanide	20 per cent. by weight. 40 per cent. by weight. 40 per cent. by weight.
(8)	Vegetable husks Soda ash Sand Water	70 per cent. by weight. 13 per cent. by weight. 3 per cent. by weight. 14 per cent. by weight.

Tests can be made, and have been made, of the actual volumes of gas liberated by the various mixtures at different temperatures. Similar tests can be made to determine the composition of the gases liberated at the different temperatures. The information given by such tests provides a satisfactory method of determining the real value of a case-hardening mixture. Both of these operations are intricate and tedious. A more satisfactory method is an empirical one, in which the mixture is tested by its effect upon a standard piece of steel. A standardized piece of this standard steel is carburised for a fixed time at a fixed temperature. After cooling down, the sample is quenched from the proper temperature, and a cross-sectional surface polished and etched with dilute nitric acid. The section shows the depth of the case which has been produced. The depth of the case enables the quality of the case-hardening mixture to be evaluated. To determine the durability of the case-hardening mixture, a second standard sample may be treated, under the same conditions as before, with some of the mixture which has already been used.

*Carburising Temperature.* Having chosen the carburising mixture and the case-hardening steel which are to be used, the next thing to do is to select the temperature at which carburising is to be carried out. So far as is known (and information on the subject is not very extensive or deep) the carburising operation is controlled by two things, first, the upper critical temperature of the steel, and, secondly, the viscosity of the solid solution of carbide of iron in iron formed in the steel at a temperature higher than the critical. It is usually believed that it is not possible to carburise a steel, unless it has been heated to a temperature higher than the upper critical point. Whether this is absolutely true or not, it is quite certain that it is useless to try to carburise a steel effectively and practically at a lower temperature than the critical point. The second controlling factor, i.e., the viscosity of the solid solution in the steel, is fairly easy to appreciate.



It will help, however, in the appreciation of the actual process, if the absorption of carbon by the steel is more carefully examined. When the steel is heated in the carburising gas, a reaction takes place between the iron of the steel and the gas, whereby the carbon of the latter unites with the former to produce a carbide of iron. This compound, of course, is produced on the outermost skin of the steel, and, when formed, dissolves in the remainder of the iron which is present, thereby forming a solid solution of iron carbide in iron (see Chapter III, p. 49). When once it has dissolved, the carbide will tend to diffuse within the steel, in the same way as any dissolved substance tends to diffuse throughout its solvent, and, probably, it will do this in accordance with the ordinary laws of solution. The diffusion means that the particles of the dissolved substance travel through the solvent as quickly as they can, and ultimately they necessarily travel inwards towards the middle of the part. The speed with which they travel will be a measure of the rate of carburisation of the steel, and the speed will be controlled (to some extent, at any rate) by the viscosity of the solid solution. The more viscous is the solid solution, the less rapid will be the diffusion. The viscosity of the solid solution (in the iron) is approximately inversely proportional to its temperature, so that the higher the temperature to which the steel is heated the less viscous will it become, and hence the more rapidly will the carbide travel. The influence of the viscosity is probably greater than that of the critical temperature upon the process of carburisation, and the choice of carburising temperature is more affected by the viscosity of the steel than by its composition. (The upper critical temperature of a steel is a function of its composition. In the carbon steels the relationship is shown by the line ABCD in Fig. 27. The variations of the critical temperature with composition in the nickel steels have been indicated in Chapter III, the general effect of the presence of nickel being to lower the upper critical temperature.) In con-

viscosity, it is usual to disregard the temperature of the critical point, and to choose the carburising temperatures of the case-hardening steels more or less arbitrarily. The actual temperatures which are generally employed are shown in Table 54.

TABLE 54.

SATISFACTORY CARBURISING TEMPERATURES OF CASE-HARDENING STEELS.

Steel.	Carburising Temperature ° C.
Plain carbon .. .. .	925-950
2 % nickel .. .. .	900-920
3 % nickel .. .. .	880-900
5 % nickel .. .. .	880-900
6 % nickel .. .. .	880-900
Nickel chromium .. .. .	880-900

*Speed of Carburisation.* Having fixed the temperature at which the steel is heated, and also the mixture to be employed, the rate at which the articles become carburised is thereby determined. The rate of absorption of carbon is very largely fixed by the temperature. This follows from what has been said above, regarding the influence of the temperature upon the viscosity of the solid solution produced in the steel. It is also certain that the formation of the compound of iron and carbon is more rapid at high, than at low temperatures. On the other hand, it is possible that the case-hardening compound will not give such good results if the temperature is raised too much. Each of the various mixtures has its optimum working temperature, and, at this temperature, it yields carbon monoxide in the largest proportions. If the temperature of carburisation is 900° C. to 950° C.—as it usually is—then the rate at which the case is produced depends upon the compound employed, and, with the best mixtures, it is usually about .01 inch per hour. This,

of course, refers to the time after the part and the mixture have been heated up to the carburising temperature. Even then, this rate of penetration is very rarely maintained for the whole period of carburisation, so that, with the average mixture, the time required for the formation of a case of the normal depth (i.e., 0.03 to 0.035 inches) is about four to five hours. In actual practice, this time is frequently exceeded a little (see Fig. 80).

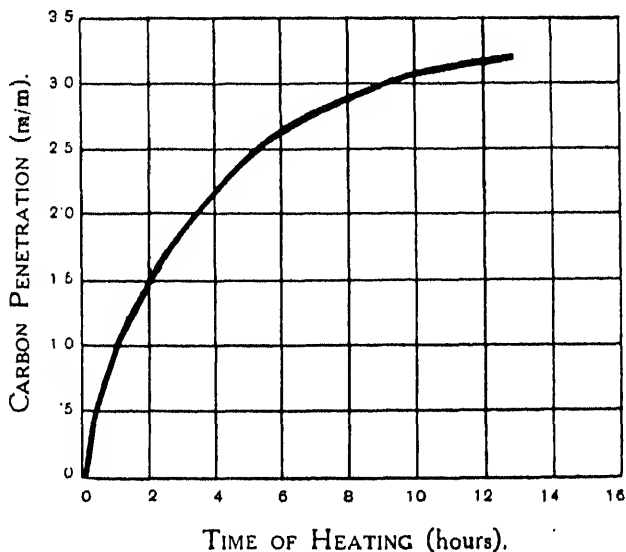

FIG. 80.—CURVE SHOWING THE RATE OF ABSORPTION OF CARBON BY A STEEL DURING CARBURISATION WITH "HARDENITE."

The time required to produce the same thickness of case is affected also by the nature of the steel which is being treated. The plain carbon steels are, in general, the more rapid absorbers of carbon, possibly due to the lower viscosity of the solid solution formed in them.

The nickel steels do not absorb carbon from case-hardening mixtures at quite the same rate as do the plain carbon steels. If, for instance, a 3 per cent. nickel steel and a

plain carbon steel be heated for the same length of time, at the same temperature, with the same carburising mixture, it will probably be found that there is a difference of about 15 per cent. between the carbon content of the case on the nickel steel and that on the plain carbon steel. That is to say, if the maximum carbon in the case produced on the plain carbon steel be 1.0 per cent., that produced in the case of the nickel steel will be 0.85 per cent., and so forth. This means, as a rule, that it is desirable to carburise the nickel steels for a somewhat longer time than the plain carbon steels. Chromium has no appreciable effect upon the rate of absorption of carbon, by the steel, during the carburising operation. A nickel chromium case-hardening steel, however, will require a somewhat longer time than a carbon steel. Table 55 shows the approximate time required to absorb the same quantity of carbon by the six typical steels given above.

TABLE 55.

COMPARATIVE TIME AT THE SAME TEMPERATURE REQUIRED BY DIFFERENT STEELS TO ABSORB THE SAME AMOUNT OF CARBON.

Steel.	Comparative Time.
Plain carbon .. .. (1) <sup>1</sup>	100
2 % nickel .. .. (2)	115
3 % nickel .. .. (3)	120
5 % nickel .. .. (4)	135
3.5 % nickel, 0.5 % chromium .. (5)	130
4 % nickel, 1.25 % chromium .. (6)	135

It is of considerable importance that a proper depth of case shall be obtained upon case-hardened articles. Unless the case is sufficiently deep, the process of case hardening is practically useless and unnecessary, since no

<sup>1</sup> The figures in brackets refer to the compositions of the steels given

adequately hard surface can be obtained. The failure of a very large number of articles can be traced to the presence of an insufficient depth of case. For most purposes, a suitable depth is about  $\frac{1}{30}$  inch. When deciding upon the depth of case, various points should be taken into account. In the first place, it is not desirable, either from the view of economy or efficiency, to make the operation of carburising more lengthy than is necessary. Secondly, it is very undesirable to have a case which is very high in carbon, and which, therefore, contains quantities of free carbide on the outer surface. Thirdly, as stated above, there must be a sufficiently deep case to provide a thoroughly hard surface after treatment. It is possible, by extending the period of carburisation very considerably, and by allowing the operation to proceed slowly at a low temperature, to produce a deep case without having a very large excess of carbon on the outside. In these circumstances the case has a more uniform carbon content than is otherwise obtained. For practical purposes, however, it may be considered that it is not possible to form a case of any great depth without producing an excess of carbon on the surface, which shows itself as free carbide after cooling. (The dangers due to the presence of free carbide are mentioned in connection with flaking at the end of this chapter.) The depth of case, therefore, is to some extent controlled by the maximum carbon allowable in the outer layers. For ordinary working, about 1.10 per cent. of carbon in the outermost layer is sufficient, and this will be obtained in a case of about  $\frac{1}{30}$  inch deep in the ordinary way, if the carburising be carried out correctly with a good case-hardening mixture.

It is quite possible to produce an excess of carbide on the skin of a part on which an ordinary depth of case has been formed. This will happen if the rate of formation of the carbide is especially high. It will readily be appreciated that the formation of the case on the article is the result of first, the production of the carbide, and

secondly, its diffusion into the mass of the article. If the carbide is produced faster than it can diffuse, then there is bound to be an accumulation of carbide on the surface of the part. The rapid formation of the carbide appears to result most frequently from the use of too high a carburising temperature. It is possible (though not very practical) to overcome the excessive formation of carbide on the surface of a part, by heating the articles for a lengthy period, so that the carbon has an opportunity to diffuse more evenly through the mass of the steel. This may be done by cooling the articles very, very slowly, so that in reality they are annealed during the cooling process. It also may be achieved by removing the articles from the carburising mixture, and re-heating them to a temperature of about 900° C. in a separate container. In either process, the intention is to permit the carbide to diffuse as well as it can, under circumstances which do not provide the opportunity of much more carbide being formed. As a practical proposition, neither of these alternatives is very appealing, and it seems to be very much better to prevent the formation of the excess of carbide altogether. This can be done by limiting both the time and the temperature of carburisation.

The presence of free carbide in quantities in the case of a case-hardened article results in the existence of too brittle a case. By its very nature, it is scarcely possible to produce a case which is really tough in the ordinary sense of the term. It is, therefore, of the utmost importance that nothing should be done to decrease what toughness the case actually does possess. The presence of much free carbide has a definitely embrittling effect, as it provides opportunities, which would otherwise be lacking, both for the start and for the growth of cracks. These may be produced either during hardening or during the working of the article. The comparative lack of cohesion between the free carbide and the rest of the steel makes the junctions of the two constituents very prone to separation, and a crack started on the surface of a part will very

easily spread along the free carbide, as is seen plainly in Fig. 81.

**Refining and Hardening.**—When the carburisation is complete, the articles are allowed to cool down to the ordinary atmospheric temperature, usually in the carburising box. When they are cold they are soft (in the great majority of parts), both in case and core, and they have all the defects of large grain size which are usually associated with steel which has been exposed at temperatures above its critical range for any length of time. Evidently, two things remain to be done to the articles. In the first place, they must be made hard—at any rate in the case—and, in the second place, they must be refined, or purified from the ill effects of the exposure at high temperatures. The refining must be effected in both the case and the core. Take the case first, as this is the more important portion of the article. The usual way of getting rid of the evil effects of overheating is by normalising, and, therefore, the obvious thing to do with the case is to normalise it. In order to normalise a steel, it must be heated to a temperature at least as high as the upper critical point. The critical temperature of a steel depends upon its composition. The exact composition of the case of a case-hardened article is not accurately known, but it is usually assumed to be not very far from 1.0 per cent. of carbon. A reference to Fig. 27 will show that the normalising temperature for such a steel is about 770° C. In order, therefore, to refine the case of the case-hardened article, it is only necessary to heat it to a temperature of about 770° C., and allow it to cool. If this is done, then the structure of the case will be refined completely, and the coarse structure resulting from the exposure to the high temperature replaced by a fine one—namely, the one that is desired in the finished article.

The temperature of normalising is also, by definition, the theoretically correct hardening temperature. In order, therefore, to harden the case, it would have to be heated to 770° C. and then quenched. As there is no need

to perform two heatings of the article, and also, since the method of cooling in the refining operation has no effect upon the success of the refining, it is convenient to effect the refining of the case by heating it to its normalising temperature, and to harden it by quenching it from the same temperature. As the operation of hardening is more obvious in its results, it is common to overlook and to ignore the refining operation, which is an essential part of the process of heating up to the hardening temperature.

The temperature of  $770^{\circ}\text{C}$ ., mentioned above as being suitable for the treatment of the case, is quite satisfactory for such cases as are usually produced upon articles made in plain carbon steel. If the steel contains alloying elements, then the temperature for refining and hardening the case may profitably be varied somewhat. As the critical temperatures of the nickel steels are lower than those of the carbon steels, the nickel steels can be refined and hardened at lower temperatures. In actual practice, the variation of temperature introduced is not very great, and, unless the proportion of nickel is 5 or 6 per cent., a hardening temperature of about  $760^{\circ}\text{C}$ . is used. The very high nickel steels can be hardened from  $720^{\circ}$  or even  $700^{\circ}\text{C}$ . quite satisfactorily. The usual hardening temperatures for those case-hardening steels mentioned earlier as being typical, are given in Table 58.

One of the ill effects of the presence of an excess of carbide in the case, can be seen from a consideration of the alterations that should be introduced into the operations of hardening and refining the case in order to meet it. To refine completely a steel containing, say, 1.45 per cent. of carbon (which is not too much to imagine in the case of an article that has been over-carburised), it is necessary to heat it up to a temperature of about  $930^{\circ}\text{C}$ . If the refining and the hardening of the case are to be performed at the same time, the articles ought to be quenched from this temperature. To do so would be almost impossible in practice, because of the excessive



quenching strains which would be set up in the article, and the very great likelihood of cracks being formed during hardening. These two practical considerations make a fairly low quenching temperature, i.e., about 760° C. or 770° C., essential for the high carbon steels, with the result that they are not fully and properly refined by heating to the hardening temperature, if they contain too great a proportion of carbon.

When the case-hardening steel contains a high percentage of nickel, e.g., over 5 per cent., or contains a high percentage of nickel with chromium, e.g., steel No. 6 given above, it is possible to produce, by the ordinary carburising action, a case which has the property of hardening in the air. A 6 per cent. nickel steel would require about 1.0 per cent. of carbon in the case, if it were to become air hardening, but the nickel chromium steel, such as No. 6 given above, will probably become air hardening in the case when the percentage of carbon has risen only to about 0.35 per cent. The case upon the nickel steel will, therefore, be air hardening in the outer layers, whilst the case on the nickel chromium steel will be air hardening for almost the whole of its thickness. This very useful property of the case on such steels can be utilised in various ways, and particularly to avoid the distortion which so frequently occurs during the refining and hardening of case-hardening steels. This aspect of the process will be referred to again below. It is important to note, if the air-hardening properties of the case produced upon these steels are being utilised, that the strength of the core will be very much lower after air cooling than if the steels were quenched in water or in oil. Taking the 5 per cent. nickel steel as an example, the core, after cooling in air, will probably have a strength of about 36 tons per square inch, whilst, after quenching in water, it will have a maximum stress of about 60 tons per square inch. This fact has to be set off against the advantages obtained by cooling the part in air.

A considerable difference of opinion exists as to whether

or not the case-hardening steels should always be quenched in water, or whether, in some cases, they should be quenched in oil. This controversy refers only to the process of hardening. As was stated above, in the refining operation it is not necessary to quench at all, since the refining operation owes its effects to the temperature to which the steel has been heated, and not, in any way, to the method employed for cooling it. As regards the hardening of the case, there is a common belief that, whatever steel is being used, the case is hardened more efficiently if quenched in water than if quenched in oil. This belief has grown up in consequence of the fact that it expresses the truth in regard to moderately large-sized bars of plain carbon steels. It does not necessarily, however, express the truth in regard to the alloy steels. The previous paragraph has indicated that it is possible to harden the case produced upon some alloy steels by simply cooling the parts in air. If this be so, it is evident that the case on these steels will be efficiently hardened in oil. If the hardness of the case, therefore, is the only thing which is receiving attention, there is no reason why a great many of the other steels should not be quenched in oil instead of in water. In Table 56, a satisfactory treatment is shown for the different alloy steels which will produce a really hard case. This treatment is only intended to refer to the hardening of the case, but it must always be borne in mind that whatever treatment is given to the case is reflected in the properties of the core. It is not possible to treat the core and the case of case-hardening steels separately. It is pointed out above that when the case on the article is allowed to harden by cooling in air, the core will be in a comparatively soft condition. It must similarly be pointed out here that if the case is hardened by quenching in oil, the core of the article will not be hardened so efficiently as if the steel were quenched in water. This means that the core of the steel will be in a distinctly softer condition when quenched in oil than when quenched in water. In

upon the case and the core of the case-hardening steels is set out. This table also shows, adequately, the effect upon the mechanical properties of case-hardening steels of adding alloying elements to them.

TABLE 56.

SHOWING HARDENING TEMPERATURE AND SUITABLE MEDIUM FOR QUENCHING DIFFERENT CASE-HARDENING STEELS.

Steel.	Hardening Temperature ° C.	Quenching Medium.
Plain carbon .. .. .	760	Water
3 % nickel .. .. .	760	Water
5 % nickel .. .. .	730-750	Oil
6 % nickel .. .. .	720-740	Oil
Nickel chromium .. .. .	750	Oil

TABLE 57.

SHOWING THE HARDNESS OF THE CASE AND THE STRENGTH OF THE CORE OF CASE-HARDENING STEELS COOLED IN DIFFERENT WAYS.

Steel.	Method of Cooling.	Condition of Case.	Max. Strength (approximate) of Core.
Plain carbon ..	Water	Hard	35
Plain carbon ..	Air	Soft	22
3 % nickel .. ..	Water	Hard	55
3 % nickel .. ..	Air	Soft	32
5 % nickel .. ..	Oil	Hard	60
5 % nickel .. ..	Air	Half hard	38
6 % nickel .. ..	Oil	Hard	56
6 % nickel .. ..	Air	Hard	38
Nickel chromium ..	Oil	Hard	75
Nickel chromium ..	Air	Hard	45

The refining of the core is quite as necessary as the refining of the case, and is effected by the same means, namely, a normalising operation (see Figs. 82 and 83). It is necessary, in order to refine properly, to heat the article to a temperature a little higher than the upper critical point of the core. This temperature should be well known, because the composition of the core (which fixes its normalising temperature) is the same as that of the original steel. For the plain carbon steels the normalising temperature is shown clearly by the line ABCD in Fig. 27, and, as the majority of the plain carbon case-hardening steels contain no more than about 0.2 per cent. of carbon, it is evident from Fig. 27 that all these steels can be refined at a temperature of 880° to 900° C. If the steels are not plain carbon, but contain alloys, then, in general, the upper critical temperature is lower than that of the plain carbon steels, and the articles need not be heated quite to such a high temperature. The refining temperature of the cores, which are suitable for the commoner types of case-hardening steels, are shown in Table 58.

TABLE 58.

REFINING AND HARDENING TEMPERATURES FOR DIFFERENT STEELS.

Steel.	Refining Temperature ° C.	Hardening Temperature ° C.
Plain carbon .. .. . (1) <sup>1</sup>	900-920	760
2 % nickel .. .. . (2)	880-900	760
3 % nickel .. .. . (3)	860-880	760
5 % nickel .. .. . (4)	800-840	730-750
3.5 % nickel, 0.5 % chromium .. (5)	810-830	760
4 % nickel, 1.25 % chromium .. (6)	790-820	745

After heating to the refining temperature, it is the common practice to cool the article rapidly—usually in

<sup>1</sup> The figures in brackets refer to the compositions of the steels given in Table 51.

water. Much of the benefit of the refining operation is frequently attributed to the method of cooling. This is really quite incorrect, as the benefit of refining comes from heating the article to a temperature slightly higher than the upper critical point. When the steel has been raised to this temperature the refining has been accomplished, and no variation of the method of cooling can affect the efficiency of the refining operation. The core of a case-hardened article is just as well refined when the part is cooled in air as when it is cooled in water or in oil. Moreover, the danger of distortion is notably decreased by cooling in air. It is, however, not to be assumed that there is no benefit whatever to be obtained from the practice of cooling in water or in oil from the refining temperature of the core. The rapid cooling does not affect the actual refining, but it does influence the mechanical properties of the hardened part—a little. The core of a part which has been cooled rapidly from the refining temperature, and then hardened at the temperature required to harden the case, is perhaps two or three tons per square inch stronger than a core which has been cooled in air from the refining temperature and subsequently hardened. The advantage is not very great, but it does exist. When the strength of the core is of no great importance, the articles can well be cooled in air from the refining temperature, in order to avoid any unnecessary distortion, but, if the highest core strength is aimed at, then the articles may profitably be quenched in water or in oil.

An examination of the temperatures in Table 58 shows that the refining temperatures of the cores, particularly in the plain carbon steel, are distinctly higher than those used to refine the case. If the case, after being refined, was heated to the refining temperature of the core (particularly if the case contained the normal proportion of carbon), the effect of refining would be partly undone. On the other hand, no ill effects would result from heating the refined core to the refining temperature of the case. For

this reason then, if for no other, it is evident that the refining of the core must be effected before that of the case is attempted. The correct order, therefore, of performing the operations is :

1. Refine the core.
2. Refine the case.
3. Harden the case, and incidentally harden the core.

The mechanical properties of the core after they have been treated fully, i.e., refined and then hardened along with the case, have already been indicated in Table 52.

#### MASS EFFECT IN HARDENING.

It has been shown that all steels are prone to exhibit, in certain degrees, the influence of the size of the specimen at the time of heat treatment. This is due to the fact that the interior of a part cools at a slower rate than the exterior, and that every solid solution must be cooled at not less than a certain specific rate, if it is to be retained in the solid solution form when it has cooled down to normal temperatures. The solid solutions formed in case-hardened steels—due probably to their low carbon content—are rather less stable than those formed in most other steels, and hence, during the cooling of the steels, are more likely to decompose. This means that the case-hardening steels are more prone to suffer from the effect of mass than the majority of steels. This is of great importance to the designer who desires a certain definite strength in the core of the articles that he is manufacturing. The test results usually quoted are those obtained by the quenching of bars  $1\frac{1}{2}$  inches in diameter. If the articles have a ruling diameter greater than this, the strength obtained in the core, by quenching, will be less than that found in the  $1\frac{1}{2}$ -inch bars. In parts such as large gears or pinions or crankshafts, the decrease in strength due to the greater mass may be very notable. The general effect of the variation in size of the article at the time of heat treatment can be seen plainly from the examples

quoted in Table 59. In addition to the loss of strength in the larger parts, the gain in strength of the parts less than  $1\frac{1}{2}$  inches is noteworthy. The higher strength may at times be useful, but it is important to realise that the gain in strength is accompanied by a loss in toughness, the impact values falling off distinctly. This is sometimes rather serious, and leads to the production of case-hardened articles which have strong but brittle cores.

TABLE 59.

## MASS EFFECT IN HARDENING OF CASE-HARDENING STEELS.

Steel.	Size of Bar. Diameter in inches.	Yield-point, tons per sq. in.	Max. Stress, tons per sq. in.	Impact Value, ft.-lb.
Plain carbon (8) <sup>1</sup>	$2\frac{1}{2}$	22.9	40.1	90
	$1\frac{5}{8}$	23.8	41.5	102
	$1\frac{1}{2}$	24.9	44.3	85
	$1\frac{1}{8}$	26.6	49.8	82
	$\frac{3}{4}$	27.3	54.3	74
6 % nickel (9)	$2\frac{1}{2}$	50.3	64.6	67
	$1\frac{5}{8}$	53.4	83.5	58
	$1\frac{1}{2}$	64.8	91.2	50
	$\frac{3}{4}$	65.3	91.8	41
3 % nickel (10)	$1\frac{1}{2}$	37.4	47.8	49
	$1\frac{1}{4}$	45.8	54.9	42
	1	43.9	59.3	38
	0.564	67.8	80.9	28

Such a result may be sufficiently serious in its effects to warrant a remedy, if such can be found. The toughness of the core might be increased by tempering, but such a process would have a fatal effect upon the hardness of the case. The only permissible remedies are those which do not affect the case. The easiest way of reducing the hardness, and, therefore, of increasing the toughness of the core, is by quenching the articles in a less drastic

<sup>1</sup> The figures in brackets refer to the compositions of the steels given in Table 51.

manner. If the articles are made in plain carbon steel, and are too brittle when quenched in cold water, a better result can be obtained by using oil or hot water as the quenching medium. This change reduces the speed of cooling of the core, and, therefore, diminishes the hardening effect, thereby improving the toughness of the core of the article.

The effect of mass is a matter of considerable importance in connection with the use of case-hardening steels, and must be taken into account carefully by the designer who is using them. Most quotations for the strength of case-hardening steels are made upon the results of tests carried out on bars either 1 or  $1\frac{1}{8}$  inches in diameter. It is sometimes assumed, however, by the unwary, that the same tensile strength will be obtained in the core of a part which has a ruling diameter of 3 inches made in the same steel. A reference to Table 59 will show at once that such a strength is not obtainable in the steel.

The alloy steels containing a comparatively large percentage of alloy, e.g., steels 5 and 6 in Table 51, are not quite so susceptible to the mass effect in hardening as are the remainder of the steels. Even these steels, however, suffer a distinct loss of strength when the mass of the part at the time of quenching is increased. For large work, however, it is probably safer to use them, than to use the steels containing a lower percentage of alloying element.

#### THE MECHANICAL TESTING OF CASE-HARDENING STEELS.

The most satisfactory method in which to test case-hardening steels is a subject of some considerable importance. It is necessary to test both the core and the case of such steels, or of the articles made from them. At the commencement of this chapter it was shown that the core and the case had definite functions to fulfil, and that, in order to perform these functions in the best manner, they must have certain more or less definite mechanical properties. These mechanical properties of the core were, a



strength greater than a pre-determined minimum, and a toughness also greater than a specified minimum, but also as great as possible. Of the properties which the case should possess, the primary one was hardness. The nature of this hardness has been considered in connection with the conditions under which it is displayed. The case must also be tough in its degree. The attainment of this toughness has also been dealt with. All these four properties of the case-hardened part should be tested, if complete knowledge regarding case-hardening steel is to be attained. First of all consider the case, and primarily its hardness. Unfortunately, this is an exceedingly difficult property to test. As stated on p. 105, the perfect test for hardness has not yet been evolved, and the methods employed are somewhat crude.

It is not possible to test the hardness of the case of a case-hardened part by means of the Brinell test. This test would crush the case, and probably crack it, and, therefore, render the part useless. Under any circumstances, the readings would be of little value, since the depth of the impression made by the ball of the Brinell machine would probably be of something of the same order as the thickness of the case. This means that the core resistance would be called into play. The results would, therefore, be entirely misleading. The limitations of the scleroscope were illustrated on p. 106. Almost the only method, therefore, which is capable of general application, is that of testing the hardness of the surface by attempting to scratch it with an instrument of known hardness, usually a file. This would be satisfactory if all files had the same hardness. Unfortunately, all files are not equally hard, and also, the hardness of any particular file is not the same when quite new, and after it has been in use for some little time. A file which has been in fairly constant use for a little time is usually quite hopeless for the purpose of testing the hardness of a case-hardened part. The practice of testing with a file is likely, however, to hold its place in consequence of its convenience, and

also in consequence of the general satisfaction v gives to the user. A method which is quite as goc not better than, the use of a file, is to use, as the soi medium, a round bar of tool steel which has been cor hardened. The bar should be of comparatively; diameter, and should be cut perpendicular to the the bar. The resulting cross-section is then gr that the edges are absolutely sharp. The perip this cross-section can be used most effectively as : of testing the hardness of the case of case-hardene In consequence of the considerable circumference section, it is possible to utilise the tool for a muc number of tests than is possible with a file. It also, to renew the business part of the tool by g down the bar a little further. Such a proceeding is sible with a file.

To determine the toughness of the case of a case-h part is, at present, beyond the possibilities of me testing. The formation of tough and brittle ce already been shown, and the general nature of th once between them indicated. When the case h produced, the best guide as to its mechanical pr other than hardness, is probably provided by its structure. As a consequence of accumulated exp the connection between structure and toughness k reasonably established, and the microscope is c more use than any mechanical method so far de

To test the properties of the core of case-h steels, a sample which has not been carburised c be employed, or else a sample which has been ca and from which the case has been removed by ma In order to determine whether or not the core p the mechanical properties which were described e tial, it is only necessary to carry out a tensile o test to estimate whether the steel is strong en support the case, and to carry out an impact test to judge of the toughness of the steel. The ter will be made in the ordinary way, upon a test pie

has been subjected to the refining and hardening heat treatments, which would be given to a properly case-hardened article. It is not necessary to heat the specimen to the carburising temperature before refining and hardening, or to retain it at this high temperature for the carburising period, although this is very often done. The omission of this treatment has no effect at all upon the physical properties of the test piece representing the core. It is essential that the refining and hardening be carried out upon a bar of standard size. The mass effect in hardening is particularly apparent in the treatment of case-hardening steels, and it is, therefore, quite essential that precautions should be taken to avoid the variations in mechanical properties arising from this cause. The most usual size of specimen to heat treat is a bar  $1\frac{1}{8}$  inches in diameter. The test piece is machined from this specimen. The impact test piece should be machined from the same or a similar specimen of steel which has been heat treated in the full size, i.e., in the  $1\frac{1}{8}$ -inch round bar, if this be adopted as the standard. It is impossible to take any notice of impact tests made upon test samples cut from specimens which, when heat treated, are of different size from that of the specimens from which the tensile test pieces are cut, although this is not uncommonly done. The impact test piece is, of course, not carburised.

In actual practice, it is customary to make the tests, for the hardness of the case, upon the articles which are being manufactured. This is easy, since it is desirable to check a considerable proportion of the manufactured articles by direct observation, and the file test does not harm a properly hardened case. This large number of tests is often necessary, since it is not uncommon to find a considerable variation in hardness amongst the different articles which have been carburised in one and the same box. The tests for the core are preferably carried out

A great deal of attention has been paid in the past, and probably is still paid, to the appearance of the fracture of the core obtained by breaking a case-hardened specimen. A large number of users of case-hardening steels would be satisfied to use a steel if it presented, after heat treatment, a fine grey fibrous core. A steel which shows a core of this kind is often quite satisfactory, since such an appearance is frequently associated, in plain carbon steels, with the mechanical properties which are desired in the core of such an article. It is also often found to be true that, when a bright and platy fracture is shown by the core of a broken case-hardened specimen, the mechanical properties of this core are not equal to those of the core showing a fibrous fracture. It is also found, however, that unsatisfactory heat treatment is frequently the cause of the poor appearance of the fracture. It is of considerable importance to note, that it is very much better to judge the properties of the core of a case-hardened article by the actual mechanical properties revealed by the tensile and the impact tests, than by any visual examination of the fracture. It is possible to obtain fractures of widely varying appearances, by breaking the same piece of steel in different ways. If the sample which is being tested has been carburised, the appearance of the core may be quite different from that shown by a sample which has not been carburised. If a little notch has been put in the specimen, to help it to break, the appearance of the fractured core of such a piece may be distinctly different from that shown by breaking a sample which had no notch. The speed of making the fracture may also affect the appearance of the broken bar quite materially.

Apart from these points, the very fact of the existence of a fibrous appearance in the core may be an indication of a comparatively unsatisfactory case-hardening steel. The existence of fibre very frequently indicates the existence, in the steel, of an undesirably high proportion of slag or non-metallic inclusions. These inclusions have

been drawn out during the processes of forging and rolling, until they exist in the form of exceedingly attenuated threads, running parallel to the direction in which the steel has been elongated during forging or rolling (see Chapter II). These threads determine, to a considerable extent, the orientation of the crystals of the steel. The steel has formed itself round these threads, and, consequently, exists in a form somewhat similar to the insulation round an electric cable. A large number of these cables clasped tightly together, would give a fair representation of the condition of the steel. The central core of each cable is the slag, and the surrounding insulation is the steel. Obviously, such a steel has a fibrous structure, and will break with a fibrous fracture, but if this fibrous structure has been brought about by introducing a considerable proportion of slag into the steel, it is doubtful whether the end justifies the means. The troubles arising from the existence of slag will be dealt with below. All that is intended here is to draw strong attention to the desirability of trusting to definite mechanical tests, rather than to visual appearances which may be misleading.

#### THE PHYSICAL PROPERTIES OF CASE-HARDENING STEELS.

The method of testing the steel has now been elaborated. It is a matter of great importance to the engineer to decide in what way the results obtained from the tests shall be interpreted, and also what is the significance, from the standpoint of engine design, of the different properties of case-hardening steels which are revealed by these tests. A case of a certain minimum hardness is always required, and it is difficult to imagine any circumstances in which an engineer would deliberately go out of his way to produce a case which was not as hard as it possibly could be, consistent with the simultaneous existence of a maximum value of toughness. Without the hard case, the use of case-hardening steels is wasteful

which the engineer must make, is, in a considerable measure, determined by the properties of the core. It has been shown that different case-hardening steels can be selected, which will give a range of core strength, in  $1\frac{1}{8}$ -inch round bars, of from 30 to 90 tons per square inch. In each steel, the strength can be accompanied by a suitable toughness (as shown by the impact test), taking into account the fact that, as the maximum stress of steel increases, its impact value falls. The engineer has, therefore, to decide whether he will use a steel which has a high core strength, or a steel which has a low core strength. In general, it will be appreciated that the steels with a low core strength are cheaper than those with a high core strength, and, therefore, if the strong steels are to be used, the engineer must be convinced of the advantages which will accrue to him from the employment of such material.

At first sight, it would appear desirable that the core of the case-hardened part should be as strong as possible. It is worth while, however, to investigate this belief, and, if possible, determine whether it is sound, and also to discover the reasons for its being held. In the beginning, it is worth while to consider what really happens during the actual breaking of a case-hardened part. A perfectly simple section may be considered, which consists of a straight round bar, properly case hardened. This bar consists of two parts, the case and the core. Suppose that the part is broken, as a beam supported at the two ends and loaded in the middle. What will happen? Will the case break first, or will the core break first, or will the two parts break together? Whichever of these three possible courses is taken, will the strength of the core affect the load at which the part will break? When this experiment is tried, it is found that no apparent change occurs in the beam before the case breaks, and the first apparent failure of the part is the cracking of the case. When the case has broken, the behaviour of the core depends a good deal upon the circumstances. In some circumstances the core snaps off

quite short, and in others it deforms considerably before breaking, depending presumably upon the ductility and the toughness of the steel. A good deal also depends upon the way in which the test is carried out. It is found, however, in general, that the steels with a soft core deform considerably after the case has broken, while those with a hard core deform comparatively little. In Table 60 are set out the actual experimental results obtained in a series of beam tests carried out upon several case-hardening steels. The table also shows the comparative strengths in tension of the core. The case which was put upon each specimen was of the same depth (as nearly as is possible with such an operation). Tests of the penetration of the carbon were actually made upon special test samples treated along with the other test pieces.

TABLE 60.

BEAM TESTS ON CASE-HARDENED BARS, AND TENSION TESTS ON CORES OF CASE-HARDENED STEELS.

Steel.	Skin Stress (tension) at which the Case cracked in Beam Test, tons per sq. in.	Yield-point of Core, tons per sq. in. (Tensile Test).	Max. Stress of Core, tons per sq. in. (Tensile Test).
Plain carbon .. .. (1) <sup>1</sup>	64.4	24.1	40.3
3 % nickel .. .. (3)	92.8	40.0	66.2
3 % nickel chromium .. (5)	95.5	44.6	59.0
5 % nickel .. .. (4)	95.6	50.0	63.2

In each test the case broke first. The steels with a strong core required, however, a very much greater load to fracture the case than did the steels with the weaker core, the load required to break the specimens being, roughly, proportional to the tensile strengths of the cores. It might be imagined that the strength of the

<sup>1</sup> The figures in brackets refer to the compositions of the steels given in Table 51.

case would affect the results obtained. This might be true if the cases produced on the different steels differed markedly in strength. In actual fact they do not vary appreciably, and what difference does exist is very much less than, and in no way proportional to, the difference in the strengths of the corresponding cores. In general terms, the strengths of the cases may be regarded as the same in all the steels. It seems reasonable, therefore, to assume that if the core of the case-hardened part be strong, the strength of the part as a whole is high, since the core can resist the loads put upon the case, and can support the case better than if the core be weaker. This appears to indicate that the engineer is well advised to use a case-hardening steel with a high core strength.

The conclusions just reached must not be accepted, however, without considering the evidence obtained from the impact test. If an impact test piece is prepared from a steel which has been refined and hardened at the proper temperature, it may give, on breaking, an impact value of 60 ft.-lb. If an impact specimen of the same steel is carburised, refined, hardened, and then broken in the impact machine, it will probably be found that the impact value is only about 5 or 8 ft.-lb. This is a perfectly general experience, and is probably explained by a consideration of what takes place during the breaking of a non-carburised impact test piece. Whilst being broken during a test, an impact specimen deforms very considerably, before it is actually fractured. When a crack has been formed at the bottom of the notch, it has to be propagated across the test piece, and, during this propagation, a test piece which gives a high impact value bends very considerably, distorts and stretches the steel at the back of the test piece, and bulges out the steel on the sides of the specimen behind the notch. Undoubtedly, a consider-



take place to the same extent. The outer layer of the test piece is exceedingly rigid, and has a very low impact value indeed (probably only about 1 or 2 ft.-lb.). The core of the test piece is, therefore, contained in a rigid envelope. This rigid envelope requires only a small amount of energy to cause it to break, whether notched or not, and, since no distortion of the core of the test piece can take place, in consequence of the rigidity of the case, the impact value of the whole specimen is exceedingly small. Undoubtedly, the same kind of thing happens in actual practice. Many case-hardened parts break, and their fracture is almost invariably sudden (e.g., case-hardened gudgeon pins); that is to say, the whole part collapses when once the case has broken. (It should be noted that case-hardening steels are most often used in parts which are undergoing alternating stresses.) This evidence would suggest that it does not matter whether the core of the part is tough or whether it is brittle, i.e., in quite general terms also, whether it is weak or strong, as the toughness varies with the strength, *ceteris paribus*. It also makes it necessary to explain the difference between the results obtained on impact test pieces and those obtained in the beam tests described above, since in the impact test there is no distortion of the core, and in the beam test there is a distinct distortion of the softer cores. In all probability this is due to the method of breaking. In the beam tests the case cracks right round the specimen at more or less the same time, and, therefore, removes the constraining influence of the rigid envelope from a certain short length of the core. The complete circumferential fracture is due to the fact that the steel in the beam test is more or less uniformly stressed over the whole of the periphery of any cross-section. By the removal of the constraining effect of the rigid envelope in this way, the core is left free to distort as it will. Furthermore, in the beam test the load is applied slowly, and, when the case cracks, remains stationary until a further load is intentionally applied. No such removal of constraining

effect occurs in the test upon the case-hardened impact specimen, probably because the fracture starts from one side in consequence of a flaw or a groove, and, therefore, it is reasonable to expect some difference in the method of fracture of the steel under these two different sets of conditions. Probably, if the beam test was made very rapidly, there would be very much less distortion.

The results of the above two series of experiments might appear to contradict each other. It is not wise to argue that the beam represents conditions more usually met with in engineering practice than does the case-hardened, notched, impact test piece. Probably, in the majority of parts in actual practice, the conditions are a mean of the two, since it is difficult to say that the notch, which is characteristic of impact test pieces, is always, or even generally, absent from a case-hardened engine part. A small scratch, an unduly deep tool mark, or an unusually deep grinding mark in the engine part, will play the rôle of the notch in the impact test piece, and act in exactly the same way to hasten the fracture of the case-hardened part.

Under any circumstances, it appears that the crux of the matter is the failure of the case. If the case is taken by itself, i.e., if the core of the test piece is bored right away, and tested, it is found that there is comparatively little difference in the tensile strength of the case on a steel with a soft or a hard core. In reality, the case on plain carbon steel, and the case on a 6 per cent. nickel steel, after hardening on the top of the core, have almost exactly the same strength. It is not, therefore, the strength of the case in itself which decides the failure of the part, i.e., the fracture of the case, but it will be the stress which, when applied to the part as a whole, causes the fracture of the case, which will decide the fate of the case-hardened part.

The case and the core, when they are stretched, will presumably distort together, in accordance with the modulus of elasticity, since the value of  $E$  for the case

and the core is the same. Nothing will happen, therefore, until the elastic limit of the core or the case is reached, and slightly exceeded. At this point, the ordinary laws of stress distribution across the section fail to be applicable. Also, when the stress in either part has reached such a value that the yield-point of either the core or the case is reached, distortion of one or the other is likely to occur. It is reasonable to assume that the yield-point of the core will be reached a good deal sooner than that of the case, since the case may be safely assumed always to have a higher tensile strength than the core. When the part is stressed beyond the yield-point of the core, the case is still being stretched elastically, but the core is being distorted non-elastically. When this happens, the core may be assumed to flow, or to attempt to flow, and, therefore, to cease to support the case in the way that it did while being stretched elastically. After this support has been removed, the failure of the case may take place rapidly and easily, as it may easily become overloaded in some place at any time. It appears, then, that the failure of the case is really determined by the stress at which the core commences to flow in a plastic manner, that is, by the yield-point of the core. It is, therefore, reasonable to assume that the part which has a core with the highest yield-point will endure the greatest stress. With these conclusions as a basis, it seems reasonable that the engineer should use, where it is desirable in the design, a case-hardening steel with a high maximum strength, i.e., high yield-point, in the core.

The existence of a strong core in parts made of case-hardening steel is of considerable value under certain specific conditions. A considerable number of case-hardened parts are manufactured which are composite, since they are case hardened on only a portion of the surface. The remainder of the part is not case hardened, but, nevertheless, may be quite as fully stressed as any of the carburised portion. A typical instance is a cam shaft for an internal combustion engine. In this shaft the

cam faces need to be quite hard, because of the wear to which they are subjected. The greater part of the shaft is, however, not subjected to any surface or abrasive forces, having merely to submit to bending and torsional stresses. In an article of this kind, it is obviously of advantage that the shaft shall be made of steel which is as strong as possible. Hence the core of the case-hardening steel should be strong, quite irrespective of the properties which it may be required to possess when acting as the foundation for the case on the cam blocks.

The value of a strong core has also been shown in connection with heavily loaded disc cams. Several examples of these have been examined in which the core did not provide anything like sufficient support to the case. The case, in consequence, gradually sank into the core, which was distorted very considerably. This trouble was overcome by the substitution of a high tensile steel core for the plain carbon core, which was too weak.

It should be mentioned here that the cores of the case-hardened parts show, very clearly, the effect of quenching upon the elastic limit of those steels which harden at all drastically. The final act in the treatment of case-hardening steels is to quench them out from the hardening temperature of the case, usually in water. It seems reasonable to assume that, in consequence of this drastic hardening, the steels are in the condition of having considerable quenching strains locked up in them, and that, therefore, they will show a low value for the apparent elastic limit. That this assumption is correct is shown by the results given in Table 61.

The misleading nature of the elastic limit, determined in the usual way, is also shown by the results of the fatigue range determinations which are given in the parallel column. It is instructive to notice that those plain carbon case-hardening steels which have only a comparatively low strength, do not exhibit such a considerable difference between their apparent elastic limit and fatigue stresses.

which, therefore, harden in a comparatively intense manner. It is reasonable to expect to find more considerable evidence of quenching strains in these harder steels than in the plain carbon steels which do not harden so intensively.

TABLE 61.

THE ELASTIC LIMITS AND FATIGUE RANGES OF DIFFERENT CASE-HARDENING STEELS.

Steel.		Elastic Limit, tons per sq. in.	Ultimate Strength, tons per sq. in.	Fatigue Range, tons per sq. in.
Plain carbon, low manganese ..	(2) <sup>1</sup>	17.25	40.3	± 18.4
Plain carbon, high manganese	(1)	15.3	38.0	± 17.3
3 % nickel .. .. .	(3)	18.0	66.2	± 31.0
5 % nickel .. .. .	(4)	16.0	63.2	± 30.0
6 % nickel .. .. .	(7)	20.0	51.7	± 26.5

#### DISTORTION OF CASE-HARDENED OBJECTS.

Distortion occurs to a considerable extent during all the operations carried out in the case hardening of steel. This is inevitable from the considerations given in the chapter on Heat Treatment. In the ordinary way, it is not likely that any serious distortion will take place during the process of carburising, unless the articles which are being carburised are packed so badly that they distort under their own weight in the carburising box, or unless they are machined parts in which unrelieved mechanical strains due to machining, cold working, or forging, existed, the removal of which, by the heat, caused the change of shape. After removal from the carburising box, the parts are heated to a comparatively high temperature, very much higher than the critical, and then are frequently quenched. This treatment almost always results in a certain amount of distortion, and the

<sup>1</sup> The figures in brackets refer to the composition of the steels given in Table 51.

most careful precautions must be taken to prevent the amount from becoming serious. After this first quenching to refine the core, the articles are re-heated to a lower temperature, and once again quenched. Since they are hardened during the second operation (completely in the case and partially in the core), an additional distortion may take place, or, by very good and unusual luck, the original distortion may be partially neutralised.

In consequence of the repeated quenching from temperatures higher than the critical, the opportunities for distortion, provided by the treatment of case-hardening steels, are greater than those found in the treatment of any of the other types of steel. Case-hardened parts lend themselves to an exaggeration of the volume changes which occur during the quenching of all steels. On p. 75, the action of expansion and contraction in producing strains in articles which are being hardened has been indicated, and, in the same section, the serious effect of the critical volume changes which occur during the heating and cooling of steel have also been dealt with. When case-hardening steels are being treated, the possibilities of cracking and distortion are increased, not only by the drastic nature of the treatment, but also by reason of the fact that the case and the core differ so distinctly in composition, and, therefore, in their other characteristics. The case, which is the hardest and, therefore, the strongest part of the case-hardened article, is quenched first, and, therefore, becomes rigid during the quenching operation sooner than any other part. As a result, the tendency for the case to adjust itself to the contractions which are taking place in the layers below the surface, is much less than it might be in the corresponding portion of a piece of steel which was of the same composition as the case throughout, and which hardened to the same strength in every part.

The effect in producing distortion, resulting from differences in the mass of various parts, may be expected to be greater in a case-hardened article than in a non-case-

articles do distort to a greater degree. The additional effect of the existence of two distinct portions—the core and the case—in producing distortion, comes into play when the nature of these parts is considered. It has been explained that the volume changes which occur during the heating and cooling of steel are influenced, to some extent, by the composition of the steel. A low carbon steel suffers more sudden expansion, when cooled through the critical temperatures, than a high carbon steel. Sudden changes of density occur at those temperatures at which the steel undergoes constitutional alterations. If the steel retains, down to low temperatures, the constitution which it possesses at high temperatures, there is no abrupt change of density or volume during the cooling. That portion of a case-hardened article which is most likely to retain the constitution which it possesses at high temperatures is the case, first, because this is quenched most rapidly, and, second, because its composition tends to produce a more stable solid solution. The case, therefore, may be presumed to undergo comparatively little change of volume during cooling. The core, on the other hand, is very rarely completely hardened, except in very small parts, and, therefore, is likely to undergo a change of volume, more or less suddenly, during the cooling process. It is evident, therefore, that the two parts of the case-hardened article are not acting together, and it is difficult to imagine how distortion, or, what is worse, occasional cracking, can be completely avoided.

There is no golden rule for the avoidance of distortion in case-hardening steels, since almost every part must be treated upon its own merits. It is only by the application of common sense that the various troubles can be overcome. There are, however, certain points which should be observed in the treatment of all articles. These have been generally indicated in the section on hardening. In the first place, it is absolutely essential that

great care should be taken to heat the parts throughout to a uniform temperature before they are quenched. Unless this is done, distortion is bound to take place, and cracking is almost sure to follow, unless the shape of the article is such as automatically tends to avoid cracks. Sufficient time must, therefore, always be allowed for the article to be heated to the same temperature, from the outside to the centre. The second point of importance is to arrange for the article to be dipped into the quenching fluid in such a way that parts, which are placed similarly with respect to the axis of the piece, reach the quenching fluid at the same time. It is not possible, in view of the tremendous variety in the shape of case-hardened articles, to enlarge much upon this point, but the rule should be well laid to heart. Most machined parts are symmetrical about some axis, and, in general, this axis should enter the quenching medium vertically, and not horizontally or obliquely.

It should be unnecessary to state that case-hardened articles should never be quenched from a higher temperature than is really necessary. In Table 58, the correct hardening temperatures, for parts of normal size made of the different steels, are shown, and these should be adhered to. If this temperature is exceeded, the hardening becomes too drastic, and contraction and expansion changes become greater, and, in consequence, the distortion is increased considerably.

A point which cannot be insisted upon too frequently or too strongly, is the need for avoiding all sharp corners, grooves, notches, or sudden changes of radius, in articles which have to be quenched in the drastic manner common to case-hardening steels. The presence of these defects in case-hardened articles is responsible for a very large proportion of the cracked parts which are produced in many works.

A certain amount of distortion, really a normal change of specific gravity, always occurs during the quenching of steel. This has been explained on p. 80, and needs to



be referred to again, since it is what might be called permanent distortion, and should be expected by the operator. In case-hardened articles it is not desirable, and, in some cases, not possible, to correct this distortion (which is an expansion) by grinding off the case. It is, therefore, necessary for the engineer to take account of this alteration of dimensions, when machining the part which is to be case hardened, and to carry out the carburisation upon an article slightly under size, so that when the article expands during quenching, it will fill out to the correct dimensions.

It has often been found desirable to correct the distortion which takes place during the refining operation, by grinding the articles approximately to size before carrying out the final hardening. This has the effect of releasing a proportion of the strains put in during the refining operation, and it also has the effect of causing less grinding to be required after the final hardening. Another way to avoid distortion, is to cool the articles in air during the refining operation, rather than to quench them in a liquid, as is so generally done. The practice of air hardening a case-hardened article is also of importance, as, by this treatment, the distortion produced in the hardening of the articles is reduced to a minimum. If air hardening be employed, the various effects, given above, of this process upon the core, must be taken into account.

#### DEFECTS IN CASE-HARDENING STEELS.

Case-hardening steels are not very easy to manipulate, and the case-hardening operations may easily go wrong. It is not possible, within the confines of a single chapter, to indicate all the possibilities of failure in connection with case-hardened parts, or to indicate what steps should be taken to overcome them. One or two of the probable defects which arise may, however, be mentioned, and the causes of these defects roughly indicated.

One of the most troublesome causes of failure in case-hardening steels is the existence of soft spots. These

may arise from various causes. They may be produced by the fact that the steel, at the point where the soft spot occurs, has not been properly carburised, though this is one of the least common reasons. They may also be produced because the part in question has not been properly hardened or quenched, which is a very much more usual cause. Insufficient hardening may arise from various causes. The first is the uneven heating of the part. If the case-hardened part has not been heated as high as the correct temperature for hardening, many soft spots are bound to be discovered in it after the quenching has been carried out. If the heating has been uneven, the hardening will probably be satisfactory at one point, but insufficient at another. A second reason for the insufficient hardening is that the part may not be properly quenched, in consequence of the fact that it has not been fully exposed to the cooling effect of the quenching fluid. This occurs more frequently than is generally imagined, and it is not possible to give a general reason for its occurrence, or how it is to be avoided. It is only possible to indicate that this is one of the causes of soft spots, and to say, that the operator in charge of the hardening operations must take pains to determine what is the safest way to ensure that the quenching fluid gets immediate access to all portions of the surface of the parts that are being quenched. A third cause of soft spots due to insufficient hardening is the quenching of several parts together. When this is done, it is not unusual for two parts to come into contact, and to enter the quenching fluid at the same time whilst in contact. This usually means that they protect each other from complete access to the liquid.

Flaking off of the case is another cause of trouble in case-hardened parts. This is a matter of considerable importance, and the fault may arise from several causes. One such cause is over-carburising. If a steel is carburised too heavily, a certain quantity of free iron carbide is certain to be produced in the outer skin (see Fig. 84).

This free carbide acts as a generator of small cracks, and also permits, and causes, cracks to spread underneath the case. After a time, the spread of these cracks results in the dropping away of a portion of the surface of the case-hardened part. Sometimes it results in the spreading of the crack throughout the part, with destructive results. In Fig. 85 is shown a cross-section of a gear-wheel tooth, in which cracks have been set up throughout the body of the tooth, in consequence of the presence of an excess of iron carbide in the outer layers of the steel.

Another fault, closely allied to flaking, arises from the existence of unduly large slag streaks in the steel. If the steel contains any quantity of slag, which is in the form of drawn-out streaks, trouble will sooner or later result. The slag may lie on the surface of the machined part, and, therefore, upon the outside of the case. During the operation of carburising, the slag usually is not affected, but, during the operation of refining or hardening, it is possible for it to fall out, or to start a crack. Even if trouble does not occur in this way, it usually arises when the part is put into use. Since case-hardened surfaces are customarily exposed to abrasive forces, the slag is not infrequently removed by rubbing during the early operations. This opens up the surface of the steel, and, as a result, the part is rapidly ruined. The slag in other parts may lie a little way below the surface, and, since it is only covered by a very thin layer of steel, may cause failure by the cracking of the layer of steel covering the slag streak after the article has been in use for some little time. Unnecessary slag in case-hardening steels is a considerable nuisance, and should be avoided as far as possible.

Another trouble which arises in case hardening is the fact that the core of the part is sometimes unusually weak. This is generally due to the mass effect in hardening. It is of the utmost importance that this effect should always be appreciated and attended to by the engineer.

## PREVENTION OF CARBURISING.

It is frequently necessary to avoid the carburisation of some part of the surface of an article, since it may not be desirable to have the whole of the surface of the finished article hard. There are several ways of avoiding the carburising of portions of the surface of the finished article. In the first method the whole article is carburised, but only after those surfaces which are required to be hard, in the final article, have been machined to size. Those portions of the article which are not required to be hard are left large, and are machined to size after the part has been carburised, but before it has been refined or hardened, thereby removing the case from the surfaces which are expected to be soft. This is very often the most satisfactory method of procedure, but for quite a number of parts it is not practicable.

Another method of avoiding the production of a case, is to cover that part of the article, which is not to be carburised, with some surface layer which will prevent the absorption of carbon by the steel. One of the most usual methods of doing this is to plate the surface of the steel with copper or with nickel. Either of these two methods can be employed quite easily, the metal being deposited electrolytically. It is necessary to deposit a fairly thick layer, if carburisation of the underlying surface is to be prevented. During the operation of electroplating with either copper or nickel, the surfaces which are subsequently to be carburised should be protected from the action of the plating, by smearing with vaseline or with some other form of non-conducting grease.

Another way of preventing the carburising is to paint that part of the surface which is not to be carburised with a suitable enamel, and then to cover the enamel with a paste of fire clay. The fire clay should be allowed to dry completely before the articles are packed in a carburising box.

Yet another method which may be employed for pre-

venting carburisation of the surface is to coat the surface with a mixture of waterglass and fine sand, which should be allowed to dry before the articles are put into the carburising box. Any of these methods will give satisfaction. The last method probably is the best, if it is carried out properly, though the method of electro-plating can be strongly recommended if the plant is available.

The prevention of hardening the surface (which has been carburised) is often attempted by covering, with fire-clay paste, those parts of the article which are not to be hardened. The articles under these circumstances are coated with the paste after the refining operation has been carried out. The paste is then allowed to dry, and is baked slightly before the articles are put into the furnace. After heating in the furnace, they are treated in the usual way, and quenched as though the coating were not present. The result is that the covered part of the article may be cooled sufficiently slowly to prevent its being hardened appreciably.

## CHAPTER VIII

### COLD WORKED STEELS

To the engineer, cold worked steel is of great importance, probably greater than he ever suspects. He uses a considerable quantity of bright drawn bar for the manufacture of many comparatively unimportant parts, particularly those made in automatic machines. He uses sheet and strip for making cold pressings, thereby utilising steel which has probably been cold worked during rolling down, and he cold works it himself in the process of making the pressings. All the wire which he employs, if of small size or of high tensile strength, has been cold drawn. The rims and spokes of wheels for motor-cars and bicycles are almost always made from cold worked steels. A large proportion of the tubes used by engineers are cold drawn. More examples might easily be given. The reason for the cold working of these different steels is not always the same. The bright bars for machining are usually cold drawn, in order to produce a steel which has a clean bright surface, and which, in consequence, causes comparatively little wear on the tools. The cold-drawing process also produces a bar of very uniform size—with a regular and small tolerance on the dimensions—which is, therefore, more suitable for use in automatic machinery. In such material the cold working is of comparatively little importance, in so far as the mechanical properties of the steel are concerned. Sheets are often cold rolled, because it is more economical and simple to treat them in this way than to carry out the whole reduction in thickness

by rolling hot metal (this applies particularly to sheets of small thickness). Wire, and structural cold worked steel of that kind, is cold worked in order to produce a steel having a high strength, together with a high degree of uniformity in dimensions. All the processes, however, have points in common.

The operation of cold working of steel is always accomplished, either by rolling the metal through powerful rolls or by drawing it through hard dies. The latter method is employed for wire, and for bars of less than, approximately,  $\frac{3}{4}$  inch in diameter. Larger bars are drawn, but not very frequently. The other forms of cold worked material are most frequently rolled. Whichever process is employed, the hot rolled steel is first of all pickled to remove all scale, and is then forced through rolls, or dragged through dies, so that the dimension of the steel, perpendicular to the direction of rolling or drawing, is thereby reduced considerably. The amount of reduction of cross-sectional area, suffered by the steel in the cold-working operation, varies a good deal with the nature of the work which is being treated, and with the objects of the treatment. If the steel is simply being "bright drawn" in order to produce bright bars for machining, the reduction of section may be quite small, being perhaps about  $\frac{1}{32}$  inch on the diameter of bars of about  $\frac{1}{2}$  inch in diameter to  $\frac{1}{16}$  inch on bars of about 2 inches in diameter. If, on the other hand, the steel is being cold worked in order to increase its strength considerably (as in wire drawing), the reduction of section may be quite large, up to 30 per cent. or even more. After the steel has been worked to the full extent that is desirable, in consequence of the great change of mechanical properties induced by the cold work (see below), it is heat treated in order to soften it, and so make it fit for further cold working. This heat treatment is usually termed annealing, but it is often carried out at temperatures below the lower critical change-point (see below). It may, on the other hand, be simply a normalising operation.

In other cases the steel is truly annealed. After the softening heat treatment the steel may be pickled, though this operation may be unnecessary if the annealing process has been so conducted that the steel is not scaled, and is then worked again. The alternate processes, of cold working and softening, are repeated until the full reduction of cross-sectional area that is desired, has been accomplished. The steel is not usually softened after each pass through the rolls or the dies. The working is customarily arranged so that the steel will withstand several passes between successive softenings. This simply means that the amount of reduction in each pass is comparatively small, i.e., so that several small reductions are made, in place of one large one. Variations in this procedure are a distinct part of the art of the manufacturer of cold worked steels.

It will be most convenient to describe, first of all, the effect of cold working upon the mechanical properties of steel. The foremost effect is that the cold work increases the strength of the steel, and, at the same time, reduces its ductility. This alteration of properties is progressive, that is to say, the greater the reduction of area, the greater will be the change produced in the mechanical properties. The effect of the cold work upon the mechanical properties of the steel can be well seen from the figures given in Table 62 and the curves in Fig. 86.

TABLE 62.

EFFECT UPON THE MECHANICAL PROPERTIES OF THE STEEL OF DIFFERENT DEGREES OF COLD WORK.

Reduction of Cross- Sectional Area, %	Max. Stress, tons per sq. in.	Elongation, %	Reduction of Area, %
—	31.0	29.9	59.5
9.1	40.0	13.2	49.1
15.4	43.5	9.3	43.3
22.6	46.5	4.5	39.2
28.3	47.5	4.5	25.4



There is hardly any limit to the degree to which the steel can be strengthened by the continued application of cold work. In practice, the limit is reached at a comparatively early stage, in consequence of the immensely decreased ductility, i.e., increased brittleness, produced by the drawing or rolling. It can be seen from Fig. 86 that, after a heavy reduction in area, the elongation and

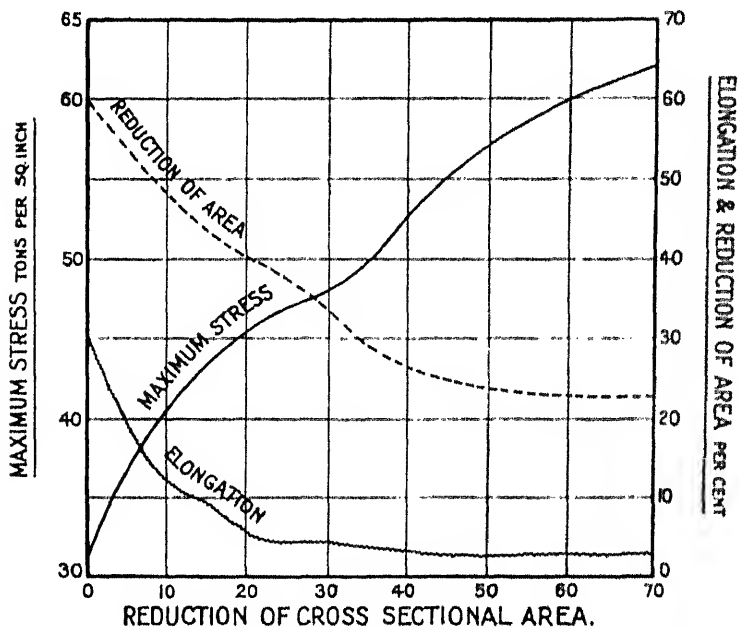

FIG. 86.—CURVE SHOWING THE CHANGES IN THE MECHANICAL PROPERTIES OF A STEEL PRODUCED BY VARYING AMOUNTS OF COLD WORK.

reduction of area given by the steel become exceedingly small, which means that any further drawing is likely to cause the steel to break up during the process. The art of the manufacturer of cold worked steel, mentioned above, lies to a considerable extent in his ability to provide a high strength, together with a reasonably high ductility, in the cold worked steel. This will be referred to again.

The cold worked steels are susceptible to heat treatment, just as steels hardened in other ways are, but the cold worked steels present some features not met with in the treatment of the other steels. It will be advisable, therefore, to deal with the subject of the heat treatment of the cold worked steels as a whole. The first set of figures to be presented, shows the effect upon the mechanical properties of steel of heating it, after cold working, to temperatures between room temperature and 700° C., i.e., to temperatures the highest of which is slightly below the critical temperature of the steel. It has been demonstrated in connection with the operation of tempering (see p. 60), that an examination of the change of mechanical properties is one of the best ways of illustrating the effect of heat treatment. The results of the tensile tests made upon this series of re-heated, cold worked, specimens are shown in Table 63 and in Fig. 87.

TABLE 63.

EFFECT OF RE-HEATING OR BLUEING UPON THE MECHANICAL PROPERTIES OF A COLD WORKED STEEL.

Blueing Temperature ° C.	Elastic Limit, tons per sq. in.	Max. Stress, tons per sq. in.	Elongation, %	Reduction of Area, %
—	27.1	70.2	5.0	18.0
100	27.3	71.0	5.0	18.0
200	43.4	77.0	5.0	19.0
300	46.1	74.1	3.0	18.0
400	51.6	72.9	9.0	37.0
500	44.4	61.6	11.0	40.0
600	38.0	47.2	17.5	47.0

For the sake of complete clarity of expression, it is desirable to differentiate between the process of re-heating a steel which has been hardened by quenching, from that of one hardened by cold work. The former treatment is known as tempering, and as been described quite fully

in Chapter III. The latter process is known as "blueing," though it should be added that this denomination is usually reserved for treatments at temperatures below  $550^{\circ}\text{C}$ .

The figures in Table 63, and the curves in Fig. 87, show

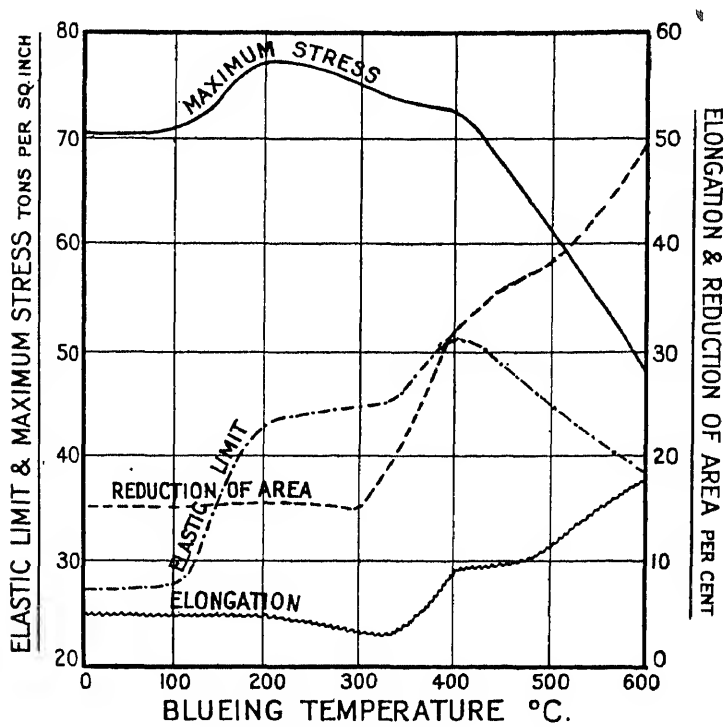

FIG. 87.—THE CHANGES IN THE MECHANICAL PROPERTIES OF COLD WORKED STEEL PRODUCED BY BLUEING AT DIFFERENT TEMPERATURES.

that blueing has a distinct effect upon all the mechanical properties of the steel. The maximum stress rises, slightly, up to a maximum at about  $400^{\circ}\text{C}$ ., and then falls off, slowly at first, and afterwards more rapidly, at temperatures between  $500^{\circ}\text{C}$ . and  $575^{\circ}\text{C}$ ., the fall of strength

becoming very much slower and almost disappearing at temperatures above  $575^{\circ}\text{C}$ . The curve for the yield-point (which is very difficult to observe in these steels) more or less follows that for the maximum stress, the two curves being parallel. The elastic limit, as given by the limit of proportionality shown by the most careful extensometer readings, takes an independent path. In the fully hardened material the elastic limit is quite low, and, as the blueing temperature rises, the elastic limit also rises, and does so fairly rapidly, the maximum value being recorded in steels blued at temperatures of from  $350^{\circ}\text{C}$ . to  $400^{\circ}\text{C}$ ., depending upon the particular sample under test. The curves for the ductility values show practically no change until the re-heating temperature passes  $400^{\circ}\text{C}$ ., after which there is a steady and normal increase in the values, with a rise in the temperature of blueing up to  $575^{\circ}\text{C}$ .

A most striking similarity exists between the curves displayed in Fig. 87, for the effect of re-heating or blueing upon the mechanical properties of the cold worked steels, and those in Figs. 63 and 64, for the tempering of the oil- or air-hardened alloy steels. The actual temperatures, at which the principal changes occur, are not quite the same in the two types of steel, but the general form of the curves is very similar for both kinds of material. The resemblance is particularly evident and important, in connection with the elastic limit. The exceedingly low elastic limit in the fully cold worked material is of great interest, and, when the difference between the natures of the cold worked steels and the quenched steels is considered, the similarity as regards this property becomes still more striking.

In addition to the tensile test, it is fairly usual to test cold worked steels by the reverse bend test (as well as by the plain bend test, which calls for no discussion). The reverse bend test values are affected quite appreciably, by the temperature of blueing, some typical figures being given in Table 64.

TABLE 64.

THE EFFECT OF BLUEING UPON THE REVERSE BEND  
VALUES OF A COLD WORKED STEEL.

Blueing Temperature °C.	Reverse Bends.
—	9
100	8
200	7½
300	6½
400	7
500	9
600	20

The results given in Table 64 show that, when the steel is blued at those temperatures which produce the best combination of values of maximum stress and elastic limit, the reverse bend values depreciate markedly. The amount of depreciation is not the same for every steel, but it can be regarded as a fact that blueing these steels in the region of 300° C. to 400° C. seriously increases their brittleness.

It is suitable now to indicate the reasons for the change in mechanical properties, of a cold worked steel, produced by re-heating, so far as they are revealed by the structural changes which the steel undergoes. A cold worked steel which has not been blued in any way has a micro-structure consisting of crystals very considerably distorted (see p. 88). The distortion of the crystals is more or less uniform throughout the mass of the steel, and the degree of distortion is more or less proportional to the extent to which the steel has been cold worked. It is chiefly evident in the ferrite of the crystals, i.e., in the excess iron thrown off by the steel during its cooling through the critical range (see p. 47), but, if the amount of cold working has been very great, the distortion extends to the particles of carbide which, being brittle, are not merely stretched and twisted, but actually broken up into frag-

ments (see Fig. 89, which shows the way in which the carbide may ultimately be arranged). On re-heating a steel having the structure shown in Fig. 88, there is no change in the structure until the temperature of the steel has been raised to a considerable height. There is some controversy regarding the actual temperature at which the first change of structure occurs, and also regarding the way in which that temperature is affected by the degree of cold work to which the steel has been subjected. This controversy is somewhat academic, and of little real interest to the engineer, who will not be misled, appreciably, by assuming that the temperature, at which the first noticeable structural change occurs, is constant for all plain carbon steels, however worked, and that this temperature is very nearly  $525^{\circ}\text{C}$ . At this temperature the steel undergoes a very definite change of structure, that change being really a re-crystallisation. It seems to be definitely established that the first structural change is a splitting up of the distorted crystals into a much larger number of very small crystals free from distortion. The disintegration is followed by the gradual coalescence of these tiny crystals into larger crystals free from distortion, and approximating in form to the structure of the crystals possessed by normal steels. (The early stages of the splitting up are shown in Fig. 90 and the coalescence stage in Fig. 91.) These structural changes occur comparatively rapidly, the speed of the re-crystallisation depending considerably upon the temperature of the steel. This means that the complete change will occur at the minimum temperature of about  $525^{\circ}\text{C}$ ., if the steel is retained at that temperature for a sufficient length of time. At higher temperatures the changes occur more rapidly. With a normal period of heating the changes are completed within a temperature range of approximately  $50^{\circ}\text{C}$ . A comparison of the figures, as given in Fig. 87, for the mechanical properties produced by blueing at the different temperatures, with the description of the re-crystallisation just given, shows the correspondence

between the changes of structure and the alteration in mechanical properties. The comparison shows that the whole mechanical effect of cold work has been removed, and a complete structural transformation has been effected by heating the steel to a temperature of about 575° C.

Earlier in the chapter it was stated that, during the manufacture of cold worked steel, the metal was softened, when a certain amount of working had been accomplished, so that the steel should be in a fit condition to withstand subjection to further cold work. It was stated that this softening is sometimes effected by normalising, and, at other times, by heating to a temperature below the carbon change-point of the steel. The justification for this second method of softening can be seen from the account of the structural changes produced by blueing, outlined above. By blueing, the steel has really become softened, i.e., it has been treated so that all the strength and hardness, produced by cold work, has been removed, and the ordinary degree of ductility has been restored to the steel. This is accomplished when the steel has been heated to a temperature of, approximately, 600° C. By heating the steel to still higher temperatures, additional changes of structure can be produced in the steel, which make it even better for subjection to cold work, although the ordinary mechanical properties of the steel, as revealed by the usual tests, are not very much altered. The further changes are induced by heating the steel to a temperature of about 650° C. to 675° C., and maintaining it at this temperature for a fairly prolonged period. The structural change produced by this treatment is the assumption by the carbide of a globular state, the globules being distributed through the mass of the steel very evenly. The actual distribution obtained is akin to that produced in a steel which has been hardened by quenching, and then tempered at this same temperature of 650° C. for a fairly prolonged period. The structures of the same steel, first after normalising, and, secondly, after cold working and

re-heating to 650° C., are given in Figs. 92 and 93, and it is evident that the steel after re-heating to 650° C. possesses a much more homogeneous structure than after normalising. The carbide is distributed exceedingly evenly in the ferrite, and it can be imagined that a steel with such a constitution presents the maximum degree of ductility, and also possesses a structure which can be most readily distorted by subsequent cold work, and, therefore, is capable of being worked to a great extent without cracking, etc. The hard and brittle carbide is embedded in a soft and yielding matrix of iron.

The operation of heating a cold worked steel to a temperature below the carbon change-point, for the purpose of softening it, is usually termed annealing. This, of course, is an abuse of the term. A reference to the definition of annealing given on p. 39 and to the description of the process, will show at once that the practice of heating the steel to 650° C. is definitely not annealing. The process is really one of high temperature blueing, or high temperature tempering, and really requires a definite name for itself. In view of the effect which the process has upon the carbide, i.e., making it coalesce into globules, the term "globularising" is used in this book for want of a better.

Despite the frequent use of the process of globularising, the condition which it produces within the steel is not really satisfactory, particularly after further cold work has been put upon the steel. The globular carbide in the steel sometimes tends to the production of brittle material when it is cold worked, and it is, therefore, preferable to utilise a normalising operation for the final heat treatment, i.e., before the last passes, whether globularising has been employed for the previous softenings or not.

Whilst speaking of the methods for the heat treatment of the steel, prior to, and between, the passes of the cold



ising temperature (e.g., 550 °C. to 1,000 °C.), and cooling it in air. The process is therefore a form of normalising. The most usual way of carrying out the treatment is a continuous one. The patenting furnace is a long, open-ended chamber, fired in such a way that the steel is heated gradually up to the required temperature whilst being passed through the furnace. When the treatment is applied to wire or to coiled material in general, the steel is pushed through the furnace (which may be anything more than 20 feet in length), fixed to the coiling machine at the further end, and then pulled through the furnace by this machine. The steel cools quite freely and rapidly from the temperature which it reaches, and attains a fairly characteristic structure. The excess of iron (or ferrite) in the solid solution is thrown out round the crystals. As the steel is originally at a fairly high temperature, the crystals are moderately large, and the precipitated iron has a rather acicular structure. The pearlite (eutectic) when it separates, does so while the steel is passing through the critical change-point at a moderately rapid rate, with the result that the particles of carbide are quite small, and finely distributed through the body of the eutectic. The steel is absolutely free from well-formed or large particles of free carbide, and finally consists of crystals, the cores of which are very finely divided pearlite (usually known as sorbite), while the envelopes are ferrite in a fairly massive form (see Fig. 94). This is to be expected from the fact that only the earliest part of the cooling takes place in the furnace (allowing therefore the ferrite to separate), while the later part of the cooling, through the carbon change-point, is relatively rapid since the steel is in the open air (therefore producing very finely divided pearlite or sorbite). Such a structure is capable of receiving a considerable amount of distortion with comparative ease and freedom from failure—the ferrite envelopes distorting freely, while the cores, being free from massive carbide, have a mobility that is not found

in pearlite in which the carbide is present in comparatively large masses.

The composition of the steel which is cold worked is naturally of considerable importance in determining the mechanical properties of the finished worked material. This applies equally to the bright drawn bars used in automatic machinery. The effect of the composition is quite easy to understand, and will be treated purely from the point of view of the engineer, who wishes to appreciate the principles underlying the specification which should be drawn up for this type of steel. The process of drawing, or cold rolling, produces a definite reduction in the cross-sectional area of the steel. This reduction of sectional area produces, equally definitely, an increase in the tensile strength of the steel and a decrease in its ductility, i.e., its elongation and reduction of area. For purposes of illustration it may be assumed that a reduction of cross-section of 12 per cent. produces an increase in strength of, say, 10 tons per square inch, and a reduction in elongation of 15 per cent. (A reduction in cross-sectional area of 12 per cent. corresponds roughly to the removal, by drawing, of  $\frac{1}{32}$  inch from an  $\frac{1}{2}$ -inch rod.) It may also be assumed for the present, that under any such specification as is contemplated, the finished drawn rod, furnished to that specification, would be expected to be of the same approximate tensile strength, whether the steel is  $\frac{1}{2}$  inch diameter or 2 inches diameter. If the steel were all of the same composition, and the reduction of cross-section were the same for all sizes, the increase in strength and the drop in elongation would be practically the same on each bar, and the same consequent mechanical properties would be obtained. To obtain this constant reduction of cross-section, however, would mean the displacement of a very considerable thickness of metal when drawing the larger sizes of bar. A reduction of area of about 12 per cent. on an  $\frac{1}{2}$ -inch rod, means a reduction in diameter of about  $\frac{1}{32}$ , i.e., from  $\frac{1}{2}$  inch to  $\frac{1}{4}$  inch. A similar reduction on the 2-inch rod would mean a dimi-

reduction of diameter of  $\frac{1}{8}$  inch, which is absolutely large, is required in practice. The reduction which is effected in practice for the larger sizes of rods, is rarely more than  $\frac{1}{16}$  inch, which means a reduction of cross-section of about 5 per cent. Such a reduction would produce an increase of only about 4 tons in the tensile strength. Evidently, then, to obtain the same tensile strength in the finished rod in the large and the small sizes, the larger rods must be initially of a higher strength than the smaller, and, therefore, must be of a suitably different composition, i.e., higher in carbon, than the smaller rods. A suitable gradation of carbon content for the different sizes of bars, assuming the same range of strengths in the finished bars, is given in Table 65.

TABLE 65.

THE EFFECT OF DIAMETER UPON THE CARBON CONTENT OF BRIGHT DRAWN STEEL BARS.

Size of Bar, Diameter or Width across the Flats.	Carbon, % <sup>1</sup>
Up to $\frac{1}{2}$ inch	0.15 to 0.25
Over $\frac{1}{2}$ inch up to 1 inch	0.20 to 0.30
Over 1 inch up to 2 inches	0.25 to 0.35
Over 2 inches	0.30 to 4.45

A point of intense importance to the engineer is the assurance that the steels used for drawing shall have, initially, a sufficiently high carbon content to produce the strength required in the drawn steel without the application of too much cold work, i.e., too great a reduction of cross-section. It was shown quite early in this chapter that it is possible to increase the strength of a steel considerably by continued drawing, but that by so doing, the ductility of the steel, as measured by the elongation and reduction of area, is adversely affected. In other words, as shown imme-

<sup>1</sup> The range of maximum stress for these bars is 35 to 42 tons per square inch.

diately above, every reduction of cross-section increases the strength of the steel by a definite proportion, and, at the same time, reduces the elongation by a definite proportion. If, therefore, the steel is of such a composition that the customary reduction of cross-section does not produce the requisite increase in strength, the deficiency may be made up by a further reduction of cross-section, i.e., further drawing, but the increased strength can only be obtained at the expense of the ductility of the steel. Unfortunately, this practice of further drawing is resorted to only too frequently, with the result that large quantities of "overdrawn" steel are produced, and frequently used by the unsuspecting engineer.

The ultimate result of overdrawing is the breaking down of the steel. "Cupped wire" is produced in this way, but the form of failure giving rise to the name is not confined to wire, and is found at times in quite large rods. A typical failure is seen in Fig. 95. It is evidently of the first importance that the steel shall possess a suitable carbon content, i.e., a suitably high initial strength, before drawing, in order to avoid overdrawing, even in its most simple forms.

One of the greatest values of bright drawn steel is the fact that it can be obtained to a definite and specified size within quite fine tolerances. The British Standard tolerances for such steel are given in Table 66.

To some extent, the attainment of these tolerances depends upon the existence of reasonably accurate tolerances in the black bar from which the bright steel has been produced. Naturally, the margins of manufacture on hot rolled bars are very much greater than those for bright drawn bars, but it is often found that, besides being very seriously larger, they vary considerably in different parts of the bar, and even on the same length of bar measured on different diameters. Many instances of unevenness in the mechanical properties of bright drawn

**Fatigue Range of Cold Worked Steels.**—The fatigue range of the cold worked steels is important information to the engineer. Various tests<sup>1</sup> have been made upon a cold worked steel both before and after blueing, and the results which have been obtained are shown in Tables 67 and 68, together with the results of the ordinary tensile tests upon the same material.

TABLE 66.

## BRITISH STANDARD TOLERANCES ON BRIGHT DRAWN STEEL BARS FOR AIRCRAFT.

Nominal Size of Bar (diameter or width across the flats), inches.		Tolerance, inches.	
Round and Square.	Hexagon.	Plus.	Minus.
0·010 to 0·039	—	0	0·001
—	0·010 to 0·039	0	0·001
0·039 to 0·5625	—	0	0·002
—	0·039 to 0·525	0	0·002
0·5625 to 1·125	—	0	0·003
—	0·525 to 0·920	0	0·003
1·125 to 3·0	—	0	0·004
—	0·920 to 3·0	0	0·004

The results in Tables 67 and 68 show, quite conclusively, that the fatigue range of the steel is independent of the elastic limit of the metal, as shown by the ordinary determinations of the limit of proportionality in a tensile test. The results show also that the fatigue range bears the same relationship to the maximum stress in the cold worked steels, as in the hardened and tempered plain carbon or alloy steels, the ratio being about 0·95 to 1. This ratio holds good, whether the steel has been cold worked, or whether it has been subsequently blued. The results are of considerable importance.

<sup>1</sup> *Report of Materials Section, Air Ministry.* H.M. Stationery Office, 1921.

SHOWING THE MECHANICAL PROPERTIES IN TENSION AND

FATIGUE OF A STEEL CONTAINING

CARBON	..	..	..	..	0.26	per cent.
SILICON	..	..	..	..	0.05	„
MANGANESE	..	..	..	..	0.54	„
SULPHUR	..	..	..	..	0.031	„
PHOSPHORUS	..	..	..	..	0.027	„

AS DRAWN AND AFTER BLUEING AT DIFFERENT TEMPERATURES.

Blueing Temperature ° C.	Elastic Limit, tons per sq. in.	Yield-point, tons per sq. in.	Max. Stress, tons per sq. in.	Elongation, %.	Reduction of Area, %.	Fatigue Range, tons per sq. in., Wöhler.
—	18.2	36.8	40.8	13.3	52.6	±19.1
250	20.5	36.6	40.1	15.0	52.6	±18.4
400	28.1	28.4	39.9	16.6	50.0	±19.0
550	25.0	26.4	36.8	23.3	52.6	±18.0

TABLE 68.

SHOWING THE MECHANICAL PROPERTIES IN TENSION AND  
FATIGUE OF A STEEL CONTAINING

CARBON	..	..	..	..	0.25	per cent.
SILICON	..	..	..	..	0.08	„
MANGANESE	..	..	..	..	0.68	„
SULPHUR	..	..	..	..	0.051	„
PHOSPHORUS	..	..	..	..	0.043	„

AS DRAWN AND AFTER BLUEING AT DIFFERENT TEMPERATURES.

Blueing Temperature ° C.	Elastic Limit, tons per sq. in.	Yield-point, tons per sq. in.	Max. Stress, tons per sq. in.	Elongation, %.	Reduction of Area, %.	Fatigue Range, tons per sq. in., Wöhler.
—	18.2	26.1	36.2	20.8	54.1	±17.0
250	20.5	31.2	38.4	22.5	50.2	±17.2
400	25.0	30.5	37.9	20.0	50.1	±17.0
550	20.5	27.2	35.2	28.3	52.6	±15.7

## CHAPTER IX

### TOOL STEELS

THE steels from which the modern engineer manufactures cutting tools can be divided into two fairly well-defined classes, namely, high speed and otherwise. These two groups are quite distinct in themselves. The high speed group has very few sub-divisions, but the "otherwise" group divides itself into a very considerable number of types. This group contains those tool steels which have been in use for a very long time, and includes the plain carbon steels, together with those steels which contain a certain small quantity of tungsten or of chromium, or a mixture of small proportions of both elements, with possibly a pinch of vanadium in addition. It also contains the cutlery steels (those used for razors, carving-knives, etc.), and the steels used for many fine tools. As a general rule, it may be said that all the steels in this class contain a fairly high proportion of carbon, and that the hardness of the tools is obtained as a result of the high carbon. If the alloying elements mentioned above are present, they are usually found only in such proportions as do not produce any appreciable difference between the fundamental properties of the alloy and the carbon steels. The actual proportion of carbon in the tools varies according to the nature of the work which they have to perform, a fairly representative list of compositions being given in Table 69. The finer and more delicate the tool, the higher is the proportion of carbon, as might be expected.

TABLE 69.

## THE CARBON CONTENT OF DIFFERENT PLAIN CARBON TOOLS.

Tool.	Carbon Content.
Razors, very special lathe tools .. ..	1.3 to 1.4 per cent.
Turning tools, planing tools, engravers' tools, surgical cutlery, circular metal saws ..	1.2 to 1.3 per cent.
Wood tools, fine saws, large cutting tools ..	1.0 to 1.15 per cent.
Axes, chisels, mining drills .. ..	0.95 to 1.05 per cent.
Needles, screwing dies, taps .. ..	0.90 to 0.95 per cent.
Cutlery, punches, long saws .. ..	0.90 to 0.95 per cent.
Large punches, riveting dies, snaps and boilermakers' tools, hot and cold sets, heading dies .. ..	0.80 to 0.85 per cent.

Dealing first of all with the properties of this second or plain carbon group of tool steels, it is not proposed to enter into any sort of description of the manufacture of tools, nor of the ways in which they should be hardened in actual practice, but merely to indicate the principles underlying the operations, and to give a slight description of the changes produced in the structure of the steels during these processes. When discussing tool steels, there is no point whatever in considering the complete mechanical properties of the steel after the various treatments that might be applied to it, such as must be done effectively for the constructional steels. The only mechanical property of tool steel, in which the engineer can be considered to be interested, is the hardness or cutting property, and this attribute he wants in the maximum degree possible. Along with the hardness, he desires as much toughness as he can get, but is not prepared to sacrifice any large proportion of the hardness for the sake of the toughness. The hardness of a tool steel is by no means an easy thing to measure, principally because nobody knows really what is the nature of hardness (see p. 105). The most satisfactory measure of the hardness of a tool



steel is undoubtedly the use thereof as a tool, and up to the present nothing really practical has been put forward as a substitute for that test. As a consequence, it is of little use to quote elaborate tests showing the complete mechanical properties of tool steels.

The list of compositions of different types of tools given in Table 69, shows that the majority of the tools (and it may be said all the fine tools), have a carbon content of more than 0.9 per cent., and the average content is about 1.10 per cent. It will, consequently, be quite fair, and not at all misleading, to treat all the tool steels as having approximately 1.10 per cent. of carbon. Such a proportion of carbon produces a steel possessing most of the metallurgical properties which have to be considered in connection with the treatment of tool steel. The structure of a steel containing about 1.10 per cent. of carbon, in the normalised condition, can be seen from the photomicrograph in Fig. 96. It is to be noted that the steel contains, round the crystals of pearlite (which can be easily recognised), a network of a white constituent. This is carbide of iron. The network is formed in this position because the carbide is present in the steel in greater quantities than are required for the formation of the pearlite. Just as a normalised steel with less than 0.9 per cent. of carbon has crystal boundaries of free ferrite, i.e., free iron, so the normalised steel with more than 0.9 per cent. of carbon has crystal boundaries of free carbide. On heating such a steel as that shown in Fig. 96 to a temperature slightly higher than its lower critical temperature, and then quenching it out in water, the structure shown in Fig. 97 is obtained. This structure evidently consists of solid solution, with free carbide in a network around the crystals. If the quenching temperature be raised somewhat, the free carbide begins to go into solution, so that a specimen containing 1.10 per cent. of carbon quenched at a temperature of 840° C. will have all its carbide in solution. In the diagram in Fig. 27 in the chapter dealing with Heat Treatment, p. 48, the solution

of the free carbide in the solid solution is indicated by the line CD. By quenching the steel from near to the temperature on the line CD in Fig. 27 that is indicated by its carbon content (this being the true theoretical hardening temperature), the steel, if it is not in a very massive form, will be fixed and retained completely in the "solid solution" condition. For practical reasons (connected with the prevention of cracking in the steel as a result, both of contraction and of the presence in it of a very large proportion of the strong and rigid solid solution), it is usual not to quench tool steel from a temperature quite as high as the theoretical hardening temperature. The most usual temperature to employ is that which is satisfactory for a 0.9 per cent. carbon steel, i.e., about 740° C. to 760° C., so that, after hardening, the steel containing more than this proportion of carbon consists of crystals of perfect solid solution surrounded by a more or less incomplete network, or film, of carbide. Steel possessing such a constitution is very hard indeed. The free carbide is exceedingly hard, while the solid solution is almost as hard as it is possible for any of the solid solutions, produced in commercial steels, to be made.

After the carbon steel tools have been hardened, it is customary to temper them to a small extent, i.e., at a fairly low temperature. As is well known, it has been usual for a great many years to control the tempering operation by making the colour of the oxide film, formed on the surface of the steel during tempering, an indicator of the temperature which has been attained by the tool. The actual range of temperatures covered by the colour indications, and the individual temperatures revealed by each colour in a normal instance, are approximately as shown in Table 70.

All the tempering temperatures are quite low, and their effect upon the hardness of the steel is comparatively slight. It may be assumed that, unless the tempering temperature rises well above 230° C., there is but little decrease in the hardness of the steel. The principal effect

of the tempering is upon the toughness. The increased toughness is not easily shown by physical tests, but the effect of tempering upon the ductility and impact values of 100-ton nickel chromium steels, as shown in the curves in Fig. 63, indicates the kind of alteration in these same properties which takes place in the tool steels when tempered. An additional effect of tempering the hardened tool steels is the removal, in a considerable measure,

TABLE 70.

THE TEMPERATURE INDICATED BY DIFFERENT TEMPERING COLOURS.

Colour of Film.	Tempering Temperature.
Light straw .. .. .	230° C.
Dark straw .. .. .	240° C.
Yellow brown .. .. .	255° C.
Reddish brown .. .. .	265° C.
Purple .. .. .	275° C.
Violet .. .. .	285° C.
Cornflower blue .. .. .	295° C.
Pale blue .. .. .	310° C.
Grey .. .. .	330° C.

of the mechanical strains which are necessarily put into the steel during hardening. These strains have been described in Chapter III, p. 76, and the way in which they are removed by tempering has been indicated in another place. Just the same effect is produced in the tool steels when they are tempered, and it is probable that the tempering operation is quite as valuable by reason of its removal of mechanical strains due to hardening, as for any other reason.

The temperature employed for the tempering of the various tools differs according to the nature of the tool, and the work which it has to do. This means (as is evident from the compositions given in Table 69) that the tempering

temperature is varied according to the composition of the steel. No hard and fast rules can be laid down for the tempering temperature of the different steels used for making tools, as the shape and size of the tool have a decided influence upon the temperatures chosen (or rather upon the colour used, which is the usual way of choosing the temperature). After hardening and tempering, the tools are ready for use, apart from operations such as grinding, etc., which are matters outside the scope of this book.

As is well known to users of carbon steel tools (or those tools which are really carbon steel, although they contain a small proportion—up to 2 per cent.—of alloying elements, such as tungsten or chromium), the durability of such tools is not very great. They cannot be used for machining at high speeds, or with heavy cuts, without becoming softened. The softening is due, of course, to the fact that the tools, when at work, become heated to a comparatively high temperature by the heat produced by the friction inseparable from the work which they are performing. It is quite possible to heat a tool (at any rate on the cutting edge) during machining operations to a very high temperature, e.g., a dull red (about  $600^{\circ}\text{C}.$ ), and this temperature will have a profound influence upon all the mechanical properties of the steel, including the hardness. The effect upon the mechanical properties of high carbon steel of re-heating to high temperatures can be clearly seen from the test figures given in Table 71.

The values shown in Table 71 for the maximum stress of the steels which have been re-heated to high temperatures, show that such steels will not possess the hardness and cutting power required by machining tools. It must also be borne in mind that carbon steel tools do not recover their hardness, after cooling from the high temperatures produced by friction to the normal atmospheric temperature. The only thing to do with carbon steel tools, after they have become soft, is to re-harden them, provided that their dimensions permit of such a treatment. To

find a material which would overcome this defect or weakness of plain carbon steel tools, was the aim of numerous steelmakers and users of tools for many years, but it was not until the employment of alloying elements in steel became fairly common that any good results were achieved. Different alloying elements were added to the steel in very varying proportions, but the one which first gave an indication of producing a steel which possessed the

TABLE 71.

THE MECHANICAL PROPERTIES, AFTER HARDENING AND TEMPERING, OF STEEL CONTAINING

CARBON .. .. . 1.05 per cent.  
MANGANESE .. .. . 0.23 ,,

Heat Treatment.	Yield-point, tons per sq. in.	Max. Stress, tons per sq. in.	Elongation, %.	Reduction of Area, %.
Water-quenched 820° C. .. ..	55.6	104.5	Nil	Nil
Water-quenched 820° C., tempered 550° C. .. .. .	51.6	86.8	6.1	13.6
Water-quenched 820° C., tempered 650° C. .. .. .	45.7	64.7	9.3	33.2

right properties was tungsten. Between the years 1860 and 1900, numerous steels were made containing different proportions of tungsten, and results of varying value were obtained. It was found that the presence of both chromium and tungsten, in the same steel, produced distinctly better results than the presence of either of them singly. The result was the evolution, about the year 1900, of the modern high speed steel. This steel contains only a moderate proportion of carbon—i.e., about 0.6 to 0.7 per cent.—but has a very high proportion of tungsten. The proportion of this element varies, in the latest steels, between approximately 12 and 18 per cent., the majority of the better class of high speed steels containing,

approximately, the higher proportion. In addition to tungsten, the high speed steels contain a notable proportion of chromium, i.e., from 3 to 4.5 per cent. Almost all the high speed steels have the same proportion of chromium. In some of the steels vanadium is present, in a proportion of about 1 or 1.25 per cent. The presence of this element makes no difference to the ordinary fundamental mechanical properties of the steel, but is stated, by the manufacturers of the steels to which it is added, to produce better results, in so far as the cutting powers and durability of the steel are concerned.

The outstanding advantage of high speed steel over plain carbon steel is that, even when heated to a high temperature (comparatively), it does not become unduly softened, and also that, after cooling from this relatively high temperature, the steel completely recovers its original hardness. There is, of course, a limit to the temperature to which the steel can be heated without becoming softened permanently, but this limiting temperature is very much higher than that to which the carbon steels can be heated with safety. It is quite possible to use, with satisfaction, high speed steels which have become heated to a dull red whilst working in a lathe.

The difference in properties between the carbon steels and the high speed steels is not solely due to the differences in composition of the two types of steel. This really means that the two steels, despite the difference in composition, do not display the remarkable difference in properties usually found if both steels are heat treated in the same way. In order to obtain the proper results from the high speed steels, they must be heat treated in quite a different way from that in which the carbon steels are usually treated. The difference in treatment is not merely one of the method of cooling, but of the temperatures employed. In the chapter on Alloy Steels the property of air hardening has been fully and completely described, in so far as it applies to nickel chromium and some other steels. The high speed steels also have air-hardening

properties of much the same kind, as can be seen from the figures given in Table 72, showing the Brinell hardness numbers of high speed steels which have been cooled in air from temperatures between 800° C. and 1,100° C. (It is to be noted that the high speed steel used for the tests quoted in Table 72 was originally in a soft condition, having been first tempered at a temperature near to 800° C. before any tests were made upon it at all.)

TABLE 72.

SHOWING THE BRINELL HARDNESS OF HIGH SPEED STEEL AFTER COOLING IN AIR FROM VARIOUS TEMPERATURES.

Temperature from which the Steel was Cooled, ° C.	Brinell Hardness Number.
650	241
750	248
800	248
850	248
900	376
950	430
1,000	477
1,100	477

The test results given in Table 72 make it clear that high speed steel hardens in air in just the same way as the nickel chromium steels or the high chromium steels of the stainless type. A high speed steel hardened from a temperature of 1,000° C. does not, however, make a good tool, and it would not show the characteristic property of high speed steel, namely, the capacity of resisting the softening effect of re-heating to a low red heat. In order to produce the true "high speed" properties, the steel must be heated to a much higher temperature than 1,000° C., and must undergo a definite change of structure. This change can be appreciated easily from the two photo-micrographs, shown in Figs. 98 and 99, of a high speed steel which has been cooled in air from temperatures

of 1,000° C. and of 1,300° C. respectively. The nature of the constitutional change is rather complex, and even at this date can hardly be said to be completely understood. It is, therefore, not desirable, besides being unnecessary, to enter into any account of it. The characteristic structure associated with the high speed properties, is produced by heating the steel to a temperature between 1,200° C. and 1,300° C., and the constitution produced at this temperature, is retained by cooling the steel at a fairly rapid rate in the air, i.e., by cooling in an air blast. Not infrequently the steel is quenched in oil in order to ensure the necessary rapidity of cooling.

The treatment required for the hardening of high speed steel is practically independent of the composition of the steel, provided that the chromium is over 3 per cent. and the tungsten more than 12 per cent. With a suitable carbon content, i.e., 0.6 to 0.7 per cent., variations of chromium and tungsten, within the limits actually found in the ordinary commercial steels, produce no appreciable difference in the structure of the hardened steel. Such variations as do occur are variations of degree, and not of type, and are, therefore, of little interest to the engineer.

After the high speed steels have been hardened, they can be heated to a comparatively high temperature without suffering any permanent loss of hardness. It is necessary, however, for some of the operations connected with the production of tools from these steels, that they be softened. This change can be effected by a process which is normally termed annealing, but which really is a tempering operation. This fact can be verified by comparing the standard definition of annealing, as sanctioned by the British Engineering Standards Association and given on p. 39, with the temperatures used for hardening high speed steel, and those employed for the so-called "annealing" of the steel. The softening, tempering, or so-called annealing of the steel, is effected by re-heating the steel to a temperature of about 800° C., and allowing



it to cool from this temperature either in air or in the furnace. Some makers prefer to retain the steel at 800° C. for a very long time, and to cool it very slowly, i.e., in the furnace, while others merely heat the steel to the required temperature for an hour or so, and then allow it to cool in the air. The changes in hardness (as indicated by the Brinell test) produced by these treatments, are shown by the test results given in Table 73.

TABLE 73.

THE EFFECT OF RE-HEATING TO VARIOUS TEMPERATURES UPON  
THE BRINELL HARDNESS OF HIGH SPEED STEELS.

Heat Treatment.	Brinell Hardness after Cooling in	
	Air.	Furnacc.
Air cooled from 1,100° C. . . . .	555	—
Air cooled from 1,100° C., tempered 500° C.	512	—
Air cooled from 1,100° C., tempered 600° C.	477	—
Air cooled from 1,100° C., tempered 700° C.	286	—
Air cooled from 1,100° C., tempered 750° C.	277	269
Air cooled from 1,100° C., tempered 800° C.	269	248
Air cooled from 1,100° C., tempered 850° C.	444	207
Air cooled from 1,100° C., tempered 900° C.	495	—
Air cooled from 1,100° C., tempered 950° C.	—	235

The softening process must necessarily be applied to the high speed steels at various stages of their manufacture. When they cool down after casting they are quite hard, and after they have been forged they are hard. In both cases, it is necessary, for the sake of the subsequent operations, to soften the steels. The process of tempering at 800° C. provides the necessary softening treatment. For various reasons this process can be achieved more effectively if the steel, prior to heating at 800° C., is refined. The refining is effected by heating the steel to a temperature of about 950° C., and allowing it to cool in air. This

process hardens the steel (though it does not harden it in the sense that the steel is hardened for cutting purposes), as can be seen from the figures given in Table 72, and the steel softens and tempers much more readily when it has been treated in this way than when the treatment is omitted.

## APPENDIX A

### THE INFLUENCE OF SHARP CORNERS AND SCRATCHES

IN many places in the chapters of this book, reference has been made to the fact that the presence of a sudden change of section, a sharp corner, a tool mark, etc., in the surface of a part, produces, in the steel immediately surrounding, a considerable local increase of stress. The statement is also made, that this local increase of stress can be reduced to harmless proportions by making the radius of the corner sufficiently large, or the change of section sufficiently gradual. As these statements and references have been rather vague, it may be desirable to provide some more precise information regarding the mechanical effect of scratches and sharp corners. It has been known for a long time that the strength of a part is affected by its shape, i.e., by the extent to which the corners and fillets are rounded off, but actual measurements of this increase of stress had not been made extensively until Professor Coker developed his method of making a model of the part in glass or celluloid, and observing the stress distribution produced in it under varying conditions, by an examination of the interference figures produced when polarised light was passed through the model. By this device definite measurements could be made as to the stress produced in different portions of the part, e.g., the stress produced round a hole punched in a plate. Another elegant mode of examination was that developed by Messrs. Taylor & Griffiths, who employed the distortion of a soap film, which normally possessed the shape of a plane section of the part under investigation. By distorting this film (by inflation), the angle of inclination of the film to the normal at different positions could be observed and measured. The shape which the soap film takes when deformed, bears a definite

relationship to the stresses produced in a body of similar cross-section when stressed in torsion, the variations in contour of the film corresponding to abnormal stress distribution in the steel. Griffiths has been able also to extend mathematically the results he has obtained experimentally, and to provide a great deal of information regarding the concentration of stress at different points of sections of varying shape. The soap film method has made it possible to examine the effect of notches and scratches, and particularly to investigate the effect of differences in their contour. The mathematical investigation has been pursued also to deal with the effects of scratches, etc., when the stresses are other than the plain torsional ones whose behaviour can be observed in the actual experiments. The effect of scratches, etc., has been investigated mathematically by Inglis and others.

All the results, both experimental and deduced, go to confirm the particular danger of sharp corners. The accumulation of stress at a plain corner which is perfectly sharp is infinitely great. Such a corner is never met with in practice, though the bottom of a fatigue crack in steel approaches it very nearly (see below). As the radius of the corner is increased, the concentration of stress resulting from the change of section is lowered. As a typical case, that of a keyway in a propeller shaft or back axle may be considered. The stress in the steel at the corner at the bottom of the keyway can be brought down to only 1.5 times that in the normal shaft by inserting a radius at the corner equal to one-fifth of the depth of the keyway. If the radius at the corner is only one-tenth of the depth, the stress in the steel at this point becomes as high as 2.32 times the stress in the normal shaft. (These figures are for torsional stresses.) Scratches or notches present somewhat different figures. It has been shown that the degree to which scratches affect the stress distribution is a function of their depth and the radius at the bottom. The effect also depends upon the angle of inclination of the sides of the notch. The direction of the scratch, in relation to the direction of application of the stress, also affects the degree to which the stresses are concentrated. The nature of the stress applied to the part has also an effect upon the extent to which the stresses are increased. If  $a$  is the depth of the notch, and  $r$  is the radius at its root, then the ratio of the stress in the steel

at the sides of the notch to that in the parts away from the notch is

$$1 + \sqrt{\frac{a}{r}} : 1$$

when the stress is torsional. The orientation of the scratch with respect to the stress, i.e., the angle which the scratch makes with the direction of the applied stresses, does not affect the magnitude of the increase of stress in parts which are stressed in torsion. If the part is stressed in tension, the increase of stress is more than when the part is stressed in torsion, the ratio of the increase to the normal parts being

$$1 + 2\sqrt{\frac{a}{r}} : 1$$

Parts stressed in tension are affected by the direction of the scratch in relation to the stress. If the notch makes an angle  $(\pi/2 - \theta)$  with the direction of the stress, then the stress is increased in the ratio

$$1 + 2 \cos^2 \theta \sqrt{\frac{a}{r}} : 1$$

so that for a scratch parallel to the direction of stress the increase of stress is nil.

A particularly sharp kind of notch is that formed by cracks produced during heat treatment, and otherwise, which occur in steel parts. The radius at the root of such a crack may be, and usually is, exceedingly small (see Fig. 100, showing a photo-micrograph of one such crack). As a result, the steel at the root of the crack is stressed to a very high value, and consequently the crack easily spreads.

In Fig. 101 is shown a photograph of a castellated shaft, in which the radius at the root of the splines was so sharp as to produce a dangerously sharp corner. At each of these sharp corners the stresses were concentrated to such a value as to produce a crack, which can be seen growing inwards from the corners. In actual practice, these cracks grew sufficiently for the shaft to be completely fractured. In Fig. 102 is shown a photograph of a crack which grew in a part simply as a consequence of the stresses produced during quenching, and

concentrated at the comparatively sharp corner produced by the base of a forging lap.

Mention has been made previously, but the statement will easily bear repetition, that in a part stressed steadily in one direction, e.g., a continuous tensile stress, the effect of the sharp corner may be avoided, or neutralised, by the local, incomplete, failure of the steel at that sharp corner. If the stress is sufficiently concentrated in the steel, by the presence of a small radius at a change of section, it may rise to a value higher than the yield-point of the steel. If this occurs, then the steel at the small radius will commence to flow, and will probably distort in such a way that the radius, at the point which is stressed to the greatest value, is increased. The stress is therefore automatically reduced, and the complete failure, i.e., the fracture, of the steel is avoided. In order that this neutralising readjustment shall take place properly, the steel must possess a fair value of elongation and reduction of area, i.e., ductility, so that it may flow sufficiently to take up its new form with comparative ease.

If the stress upon the part is not always applied in the same direction, e.g., always in tension, but is alternating or fluctuating in direction or magnitude, the adjustment by distortion or plastic flow will not occur.

## APPENDIX B

### YOUNG'S MODULUS OF ELASTICITY

It is often stated that the only properties of steel which are of real importance to the engineer designer are the elastic limit and the modulus of elasticity. How true this may be the author is not prepared to say, but whether or not the statement is completely accurate, it is a fact that the modulus of elasticity, "E," is of great importance. It is generally assumed that "E" is a constant for all kinds of steel, and that its value is round about 12,800 in ton-inch units. It seems difficult to believe that "E" really is quite constant for all kinds of steel, when the variations in structure, constitution, and composition are taken into account. It seems very much more probable that "E" varies somewhat in value, but that its variations are not very great. The accurate determination of "E" is by no means easy. It involves the very precise measurement of small lengths, and quite small errors in the measurements may lead to very considerable errors in the values obtained for the modulus. Some very accurate and careful experiments in connection with the value of "E," have recently been made upon steel strip which is likely to have been in the most satisfactory condition as regards homogeneity. This strip had been cold rolled and afterwards blued at various temperatures. The results were very carefully verified, and it was found that the value of "E" in these specimens was by no means constant. Furthermore, it was found that the variations were in no way arbitrary, but that the value of "E" bore a distinct relationship to the temperature at which the steel had been blued. In these tests the value of "E" varied from 11,500 to 13,900 in ton-inch units, the maximum variation being, therefore, about 20 per cent. of the average value. A number of other tests upon steel strip, some of it hardened

by quenching, and tempered, some of it hardened by cold work, and blued, gave maximum and minimum values of "E" of 13,800 and 11,700. In view of these tests it may be considered that it is at least probable that the modulus of elasticity of steel is not quite constant, and that a fair statement of its value would be 12,800 plus and minus 1,000 in ton-inch units.

For certain parts of engines, particularly the springs of petrol engines, the value of "E" at temperatures other than atmospheric is of importance. The determination of "E" at elevated temperatures has not been investigated at all thoroughly. Some experiments by Lea at temperatures up to 500° C. have been made with interesting results. A résumé of these results is given in Table 74.

TABLE 74.

THE EFFECT OF TEMPERATURE UPON YOUNG'S  
MODULUS OF STEEL.

Temperature of Steel.	Modulus of Elasticity of Mild Steel, tons per sq. inch.
300° C.	10,000
400° C.	8,500
500° C.	4,000



## APPENDIX C

### THE PROPERTIES OF STEELS AT HIGH TEMPERATURES

THE development of internal combustion engines has led to the subjection of steel parts, working in mechanical constructions of certain types, to temperatures very decidedly above the normal. Probably the valves in a petrol engine of high brake-horse-power and mean effective pressure, particularly if the

TABLE 75.

THE CHEMICAL COMPOSITION OF THE STEELS WHOSE TEST RESULTS ARE QUOTED IN TABLES 76, 77, AND 78.

Steel.	Carbon, %.	Manganese, %.	Nickel, %.	Chromium, %.	Tungsten, %.
1	0.30	0.46	—	—	—
2	0.71	0.05	—	3.86	17.30
3	0.45	0.08	—	3.75	15.73
4	0.67	0.09	—	3.70	13.56
5	0.45	0.07	—	3.62	13.08
6	0.36	—	0.23	11.2	—
7	1.08	—	0.50	13.1	—
8	0.54	—	0.43	6.3	—
9	1.09	—	0.42	6.3	—
10	0.29	0.43	3.22	0.08	—
11	0.60	0.95	1.99	0.35	—
12	0.35	0.43	—	2.75	—
13	0.67	0.51	—	3.13	—
14	0.29	0.46	3.90	1.14	—

engine is air cooled, are heated to as high a temperature as any steel part in an engine ever reaches, during the performance of its normal duty. It is desirable, therefore, to ascertain what are the properties of the various steels at high temperatures. For this purpose a very large number of tests have been made, at temperatures between 600° C. and 1,000° C., upon

steels of almost all the compositions likely to be used or tried in valves. The tests included tensile, notched bar, and Brinell tests, and some of the results obtained are given in Tables 75 to 78.<sup>1</sup>

TABLE 76.

THE MAXIMUM STRESS IN TONS PER SQUARE INCH OF DIFFERENT STEELS AT HIGH TEMPERATURES.

Steel Number	Steel Description.	Temperature of Specimen, ° C.				
		700.	800.	850.	900.	950.
1	Plain carbon	6.15	—	—	3.7	—
2	High tungsten, high carbon	17.7	10.3	11.1	8.8	6.6
3	High tungsten, low carbon	15.5	—	—	6.3	—
4	Low tungsten, high carbon	15.9	—	—	7.6	—
5	Low tungsten, low carbon	14.7	7.1	9.6	7.4	—
6	High chromium, low carbon	12.1	6.6	—	4.8	4.0 <sup>2</sup>
7	High chromium, high carbon	15.1	8.5	9.6	7.5	6.5
8	Low chromium, low carbon	17.0	—	—	7.05	—
9	Low chromium, high carbon	18.5	—	—	7.5	—
10	3 % nickel, low carbon	9.4	—	—	3.9	—
11	3 % nickel, high carbon	11.5	—	—	4.5	—
12	3 % chromium, low carbon	8.5	—	—	4.2	—
13	3 % chromium, high carbon	11.7	—	—	4.9	—
14	Nickel chromium	10.5	7.0	5.4	4.5	3.5

TABLE 77.

THE BRINELL HARDNESS NUMBERS (DETERMINED BY PROFESSOR EDWARDS' IMPACT BRINELL METHOD) OF TUNGSTEN STEELS AT HIGH TEMPERATURES.

Steel Number.	Brinell Number of Steel at Temperature ° C.						
	200.	400.	600.	700.	750.	800.	850.
2	193	170	149	131	129	119	101
3	200	149	121	110	107	98	92
4	219	166	162	158	143	118	109
5	207	164	129	123	115	109	95

<sup>1</sup> For a complete account of the experiments see Aitchison, *Journ. Inst. Automobile Engineers*, 1919.

<sup>2</sup> Temperature of this specimen 975 ° C.

TABLE 78.

NOTCHED BAR VALUE IN KILOGRAMMETRES OF DIFFERENT  
STEELS AT HIGH TEMPERATURES.

Temperature of Specimen, ° C.					
15.	100.	200.	300.	400.	500.
0.91	1.95	3.60	3.0	3.20	3.00
1.16	2.0	2.95	2.80	3.20	2.95
1.42	4.3	6.0	9.0	9.3	8.0
3.1	7.4	8.1	9.1	8.7	8.2
6.8	6.92	6.92	7.50	8.43	7.40
1.12	1.43	2.76	2.45	3.04	2.81

Temperature of Specimen, ° C.					
600.	700.	750.	800.	850.	900.
3.09	2.67	—	3.62	—	3.92
3.4	3.3	—	4.2	—	7.5
7.5	8.0	—	9.2	—	9.5
8.9	8.8	—	16.0	—	15.8
6.92	6.56	7.28	8.68	9.11	14.00
3.33	2.85	3.19	3.46	4.02	5.25

## APPENDIX D

### PROFESSOR ROBERTSON'S AXIAL LOADING SHACKLES

IN ordinary commercial tension testing it is always assumed that the stress produced is uniformly distributed across the section, i.e., that the load is applied in the longitudinal axis through the centre of gravity of the specimen. This cannot be quite true with the methods usually adopted of holding the specimens. Wedge grips cannot possibly give a uniform distribution with ductile materials. When collar ends are used, the holders usually rest in spherical seatings, which are, however, necessarily so large that the possible friction moment is a large one. The defects of ordinary grips are much more obvious with short small specimens, and with brittle materials. Considerable trouble has frequently arisen from the utterly false character of the tension results when dealing with hard materials. In general, it may be said that with ordinary grips the value of the elastic limit, yield-point, and modulus of elasticity tend to be low for all ductile materials, and for brittle materials the maximum stress may also be considerably below the real value.

A type of shackle which has been very successfully developed by Professor Robertson to overcome these defects is shown in Fig. 103. The holder, into which the specimens are screwed, has a steel ball, which is accurately centred in the centre line of the tapped hole into which the specimens are screwed. This ball rests on a piece of hardened steel fixed on a bar which is attached to the ordinary shackle of the machine. The essential point in construction is that the hole which is to take the ball holder should be machined at the same setting, and concentric with the hole which is to take the specimen.

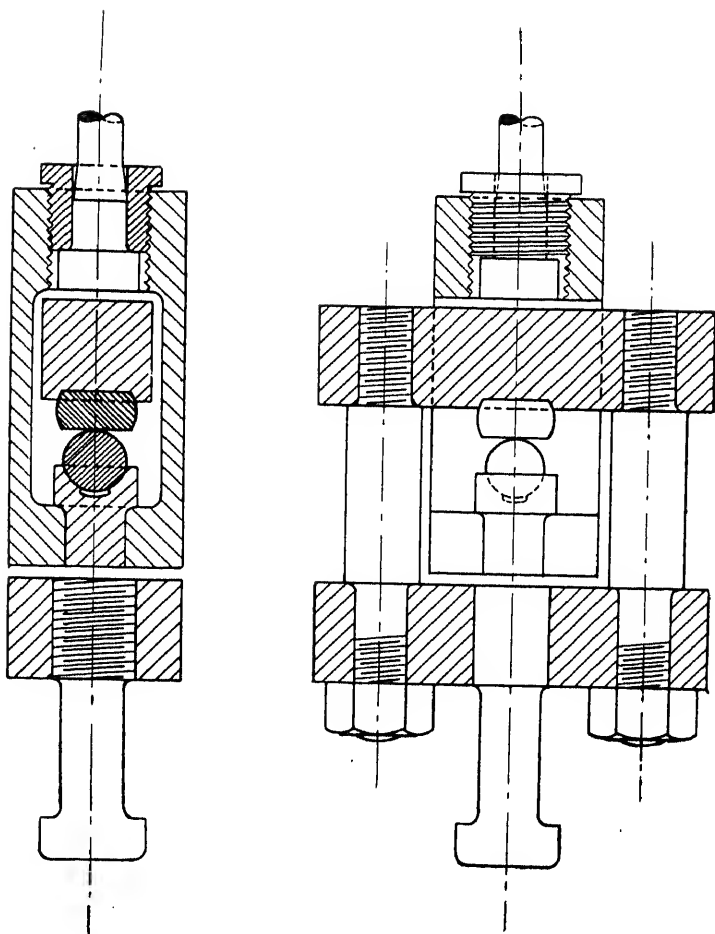

FIG. 103.—FRONT AND SIDE ELEVATIONS OF PROFESSOR ROBERTSON'S AXIAL LOADING SHACKLES.

## AVERY "IZOD" IMPACT TESTING MACHINE

THE machine consists of a heavy base, on to which are bolted two standards which support the fulcrum of a heavy pendulum. The base also contains the vice, which holds the specimen which is to be tested (Fig. 104).

The pendulum, which weighs 60 pounds, swings on ball bearings, and develops a kinetic energy of 120 ft.-lb., since it falls vertically through 2 feet. The specimen is gripped, in the fashion of a cantilever, in a vice let into the base plate. The vice is secured and tightened by means of a hand lever. When fixed in position the root of the notch of the specimen is level with the top of the vice. The notch faces the pendulum before the blow. In order to ensure that exactly the same energy shall be developed by the pendulum in its downward motion every time that a specimen is broken, it is held in its initial position by a locking device which is attached to one of the standards. The pendulum, therefore, always commences its fall from a definitely fixed height relative to the test piece. On releasing the locking device, the pendulum swings and breaks the test piece, the striking point of the head of the pendulum being a hardened steel knife edge. After breaking the test piece, the pendulum continues to swing through an arc, which is greater or smaller according to the energy absorbed by the fracture of the specimen, and in doing so moves an idle pointer over a scale graduated to indicate directly the energy in ft.-lb. required to fracture the test piece.

To check the accuracy of the machine it is necessary to ascertain that the pendulum weighs 60 lb. and falls through a vertical height of 2 feet. It is essential that the knife edge of the pendulum strikes the test piece at the correct distance above the top of the vice (i.e., 22 mm. when the standard specimen shown in Fig. 42 is employed). It is also essential that the suspension of the pendulum shall be as frictionless as it can be made, so that no unduly large proportion of the energy of the blow is utilised in overcoming friction in the bearings.

## APPENDIX F

### CHARPY PENDULUM IMPACT TESTING MACHINE

THERE are two types of this machine, the larger having a power of 250 or 300 kilogrammetres and being electrically controlled, the smaller having a power of 30 kilogrammetres and being operated by hand. The latter type is illustrated in Fig. 45.

As the general principles of both types are the same, a description of the smaller machine will suffice to illustrate them.

The Charpy hand-operated machine consists of a rigid base and two vertical brackets cast in one piece. The brackets support a pendulum at their upper ends, which rotates freely about a horizontal shaft mounted in ball bearings. The pendulum can be raised to a known height, and retained there by means of a trigger mechanism. The test piece, suitably notched (see Fig. 43, which gives the principal dimensions of a Mesnager test piece), is so placed upon rigid horizontal supports that the notch is midway between them, and facing directly away from the pendulum knife edge. These supports are so arranged that when the pendulum is in its free position of repose, the knife edge (which is practically situated at the centre of gravity of the moving part) is just in contact with the test piece, and the notch of the latter is directly in the line of swing of the pendulum. A suitable gauge is provided, by means of which the above positions can be verified.

In order to carry out the test the trigger is released, and the pendulum, after breaking the specimen, rises to a certain height, depending upon the amount of energy required to fracture the specimen. In rising, the pendulum carries an idle pointer over the graduated scale. A hand-operated brake is situated in the base of the machine, which can be used to stop the oscillations of the pendulum.

This machine can also be used for carrying out tensile tests by screwing the test piece into the body of the pendulum. The test pieces are fitted with a cross-bar, which strikes two stops (attached to the frame of the machine) when the pendulum is at the lowest point of its path.

The energy required to fracture a grooved impact test piece can be obtained as follows :

Let  $P$  be the weight of the pendulum,  
 $d$  the length of the pendulum to the centre of gravity,  
 $\delta$  the angle of descent,  
 $\gamma$  the angle of ascent.

Then the energy available at the moment of impact

$$= Pd(1 - \cos \delta) = a$$

Similarly, the energy available immediately after impact

$$= Pd(1 - \cos \gamma) = \beta.$$

Hence the energy absorbed by the fracture of the test piece

$$= a - \beta - (a + f)$$

where  $a$  = the energy absorbed by the acceleration of the broken test piece,

$f$  = the energy absorbed by friction.

It is admitted that the fragments of the test piece assume the same velocity as the pendulum striker edge immediately after impact. Let this velocity be  $V$ , and the weight of the test piece be  $p$ . Then the energy absorbed by the acceleration

of the test piece =  $\frac{1}{2}p\frac{V^2}{g}$

$$[\text{but } V^2 = 2gh \text{ where } h = d(1 - \cos \gamma)]$$

$$\text{and therefore } f = pd(1 - \cos \gamma)$$

In order to determine the amount of energy absorbed by mechanical friction and air resistance, first release the trigger, and note the angle reached by the pendulum after one complete oscillation.

Let  $A$  and  $B$  be the angles before and after one complete oscillation. Then the work absorbed by friction in one oscillation

$$= Pd(\cos B - \cos A),$$



and hence the work absorbed by the downward swing of the pendulum, i.e., through an angle  $\delta$

$$= Pd \left( \frac{\cos B - \cos A}{4} \right)$$

which is constant as long as the angle  $\delta$  is kept constant. Now the angle of ascent  $\gamma$  varies with different test pieces. Hence a series of values for the work absorbed by friction on the upward swing must be obtained. This is effected by allowing the pendulum to swing freely, and noting the angle of ascent at each complete oscillation, until the pendulum comes to rest.

Let  $A_1$  and  $B_1$  be any two consecutive angles of ascent. Then, as above, the work absorbed by friction on the upward swing of the pendulum

$$= Pd \left( \frac{\cos B_1 - \cos A_1}{4} \right)$$

Then the energy absorbed by the fracture of the test piece

$$\begin{aligned} &= Pd(1 - \cos \delta) - Pd(1 - \cos \gamma) - Pd \left( \frac{\cos B - \cos A}{4} \right) \\ &\quad - Pd \left( \frac{\cos B_1 - \cos A_1}{4} \right) - pd(1 - \cos \gamma) \end{aligned}$$

For calculating the shock tensile test, the method is identical with that shown above, with the exception that the weight  $P$  of the pendulum is augmented by the weight of the test piece and cross-bar before fracture, and by half the weight of the test piece after fracture, and that there is no acceleration of the fractured test piece.

## APPENDIX G

### STANTON REPEATED-BLOW IMPACT TESTING MACHINE

IN this machine a suitable specimen is placed on knife edges,  $4\frac{1}{2}$  inches apart, and subjected to blows from a falling tup until it breaks. The rate of stressing is approximately 100 blows per minute. The specimen is 0.50 inch in diameter, and round the middle of its length a V-notch, 0.05 inch deep, is cut circumferentially. The specimen is rotated through an angle of  $180^\circ$  between each blow by means of a suitable link motion. The height through which the striking tup falls can be varied, and may be anything from 0 to  $3\frac{1}{2}$  inches. The tup is actuated by a suitably designed cam, which completes two revolutions to every one of the crank which produces the link motion.

The number of blows struck is registered by a counter, and when the specimen breaks, the tup strikes a small bell crank lever which breaks the circuit of the driving motor, and thus stops the machine.

Dr. Stanton points out that the machine may be used satisfactorily in one of two ways. Since the height of fall of the tup may be altered considerably, the number of blows required to produce fracture is exceedingly variable. The two proper ways of using the machine, as shown by Dr. Stanton, are: (1) when the height of fall is very large, and when, therefore, the number of blows required to break the piece is very small; and (2) when the height of fall is very small, and when, therefore, the number of blows delivered is very great. Under the former conditions, the number of blows for fracture being less than 500, the results obtained are stated to approximate to those of a single-blow impact test. Under the latter conditions, the number of blows for fracture being greater than 100,000, the results obtained are in the order of the fatigue

ranges of the materials as determined in a Wöhler fatigue test. It is practically impossible to interpret the results obtained in those tests, so frequently made during the war, in which the height of fall of the hammer was such that fracture was produced after about 4,000 to 6,000 blows. Such conditions should, therefore, not be employed, as the machine was never intended to be used in that way.

The Cambridge and Paul Instrument Company have brought out a modified and improved form of the above machine, of which the following is a detailed description :

“The general appearance of the machine is shown in Fig. 105, and Fig. 106 is a diagrammatic sketch of the hammer and lifting gear. Referring to these figures, the machine is fitted with a cone-pulley A, so that it can be driven by a belt from a line shaft or small electric motor. One end of the spindle driven by this cone-pulley carries a crank B, which is connected to the lifting rod C. This lifting rod is supported on a roller D, at some point in its length, so that the circular motion imparted to the rod at the crank end causes it to rock and slide on the roller. Thus an oval path, shown dotted in Fig. 106, is traced by the free end of the lifting rod. At this end the rod is bent at right angles, so that on the up-stroke it engages with and lifts up the hammer head E. This hammer head is fixed to the rod F, which is hinged at the end G. Having reached the top of its path; the lifting rod C moves forward, disengages with the hammer, which then falls freely on to the specimen H under test.

“This cycle is repeated from 70 to 100 times a minute. The height through which the hammer falls can be varied by moving the roller D along a scale M, which is calibrated to read directly the vertical height through which the hammer falls. Adjustment can be made by this means up to a maximum of  $3\frac{1}{2}$  inches (90 mm.).

“The specimen H is usually about  $\frac{1}{2}$  inch (12 mm.) in diameter, with a groove about 0.05 inch deep turned in it at its centre to ensure its fracture at this point in its length. It is supported on knife edges  $4\frac{1}{2}$  inches (114 mm.) apart, the hammer striking it midway between these knife edges. The knife edges are cut slightly hollow, and a finger spring K holds one end of the specimen in place. The other end is held in a chuck,

which is hinged in such a manner that it does not take any portion of the hammer blow, all of which comes on the knife edges.

“The specimen remains stationary whilst the blow is struck,

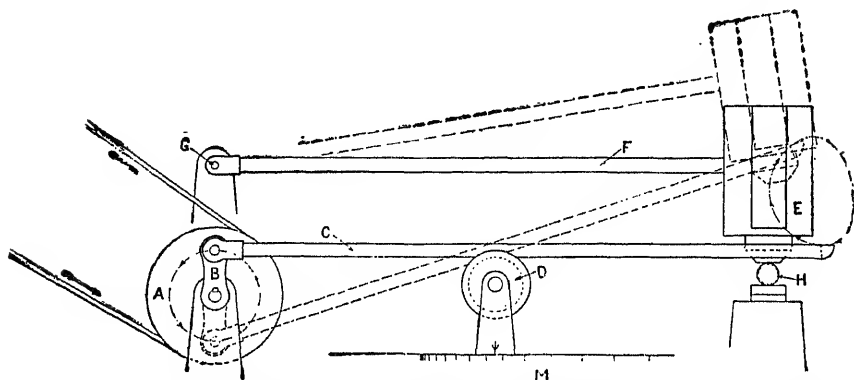

FIG 106.—DIAGRAMMATIC ILLUSTRATION OF THE HAMMER AND LIFTING GEAR OF THE STANTON REPEATED IMPACT TESTING MACHINE.

but between the blows it is turned through an angle of  $180^\circ$ . The mechanism for turning the specimen through this angle is shown in Fig. 107. The wheel J is rotated uniformly by means of a chain drive, making one complete revolution for

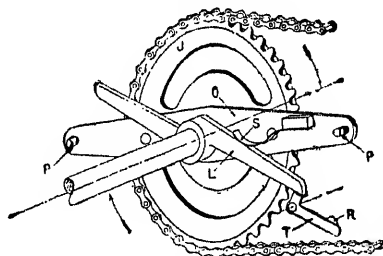

FIG. 107.—DIAGRAMMATIC ILLUSTRATION OF TURNING MECHANISM OF STANTON MACHINE.

every two blows of the hammer. This wheel is connected through a spring S to the chuck holding the specimen, and, whilst the hammer is making the stroke, this spring is being compressed, the specimen being prevented from rotating by

As of the lever L, which is held in contact with the stop T. When the blow is struck, the arm O, travelling round with the lever J, releases the stop T by one of the pins P, which engages the projection R of the stop.

A revolution counter to register the number of blows struck is attached to the bed plate of the instrument. When fracture occurs the specimen falls away, and the hammer head continues to revolve, first tripping an electric switch, and finally coming to rest on a steel stop-pin H. The electric switch should be connected in the driving motor circuit, so that immediately after tripping the motor will stop."

## APPENDIX H

### HAIGH ALTERNATING-STRESS TESTING MACHINE

IN fatigue-testing machines, several important advantages are gained by stressing the steel alternately in tension and compression, instead of stressing by bending. These advantages are: (1) That since the whole cross-section of the test piece and a considerable length is subjected to the full range of stress, a larger volume of metal is tested. The result gives, therefore, a more reliable indication of the fatigue limit; (2) That the result is not quite so dependent upon the rough or smooth finish of the specimen; (3) That since the test piece need not have a shoulder to localise the zone of maximum stress, the value of the stress may be deduced with greater accuracy; (4) That the stress cycle may be varied at will, to alternate between equal or unequal intensities of pull and push. On the other hand, there are disadvantages, the main one being the difficulty of designing a testing machine capable of measuring, with accuracy, stresses which are alternating between direct pull and direct push, with such a high frequency of reversal as is essential for rapid testing.

In the electro-magnetic fatigue-testing machine designed by Professor Haigh of Greenwich, the range of stress can be measured with accuracy, although the frequency of reversal is exceedingly rapid. The standard size in which this machine is manufactured gives a range of load (from tension to compression) of  $1\frac{1}{2}$  tons, and the frequency of reversal is usually 2,000 complete cycles per minute.

The sectional drawing in Fig. 108 shows the general arrangement of the machine.

The upper end of the test piece T is screwed into an adjustable head, in which it is rigidly held. The lower end of the test piece is connected with the laminated armature A of an alter-

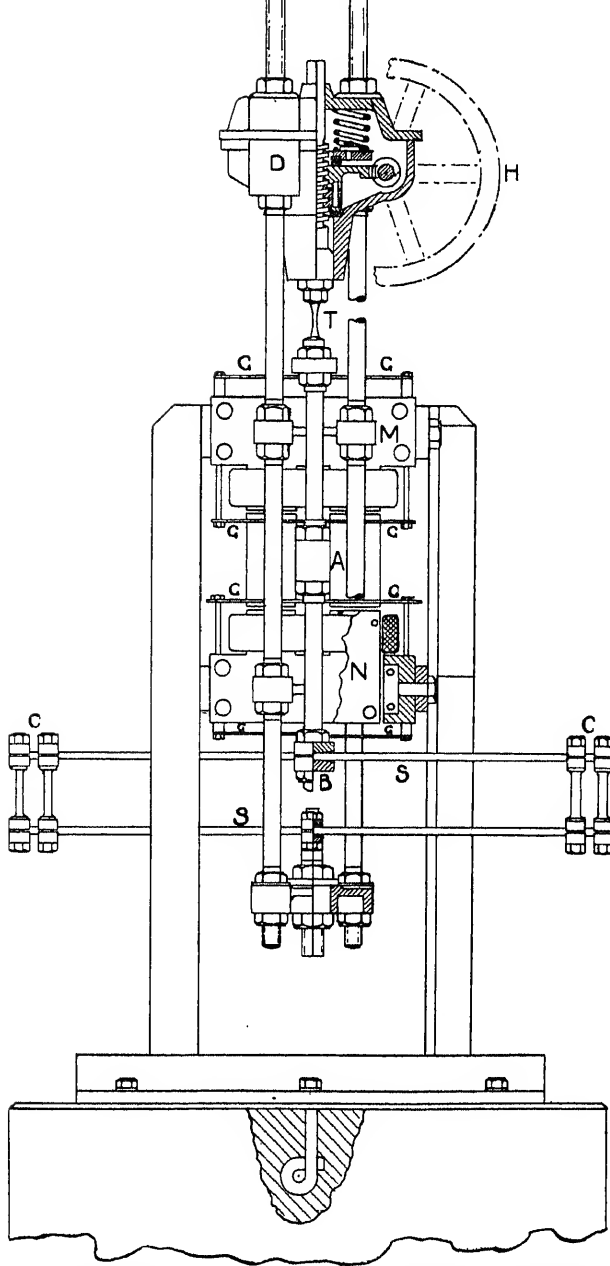

FIG. 108.—SECTIONAL ELEVATION OF HAIGH ALTERNATING-STRESS TESTING MACHINE.

nating electro-magnet. The laminated magnets M and N, of U-shaped profile, are supplied with two-phase current, in "quadrature," by means of a small alternator driven by a motor taking about one-half horse-power, and giving a sine-wave E.M.F. The pull of these magnets attracts the armature alternately upwards and downwards.

It is characteristic of such a system that the magnetic pull produced (which pulsates with double the frequency of the electric current) is proportional to the square of the ratio between the voltage and the frequency, i.e.,

$$F = k \left( \frac{E}{c} \right)^2$$

where F is the force produced, E is the voltage of the magnetic circuit, and c is the frequency of the alternating current supplied. This relationship holds good so long as the leakage flux is a constant proportion of the whole flux. In practice, the leakage flux is proportional to the gap between the armature and magnet, and to the width of the periphery of the vibrator, whilst the useful flux is proportional to the area of the vibrator. It follows, therefore, that it is important to work with an approximately constant gap. A large machine (in which the ratio of the periphery to the area is small) is consequently easier to design than a small one.

A small coil of fine wire is wound on a frame which is fixed close to, and round the edges of, each pole face, and is connected directly to an instrument somewhat similar to a sensitive alternating voltmeter, which acts like the secondary winding of a transformer. Each coil is so introduced that the voltmeter readings, from which the load or stress is deduced, are as free from leakage errors as possible, and the instrument is arranged to give readings which are independent of the variations in the speed of the alternator.

For a given flux density, the magnetising current is directly proportional to the mean length of the air gap. Hence the pulls of the two magnets M and N (in opposite directions) are equal when the air gaps (between the armature A and each pole face) are equal, provided that the leakage flux in each is the same. The armature can be raised or lowered, and hence the gaps adjusted, by turning the hand-wheel H, which raises or lowers the test piece, to the lower end of which the armature



is connected. The adjustment is correct when a differential ammeter connected to both phases reads zero, showing that the currents in the two phases are equal. When this condition exists, the armature is adjusted so as to vibrate midway between the two magnets. The range of variation of load is double the pull of either magnet acting alone, because, the two-phase E.M.F.'s being in quadrature, the pull of one magnet is at its maximum when that of the other is zero, and vice versa.

The scale of the measuring instrument is standardised by comparing its readings with those of a sensitive optical extensometer attached to a standard test piece. The voltage and frequency being measured simultaneously, the calibration constant  $k$  can be determined from the equation given above, namely,

$$F = k \left( \frac{E}{c} \right)^2$$

Since eddy currents in the laminations cannot be avoided, and, as they are proportional to the frequency, and the pull is proportional to the square of the flux, it is necessary to determine the values of the constant  $k$  over a wide range of conditions.

In order to give lateral guidance to the armature, and to keep its faces parallel to those of the pole pieces, light steel springs GG are used in preference to lubricated guides, which might cause a large and variable amount of friction. The tautness of the guide springs also ensures the absence of bending stresses in the specimen.

An important feature of the machine is the means adopted to ensure that the inertia forces, absorbed in accelerating and decelerating the mass of the armature, are not included as a part of the measured stress. If this were not done, a correction of some 5 per cent. would have to be applied when calculating the stress range in the specimen. The armature A is supported on a stiff spring S, located below the lower magnet N, and secured to the frame of the machine. The stiffness of the spring S can be readily adjusted by moving the clamping saddles CC inwards or outwards, so that the moving system (without a test piece in the machine) vibrates in resonance with the magnetic pull, and is approximately equal to the frequency at which the fatigue test is to be performed. The initial tension or compression in the spring S can be so adjusted, by means of the

yoke B, that the test piece is stressed, if so desired, between unequal intensities of pull and push, the magnets still being supplied with equal voltages in quadrature.

The adjusting hand-wheel H actuates a worm-gear and screw in the upper part of the machine, thus raising or lowering the holder which takes the upper end of the test piece T. A double nut, carrying a spring loaded to a greater value than the maximum compressive load on the test piece, is so arranged that the mechanism is free from backlash and chatter, although it is readily adjusted by hand. As the whole of the upper gear D can be raised or lowered relatively to the magnets or armature, test pieces of non-standard dimensions can be employed when so desired. It is also possible to place a small electric furnace

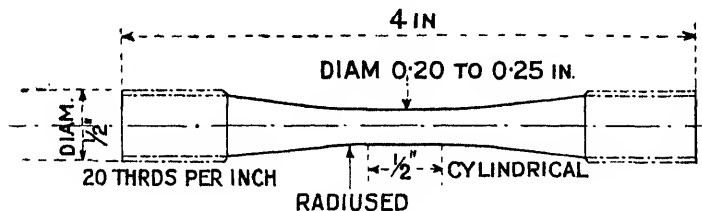

FIG. 109.—TEST PIECE TO BE USED IN HAIGH MACHINE.

around the test piece, while under load, if it is desired to test at elevated temperatures.

As the "circuit of stress" is self-contained within the machine, no appreciable vibration is transmitted to the foundation. When the test piece breaks, the current is automatically switched off by means of a small contact which actuates the "no-voltage" relay of the motor. An automatic counter records the number of cycles endured by each specimen, and the wave form of the magnetic pull is checked by means of a small search coil wound round a pole piece and connected to an oscillograph.

Fig. 109 shows the form of test piece used. The dimensions shown are the minimum sizes, recommended for high tensile steels. The screwed ends run down to the cylindrical mid-portion in a fine taper with smooth transition curves, thus

## APPENDIX I

### BRINELL BALL TEST MACHINE

THIS machine was devised by A. J. Brinell in 1900. The test consists in forcing, by means of a hydraulic press, a hardened steel ball into the surface of the object under test, by means of a fixed load.

Fig. 110 is from a photograph of the normal type of machine in general use.

The whole of the mechanism is held together in a rigid frame. The hydraulic press carries a downwardly acting ram, at the lower end of which is suitably attached a hardened steel ball *k*. A somewhat thick mineral oil is fed into the oil container and press cylinder, through the funnel *t*, which contains a fine sieve for filtering the oil. The pressure is generated by closing the valve *v*, and operating a small hand-pump, the air in the press cylinder escaping through the valve *a*.

The ram works without packing, as the friction caused by such an expedient would impair the efficiency of the machine. Leakage is almost entirely prevented by the accurate fitting of the ram in the press cylinder. The small quantity of fluid which passes through collects in the vessel *d*, and is returned periodically to the press cylinder through the funnel *t*. A pressure gauge is attached for registering the pressure attained, but as it is not possible to rely on the gauge remaining permanently accurate, the machine is provided with a dead weight control, which limits the maximum pressure obtainable to what is required for the test. This control consists of a steel ball which fits closely in the small tube *a*. The ball is held down through the pressure of a small steel rod, having a cup-shaped end, and supporting a cross-bar provided with hangers for weights. The tube *a* communicates with the press cylinder, and when the pressure causes the ball to lift, forms a frictionless

piston with a traverse limited by the length of the tube *a*. The cross-bar is loaded according to the pressure desired, and as long as the piston "floats" (forming a minute hydraulic accumulator), the desired pressure is maintained. The material to be tested is placed on the press table *S*, which is raised, by means of the hand-wheel *r*, until the material comes in contact with the ball *k*, the valve *v* having first been opened to ensure that all pressure is released.

The normal size of ball used is 10 mm. diameter, and pressures can be obtained in intervals of 500 from 500 to 3,000 kilograms.

## APPENDIX J

### DERIHON "HARDNESS TESTING" MACHINE

THE action of the Derihon hardness testing machine is based upon the elasticity of the material of which the frame is constructed. The section shown in Fig. 111 illustrates the general arrangement of the portable type of Derihon machine, and is useful for demonstrating the action of the frame.

The downward movement of the ball plunger is effected by depressing the hand-lever. This lever rotates the smaller gear wheel, which, in turn, rotates a larger gear wheel, to the spindle of which a cam is attached. This cam acts upon a roller carried by the upper end of the ball plunger, which is thereby depressed. The effect of pressing the hardened steel ball upon the test piece is to cause the frame to distort elastically, and to open to an amount which is proportional to the pressure exerted. The frame is never stressed beyond its elastic limit. The pressure thus exerted is registered by means of a needle pointer, attached to the frame, which moves over a suitably graduated scale carried on the outer, non-stressed and, therefore, immovable cover of the machine.

The photograph shown in Fig. 112 illustrates a machine suitable for workshop use, being the one usually employed. This type weighs approximately half a ton as against the 19½ lb. of the portable outfit.

In the larger machine the hand-lever, gear wheels, and cam are done away with, the pressure of the hardened steel ball upon the test piece being obtained by means of a heavy circular weight, seen in the rear of the machine near the base. This weight is connected to a windlass, by a steel cable which passes over a pulley carried on the lever seen immediately above the weight. The load of the weight is applied to the ball plunger by this lever, by rotating the windlass and so raising the weight.

In order that the load shall be applied evenly and gradually, the whole mass of the weight is supported by a bolt (on which it is pivoted), which rests in the main frame whilst the load is at rest. On rotating the windlass, a gradually increasing proportion of the mass of the weight is transferred from the

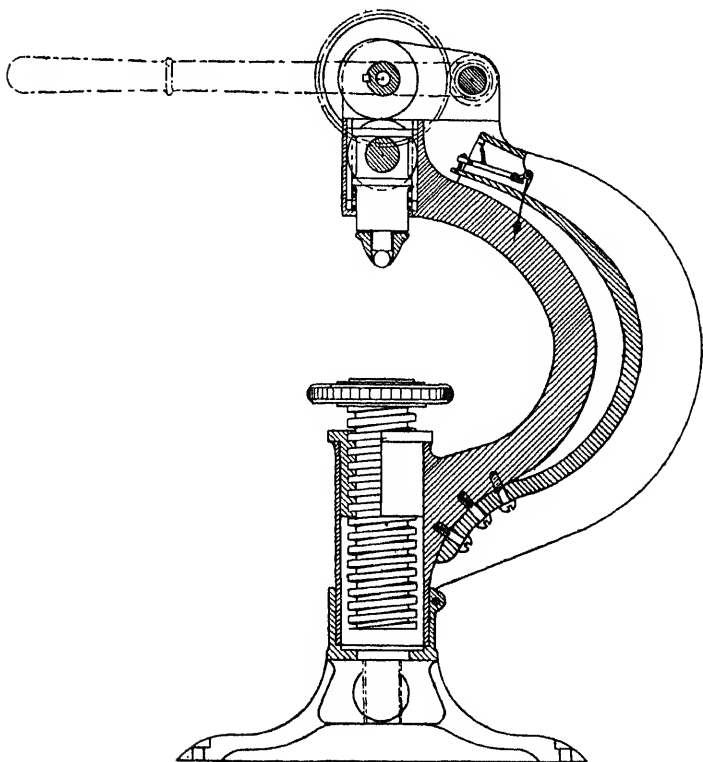

FIG. 111.—DIAGRAMMATIC ILLUSTRATION OF PORTABLE DERIHON "HARDNESS TESTING" MACHINE.

bolt to the wire cable and hence to the lever, until, when the bolt moves upwards in the vertical slot shown in the side of

## APPENDIX K

### JOHNSON BALL-HARDNESS TESTING MACHINE

THE essential difference between this type of ball-hardness testing machine and the original Brinell machine, is in the apparatus devised for applying, and, if necessary, maintaining for any desired length of time, a constant pre-determined pressure upon the specimen to be tested. This is effected as follows :

Figs. 113 and 114 are side elevation and plan, respectively, of the machine. The apparatus is carried in a foundation framework formed upon a bed plate, on which is supported the material to be tested. Above this bed plate is located a screw-threaded spindle E, carrying, at its lower end, a socket in which is fitted the hardened steel ball A. The spindle E is carried by a lever D, by means of a pivotally secured nut, and is cushioned by a spring, arranged between the nut and a tapered washer engaging an aperture in the casing. One end of the lever D is connected with an eccentric strap, co-operating with an eccentric C, mounted in ball bearings, and adapted to be rotated by means of a hand-lever B. Both the lever B and eccentric C are carried upon a shaft. The other end of the lever D is connected with an eccentric strap, co-operating with the eccentric F mounted in ball bearings and carried by a shaft. Upon this shaft is mounted a lever G, the free end of which carries a weight H, the amount of which is proportioned to the leverage, in a manner which is dependent upon the value of the pre-determined maximum pressure to be applied by the hardened steel ball. The material to be tested (which must have a smooth flat surface) is placed on the table I, and the spindle C adjusted until the ball A comes in contact with the smooth flat surface of the specimen.

On rotating the lever B and eccentric C, the hardened steel

ball is forced, under a pre-determined pressure, into the material to be tested, through the medium of the lever D. The load is regulated and applied by means of the eccentric F, together with the attached lever G and weight. Should the pressure tend to rise above the pre-determined value, there would immediately be an upward movement of the lever G. The amount of upward movement may be limited by a suitable stop. In order to ensure that the lever shall not reach the stop, in operation, and thus allow of the application of a pressure greater than the pre-determined maximum, a pawl J is mounted upon the casing, and adapted to co-operate with a toothed sector carried by the hand-lever B. When the lever G rises (on the pre-determined pressure being reached), it allows the pawl to lock the hand-lever against further movement in the direction of applying the load.

In order to enable the pre-determined pressure to be maintained for any length of time, a second pawl L is mounted on the frame of the machine, and is so operated by the stop M that it engages and locks a toothed sector of the hand-lever against rotation in the direction of releasing the load.

For steels and metals of similar hardness, a ball of 10 mm. diameter, and a load of 3,000 kilograms maintained for fifteen seconds are used. For softer metals, the 10 mm. ball is used in conjunction with a load of 500 kilograms maintained for thirty seconds.



## APPENDIX L

### LEE REVERSE TESTING MACHINE

THIS machine is designed to carry out accurate bend tests, on all classes of wire, metal strips and sheet. The machine consists of an oval base plate which can conveniently be fixed to any kind of bench. Mounted on the base plate is a platform, which is rotated around a central pin by means of a handle. The platform carries, immediately over the pivot, a die box, into which dies, with corners of varying radii, can easily be fitted. The other dimensions of the dies are such as allow all of them to fit the same box.

The specimen to be tested is held by a vice at each end, one vice being fixed to the base plate, whilst the other is attached to the rotating platform. The conspicuous advantage of this type of machine is that, in virtue of the test piece being fixed by the two vices, it is bound to follow the profile of the die which carries the corner of the specified radius round which the steel is to be bent, thus avoiding the possibility of the strip kinking over a sharper radius than is intended (see Figs. 115 and 116).

## APPENDIX M

### THE ATCHERLEY BEND TESTING MACHINE

THIS instrument consists of two links, A and A1 (Fig. which are hinged together, by means of two tubular rivets a central hole into which fits the pin F. This pin is separately at H. Into these links are fitted two wedge-shaped levers B and B1, which can be adjusted, in the direction their length, by means of the milled nuts E and E1 en

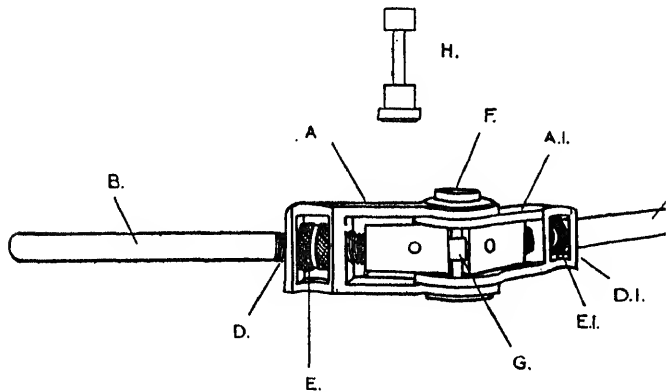

FIG. 117.—ATCHERLEY BEND TESTING MACHINE AND PIN ROUND WHICH STRIP IS BENT.

the threaded portions D and D1. A number of pins are supplied with the machine, the diameters of the central portions varying from 0.08 inch to 0.36 inch. The top and bottom portions of each pin are of such size as to fit easily into the two tubular rivets referred to above.

In order to carry out a test, the two levers B and B1 are rotated as close to each other as they will go, which brings the two wedge-shaped heads close together. The strip G,

material to be tested, is placed between the pin and the heads, the latter being adjusted by means of the milled nuts E and E1, so that they exactly engage the strip without bending it (see Fig. 118). The two levers are then rotated through an angle of approximately 200 degrees, bending the strip round the central pin. This process is repeated, using pins of successively smaller diameters, and similar strips until the strip just cracks.

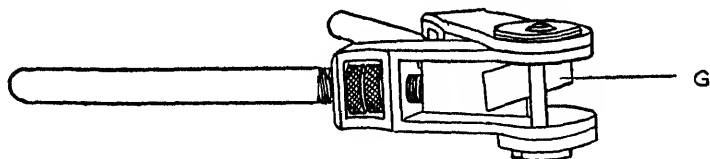

FIG. 118.—GENERAL ARRANGEMENT OF ATCHERLEY BEND TESTING MACHINE, SHOWING INITIAL POSITION OF STRIP

The ductility of the metal is expressed, as the ratio of the radius of the pin at which the strip cracked to the thickness of the strip.

For carrying out a reverse bend test, extra jaws are attached to the wedge-shaped heads (Fig. 119). Jaws having noses of varying radii can be attached to the wedge-shaped head X, which is so adjusted that the nose of the radiused jaw is at

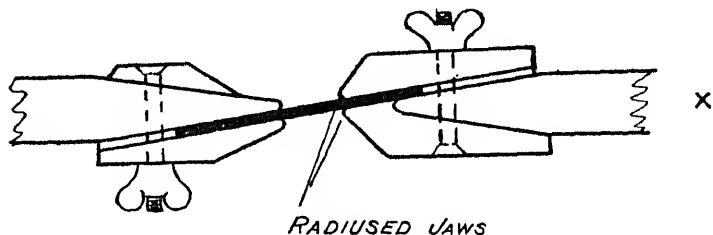

FIG. 119.—JAWS OF ATCHERLEY BEND TESTING MACHINE.

the central point of the axis of rotation. The strip is then fixed in the jaws and the levers bent backwards and forwards, through an arc of 180 degrees, until fracture of the strip occurs, the number of bends endured being regarded as a measure of the ductility of the material. For steel, a radius of from three to five times the thickness of the strip is suitable, according to the tensile strength of the steel.

## APPENDIX N

# BIBLIOGRAPHY OF ORIGINAL PAPERS ON THE HARDNESS OF METALS

### METHODS OF TESTING AND MACHINES.

#### 1. Resistance to Abrasion.

- EXNER. Preisschrift, Wein, 1873.
- BOTTONE. "Rotating Soft Iron Disc." Chem. News, vol. xxvi, 1873, p. 215.
- COHEN. v. Rosenbusch, Mikros. Physiographie, I, p. 258.
- TURNER. "Sclerometer." Proc. Phil. Soc. of Birmingham, vol. v, 1886.
- MARTENS. "Sclerometer." Genie Civil, vol. liv, p. 342.
- BEHRENS. "Grinding with Standard Powder." Anleitung zur Mikrochemische Analyse, 1895.
- ROSIWAL. "Grinding with Standard Powder." Verhandl. k. k. Geol. Reichsanstalt, 1896, vol. xvii, p. 475.
- JAGGAR. "Microsclerometer." Amer. Journ. of Science, 1897, vol. iv, p. 399
- POST. "Wear of Steel Rails." Organ. fur. d. Fortschritte des Eisenbahnwesens, 1899, p. 268.
- KEEP. "Hardness or the Workability of Metals" (Standard Steel Drill). Trans. A.S.M.E., Dec., 1900.
- KIRKALDY. "Effect of Wear upon Steel Rails." Min. Proc. Inst. Civ. Eng., vol. cxxxvi, p. 141.
- KYRNAKOFF and SCHEMTSCHUSCHUY. "Sclerometer." Zeitsch. Anorg. Chem., 1908, sect. 60, p. 1.
- SANTER. "Wear Test." Journ. Iron and Steel Inst., 1908, vol. iii, p. 73.
- MAURER. "Brinell Hardness Numbers in Relation to the Wearing Power of Steel." Metallurgie, 1909, vol. vi,

- SCHL. "Sclerometer." Die. Harte der festen. Korper, Dresden, 1909.
- L. PARSONS. "Sclerometer." Amer. Journ. of Science, vol. xxix, p. 162.
- P. "Sclerometer." Amer. Journ. of Science, vol. xxxi, p. 96.
- ROBIN. "Wear of Steels by Abrasion." Revue de Metallurgie, Jan., 1911.
- NITER. "Hardness Testing and Resistance to Mechanical Wear." Proc. Int. Assc. Test. Mat., New York, Sept., 1912.
- ROBIN. "Abrasion Tests of Steels." Int. Ass. Test. Mat., 1912, sect. 1, 3-6.
- L. HEATHCOTE. "An Improved Sclerometer." Journ. Iron and Steel Inst., 1914, vol. i, p. 363.
- ANTON and BATSON. "Hardness and Wear Tests." Proc. Inst. Mech. Eng., Oct.-Dec., 1916, p. 677.
- C. UNWIN. "Memorandum on Tests of Hardness and Resistance to Wear." *Ibid.* Appendix 1.

## 2. Resistance to Indentation.

### (a) *The Ball Method.*

- ERTZ. Verhandl. Berlin, Phys. Gesells., 1882.
- WAHLBERG. "Brinell Machine." Journ. Iron and Steel Inst., 1901, vol. i, p. 243.
- Journ. Iron and Steel Inst., 1901, vol. ii, p. 234.
- FOPPL. "Self-Indentation." Ann. Phys. Chem., 63 i, p. 103.
- OHNSTEIN. "The Huber Modification of Brinell's Test." Stahl und Eisen i, April, 1904.
- The Guillery Hardness Testing Apparatus." Engineering, Jan. 12, 1906.
- REUSS. "Hydraulic. Ball." Baumaterialenkunde, 1907, p. 295.
- LESEN. "Ball Machine for Testing Locomotive Tyres." Iron Trade Review, vol. xlv, p. 257.
- OHNEIDER. "Falling Weight. Ball." Zeitsch. des Vereines deutscher Ingenieure, vol. liv, p. 1631.
- COLFI. "Portable Ball Machine." Metallurgia Italiana, 1914, p. 199.
- ARTENS. "Hydraulic Ball." Engineer, 1914, vol. cxvii, p. 281.

- TURPIN. "Hand Brinell Machine." *Revue de metallurgie*, Memoires, 1915, vol. xii, p. 104.
- "The Derihon Machine." *Automobile Engineer*, Feb., 1916.
- EDWARDS and WILLIS. "Falling Weight." *Inst. Mech. Eng.*, June, 1918.
- J. G. AYERS. "Impact Brinell." *Proc. Amer. Soc. Test. Mat.*, 1918, vol. xviii, part 2, p. 460.
- "Johnson Hardness Testing Machine. Ball." Pamphlet, Brown, Bayley's Steel Works, Ltd., Sheffield.

(b) *The Cone, Knife-Edge, or Pyramid Methods.*

- WADE. "Pyramidal Point." *Reports on Metal for Cannon*, 1856, Ordnance Dept., U.S.A.
- MIDDLEBERG. "Curved Knife Edge." *Engineering*, 1886, vol. ii, p. 481.
- MARTEL. "Pyramidal Point Falling Weight." *Commission des Methodes d'Essai des Materiaux de Construction*, 1895, vol. iiiA, p. 261.
- CALVERT and JOHNSON. "Truncated Cone." *Phil. Mag.*, vol. xvii, p. 114.
- W. C. UNWIN. "A New Indentation Test for Determining the Hardness of Metals." *Proc. Inst. Civ. Eng.*, vol. cxxix, 1897.
- LUDWIK. "Cone." *Zeitschr. d. Oesterreich. Ingen. u. Architekten Vereins*, vol. lix, pp. 191 and 205.
- GESSNER. "Cone." *Ibid.* p. 799; *Int. Ass. Test. Mat.*, 1901-2-3.
- "The Amsler Hardness Testing Machine and Cone Attachment." *American Machinist*, 1908, vol. xxxiii, No. 15.
- BALLANTINE. "Plunger. Point." *Journ. Franklin Inst.*, vol. clxvi, p. 447; *American Machinist*, 1907, vol. xxx, No. 20.
- WALDO. "Dropping Weight Cone." *Metallurgical and Chemical Engineering*, 1917, vol. vi, No. 2, p. 95.
- ROBIN. "Circular Knife-Edge Cutter." *Societe d'encouragement pour l'Industrie Nationale*, March-April, 1917.

### 3. Scleroscopic.

- SHORE. "The Shore Scleroscope." *American Machinist*, 1907, vol. xxx, part 2, p. 747 or p. 845 (London Ed.); Pamphlet The Coats Machine Tool Co., Caxton House, London, S.W.

KIRNER. "Rebound of Pendulum." American Machinist, vol. xxxiii, p. 972.

#### 4. Electro-Magnetic.

LAKE. American Machinist, vol. xxxi, part 1, p. 557.

HUGHES. "Schuchardt and Schutte Hardness Tester." Iron Age, vol. lxxxi, p. 1162, April 9, 1908.

WILD. Trans. Faraday Society, July 14, 1919.

#### SUMMARY OF COMPARISONS OF VARIOUS HARDNESS TESTING MACHINES.

MEYER. "Results of Hardness Tests by Various Methods." Revue de Metallurgie, 1908, vol. v, p. 329.

TURNER. "Notes on Tests for Hardness." Journ. Iron and Steel Inst., 1909, vol. i, p. 426.

R. P. DEVRIES. "A Comparison of Five Methods of Hardness Measurements." Am. Soc. Test. Inst., 1911, p. 709.

KUHNEL and SCHULZ. "Description of Five Various Hardness Tests." Giesserei Zeitung, 1914, vol. xi, pp. 1, 56, and 89.

W. N. THOMAS. "A Few Experiments on the Hardness Testing of Mild Steel." Journ. Iron and Steel Inst., 1916, vol. i, p. 255.

W. C. UNWIN. "Brinell and Scratch Methods of Hardness." Engineering, 1919, vol. cviii, p. 669.

#### BALL-HARDNESS TESTING.

AUERBACH. "Theoretical Considerations." Wied. Ann. Phys., 1891, (3), 43, p. 60; 1892, (3), 45, pp. 262, 277; 1900, (4), 3, p. 108.

F. OSMOND. "The Static Penetration Method." Report, Commission des Methodes d'essai, Paris, 1893.

H. LE CHATELIER. "Relation Between Brinell Hardness Numbers and Mechanical Properties of Steel." Revue de metallurgie, 1906, vol. iii, p. 689.

MEYER. "Mathematical Considerations." Physikalische Zeitschrift, 1908, p. 66.

L. REVILLON. "Application of the Brinell Test to Specially Small Pieces of Steel." Revue de metallurgie, May, 1908.

H. MOORE. "Investigations on the Brinell Method of Determining Hardness." Proc. Int. Assoc. Test. Mat., 1909.

- A. MARTENS and E. HEYN. "Simplified Ball-Hardness Testing Machines." *Int. Assoc. Test. Mat.*, 1909, 2-2.
- GRARD. "Relation of Brinell Hardness Numbers to Tensile Tests." *Int. Assoc. Test. Mat.*, New York, Sept., 1912.
- HENRIOT. "Effect of Varying Sizes of Ball and Effect of Cold Work on Hardness." *Comptes Rendus*, 1912, vol. clv, pp. 713 and 1502.
- RICOLFI. "Brinell Hardness in Relation to Manufacture and Treatment of Projectiles." *Metallurgia Italiana*, Dec. 16, vol. viii, p. 690.
- BATSON. "Value of the Indentation Method in the Determination of Hardness." *Journ. Inst. Mech. Eng.*, Oct., 1918.
- T. BAKER. "Note on 'The Ball Test.'" *Journ. Iron and Steel Inst.*, May, 1920

#### NATURE OF HARDNESS.

- BELBY. "Hard and Soft State in Metals." *Phil. Mag.*, August, 1904.
- BOYNTON. "Hardness of Constituents of Iron and Steel." *Journ. Iron and Steel Inst.*, 1906, vol. ii, p. 287; 1908, vol. ii, p. 133.
- E. MEYER. "Hardness Testing and Hardness." *Zeitschrift des Vereines deutscher Ingenieure*, April and May, 1908.
- A. KURTH. "Relation Between Hardness, Elastic Limit, and Energy of Tenacious Metals." *Zeit. d. Vereines deutscher Ingen.*, Sept., Oct., 1908.
- CARL BENEDICKS. "The Hardness and Electric Resistance of Metallic Solid Solutions." *Zeit. f. anorg. Chemie*. Bd. 61, 1909, p. 181.
- GUILLERY. "Hardness." *Proc. Int. Assoc. Test. Mat.*, New York, 1912.
- DESCH. "Hardness of Solid Solutions." *Trans. Faraday Soc.*, June, 1914.
- SHORE. "Hardness." *Engineering*, 1914, vol. xcvi, p. 84.
- K. HONDA. "Mechanical Theory of Hardness of Metals." *Science Reports of the Tohoku Imperial University*, July, 1917, vol. vi, No. 2, p. 95.
- SHORE. "Relation between Ball Hardness and Scleroscopic Hardness." *Journ. Iron and Steel Inst.*, 1918, vol. ii, p. 59.



THOMPSON. "Some Recent Advances in the Measurement of the Hardness of Metals." Journ. Soc. Chem. Ind., July, 1919, vol. xxxviii, No. 13, p. 243.

## MISCELLANEOUS.

BOTTONE. "Relation of Atomic Volume to Hardness." Les Mones, t. xxxi, p. 720; Chem. News, 1873, vol. xxvii, p. 215.

BENEDICKS. "Relation of Osmotic Pressure to Hardness." Zeitschr. f. Physik. Chemie., 1901, vol. xxxvi, p. 529.

SCHROEDER. Verhandl. d. k. Akad. Wet., Amsterdam, vol. viii, sect. 2, No. 2, 1902.

ROSIVAL. Verhandl. Geol. Reichsanst., 1902, p. 234.

TRAUBE. "Relation of Internal Pressure to Hardness." Zeitsch. Anorg. Chem., 1903, 34, p. 413; 1904, 40, p. 377; Ber., 1909, 42, p. 1594.

MULLER. Inaug. Diss., Jena, 1906.

EDWARDS and WILLIS. "A Law Governing the Relation of Resistance to Penetration of Metals when Tested by Impact with a 10-mm. Steel Ball." Proc. Inst. Mech., Eng., Oct., 1918.

MCCANCE. "Hardness Test as an Indication of the Distribution of Stress Resulting from Cold Work." Trans. Inst. Eng. and Shipbuilders, April, 1919, vol. lxii, p. 2.

- ANNEALING, effect of, on mechanical properties, 67  
of cold worked steel, 273  
of high speed steel, 290
- ANTIMONY, cooling curve, 168  
surfusion in, 171
- ARNOLD, alternating stress test machine, 99
- ARRANGEMENT OF FIBRES IN STEEL, 32
- ATCHERLEY, bend testing machine, 98, 324
- AVERY, impact testing machine, 304
- AXIAL LOADING, 89  
shackles, 90, 302
- BALL BEARING STEEL, 215
- BASE PYRAMIDS IN INGOTS, 21
- BASIC LININGS, 9
- BASIC PROCESS, Bessemer, 7  
open-hearth, 11  
electric, 13
- BASIC STEEL, chemical composition of, 152  
mechanical properties of, 151  
plain carbon, 149
- BEAM TESTS, on case-hardened steels, 249
- BENDING TESTS, 96  
method, 97  
tools, 97  
reverse, 98
- BESSEMER, process, 4  
converter, 4  
reactions, 5  
ingots, 9
- BLOWN METAL, 5
- BLUEING, of cold worked steel, 269  
effect of, on reverse bends, 271
- BREARLEY, 31
- BRINELL, ball hardness test, 90  
machine, 91, 317  
relationship of number to tensile strength, 91  
Table of Brinell Hardness Numbers, 92  
overloading in test, 91  
preparation of surface for test, 92  
on soft materials, 92

BRINELL, proper loads, 93

BRINELL TESTS ON STEELS AT HIGH TEMPERATURES, 300

BRITTLENESS IN COLD WORKED STEELS, 267

CALIBRATION OF CHARPY MACHINE, 306

CARBIDE, free, 232, 234

CARBON CONTENT OF CARBON TOOLS, 282

CARBON STEEL TOOLS, carbon content of, 282

effect of reheating on mechanical properties of, 286

hardening of, 283

hardening temperature of, 284

structure of, 283

tempering of, 284

tempering temperature of, 285

tempering colours of, 286

CARBON STEELS, effect of carbon content on mechanical properties, 140

fatigue range of, 153, 154

impact value of, 155

manganese in, 143

mass effect in heat treatment of, 149, 150

mechanical properties of heat treated, 146, 147

mechanical properties of acid and basic, 152

soundness of, 156

sulphur and phosphorus in, 143, 157, 160

CARBURISING, process, 222

by gas, 223

mixtures, 224, 225

prevention of, 262

speed of, 228, 230

tests of mixtures, 226

temperatures, 226, 228

CASE, of case-hardened parts, 217

air-hardening, 235

effect of alloys on refining temperature of, 234

formation of, 227

function of, 218, 219

hardening of, 233

proper depth of, 231

- CASE, mechanical tests of, 243, 244
  - refining of, 233
- CASE-HARDENING PROCESS, 222
- CASE-HARDENING STEELS, distribution of carbon in, 217
  - typical, 220
  - typical, chemical composition of, 221
  - typical, mechanical properties of, 221
  - physical properties of, 247
  - elastic limit and fatigue range of, 255
  - distortion of, 255
  - volume changes in, 256
  - defects in, 259
- CASTING, hot, 21
  - cold, 21
  - temperatures, 21
- CEMENTED BAR, 3
- CHARPY MACHINE, 96, 305, 306
- CHAUCER, 37
- CHEMICAL COMPOSITION, of commercial carbon steel, 142
  - of alloy steels, 197
  - of air-hardening steels, 175
  - of plain carbon steels, 142
  - of oil-hardening nickel chromium steels, 179, 183, 189
  - of nickel steels, 195
  - of chromium vanadium steels, 191
  - of stainless steel, 211
  - of ball-bearing steel, 214
  - of case-hardening steel, 221
  - of carbon tool steel, 282
  - of high speed steel, 287
- CHOICE OF BEST ALLOY STEELS, 203
- CHROMIUM STEELS, mechanical properties of, 94
- CHROMIUM VANADIUM STEELS, chemical composition of, 191
  - mechanical properties of, 192, 193
- COKER, 293
- COLD WORKED STEELS, manufacture of, 265
  - softening of, 265
  - effect of cold work on mechanical properties of, 266, 267

- COLD WORKED STEELS, brittleness in, 267  
 heat treatment of, 269  
 heat treatment of, effect of, on mechanical properties, 268  
 heat treatment of, effect on structure of, 271  
 elastic limit of, 270  
 recrystallisation of, 272  
 annealing of, 273  
 globularising of, 274  
 effect of chemical composition on mechanical properties of, 276, 277  
 fatigue range of, 279, 280
- COLUMNAR CRYSTALS, 18
- CONTRACTION STRESSES IN HEAT TREATMENT, 75, 77, 79
- CONTRACTION, fluid, 24  
 solid, 25  
 cavities, 26, 33
- COOLING CURVES, 44, 47
- CORE OF CASE-HARDENED PARTS, functions of, 218, 219  
 refining of, 238  
 mechanical testing of, 244  
 strong and weak, 253
- CORNERS, sharp, 78, 82, 293
- COST OF STEEL-MAKING PROCESSES, 14
- CRITICAL POINTS, 50  
 of nickel steels, 55  
 of chromium steels, 57
- CRITICAL VOLUME CHANGES, 76
- CRUCIBLE, process, 2  
 ingots, 3
- CRYSTALS, columnar, 18  
 needle-like, 18  
 free, 20  
 dendritic, 22
- "CUPPED" WIRE, 278
- DEFECTS, surface, 32  
 in case-hardening steels, 259
- DEFINITIONS OF HEAT TREATMENT PROCESSES, 39
- DENDRITES, DENDRITIC CRYSTALS, 22

DEPTH OF CASE, 231  
DERIHON BALL TESTING MACHINE, 91, 321  
DIFFUSION OF CARBON IN CASE-HARDENING STEELS, 227  
DISTORTION BY HOT WORKING, 37  
DISTORTION IN STEEL (LOCAL), 123  
DISTORTION OF CASE-HARDENING STEELS, 255  
DISTORTION OF STRUCTURES, 83  
DISTRIBUTION OF CARBON IN CASE-HARDENING STEELS, 217  
DISTRIBUTION OF SULPHUR AND PHOSPHORUS IN STEEL, 159  
"DOUBLING," 3  
DRILLS, 4  
DUCTILITY, 82

EDEN (ROSE, & CUNNINGHAM), 102  
ELASTIC LIMIT, 70  
    definition of, 107  
    of alloy steels, 108, 109  
    of alloy steels, effect of tempering on, 110, 111  
    effect of strains on, 112, 113  
    of case-hardening steels, 253  
    of cold worked steels, 270  
    effect of fatigue stresses on, 133  
ELASTICITY, MODULUS OF, 297  
    at high temperatures, 298  
ELECTRIC STEEL MELTING, 11  
    arc process, 12  
    basic process, 13  
ELONGATION, 119  
    effect of gauge length on, 120, 121  
    effect of fibre on, 122  
    of sheets, 123  
ENGINEERING VALUE OF HEAT TREATED STEEL, 81  
EXTENSOMETER, 90

FATIGUE, effect of, on elastic limit, 133  
    testing methods, 102, 104  
FATIGUE RANGE, general, 101  
    observations in test, 102  
    relation of, to elastic limit, 130  
    effect of different plus and minus stresses on, 181  
    relation of, to maximum stress, 136

- FATIGUE RANGE, definition, 129  
values, 137  
of plain carbon steel, 153, 154  
of alloy steels, 207, 209, 210  
of case-hardening steels, 255  
of cold worked steel, 279, 280
- FATIGUE STRESS, 130  
effect of, on elastic limit, 133
- FERRO-MANGANESE, 6
- FERRO-SILICON, 11
- FIBRE, 28, 29  
effect of, on elongation and reduction of area, 122  
effect of, on impact, 128  
arrangement of, 32  
effect of, on mechanical properties, 30, 31
- FILE TESTS, 243
- FINE GRAIN, 63, 64
- FLAKING, 260
- FLUCTUATING STRESS, 133
- FORGING CRACKS, 33
- FORMATION OF CASE IN CASE-HARDENED PARTS, 227
- FRACTURE TESTS OF CASE-HARDENING STEELS, 246  
effect of slag  
upon, 247
- FREE CARBIDE, 232, 234
- FREE CRYSTALS, 20
- FREEZING RANGE, 22
- FUNCTIONS OF CASE IN CASE-HARDENED PARTS, 218, 219
- FUNCTIONS OF CORE IN CASE-HARDENED PARTS, 218, 219
- FURNACES, Bessemer, 4  
open-hearth, 10  
crucible, 2  
electric, 12
- GAUGE LENGTH, standard, 121  
reduced diameter in, 90  
effect of, on elongation, 120, 121
- GHOSTS, 34
- GLOBULARISING, 274
- GRAIN (FINE), 64, 65
- GRIFFITHS, 293

- HAIGH FATIGUE TEST, 103  
    machine, 312  
    specimen, 316
- HAIR LINES (CRACKS), 33
- HARDENING, definition of, 39  
    mass effect in, 70  
    in air, 166  
    of case-hardening steels, 233  
    of case-hardening steels, method of, 236  
    of case-hardening steels, temperature for, 238
- HARDENING TEMPERATURE, 51  
    of high carbon steels, 53  
    of tools, 284
- HARDNESS, tests, 93, 105  
    bibliography of original papers on, 327  
    of tools, 283
- HEAT TREATMENT, definitions, 38  
    processes, 38  
    why possible, 39  
    of cold worked steels, 267  
    of high-speed steels, 289
- HEATING CURVES, 51
- HIGH-SPEED STEEL, 4  
    tools, 289  
    heat treatment of, 289  
    mechanical properties of, 289  
    softening of, 290
- HOT CASTING, 21
- HOT WORKING, 27
- HUNTSMAN, 2
- IMPACT TEST, 94, 125, 138  
    stress/strain curve of, 125  
    effect of maximum stress on, 126  
    effect of fibre on, 128
- IMPACT VALUES, of plain carbon steels, 155  
    of alloy steels, 196  
    of carburised specimens, 250  
    of steels at high temperatures, 301
- INGOTS, crucible, 3  
    Bessemer, 9



- INGOTS, sections of, 20, 21, 25  
    base pyramids in, 21  
    zone of weakness in, 23
- INTERMITTENT PIPE, 34
- IRON CARBIDE, 49
- IRON CARBON SYSTEM, 48
- IRON OXIDE, 6
- IZOD notch, 94, 96  
    machine, 96
- JOHNSON BALL HARDNESS TESTING MACHINE, 91, 321
- KRUPP KRANKHEIT, 185  
    avoidance of, 187  
    susceptibility to, 187
- LEAD/TIN, mixture, 43  
    system, 44
- LEE REVERSE BEND TESTING MACHINE, 323
- LIMIT OF PROPORTIONALITY, 107
- LIMITS OF SULPHUR AND PHOSPHORUS IN PLAIN CARBON STEEL, 160
- LOCAL DISTORTION OF STEEL, 123
- LOW TEMPERATURE BRITTLENESS, 180
- LOW TEMPERATURE TEMPERING OF AIR-HARDENED STEEL, 178
- MACHINABILITY, effect of chemical composition on, 198
- MANGANESE in crucible steel, 3  
    in Bessemer steel, 6  
    in open-hearth steel, 11  
    in plain carbon steel, 143  
    effect of, on mechanical properties of normalised plain carbon steel, 143  
    effect of, on mechanical properties of heat treated plain carbon steel, 144  
    effect of, on mass effect in heat treatment, 145
- MARGINS OF MANUFACTURE IN COLD DRAWN STEELS, 278
- MASS EFFECT IN HEAT TREATMENT, 70  
    principles, 71  
    effect of, on structure, 72

MASS EFFECT IN HEAT TREATMENT, effect of, on mechanical properties, 72  
 in tempering, 73  
 in normalising, 73  
 effect of, on volume changes, 79  
 of low nickel, 21  
 chromium steels, 21  
 of plain carbon steels, 21  
 in hardening alloy steels, 199  
 of case-hardening steels, 240

MAXIMUM STRESS, 118  
 of steels at high temperatures, 298

MECHANICAL TESTING OF CASE-HARDENING STEELS, 242  
 of case-hardening steels, 242  
 of alloy steels, 242

MECHANICAL PROPERTIES OF STEELS, 107  
 effect of tempering, 60  
 of heat treated plain carbon, 149  
 of acid and basic steels, 151  
 of air-hardening steels, 177  
 of oil-hardening steels, 180, 183, 190, 192, 194, 194  
 of case-hardening steels, 221  
 of cold worked steel, 212  
 of stainless steel, 212  
 of high-speed steel, 212  
 typical of alloy steels, 196  
 of carbon steel tools, 196

MESNAGER NOTCH, 94, 96

- METHOD OF COOLING CASE-HARDENING STEELS, for hardening, 236  
in refining, 239
- MODULUS OF ELASTICITY, 297  
of steels at high temperatures, 298
- NEEDLE-LIKE CRYSTALS, 18
- NICKEL CHROMIUM STEELS, air-hardening of, 59  
air-hardening, 175  
oil-hardening, 179, 181, 189, 190
- NICKEL STEELS, critical points of, 55  
air-hardening of, 57  
chemical composition of, 195  
mechanical properties of, 195
- NON-METALLIC IMPURITIES AND INCLUSIONS, 22, 25 32
- NORMAL VOLUME CHANGES, 74
- NORMALISING, definition of, 39  
of steel, 63  
temperature of, 65  
effect of, on strains, 66  
mass effect in, 73
- NOTCH, Izod, 94, 96  
Mesnager, 94, 96
- NOTCHED BAR (see *Impact*)
- OBSERVATIONS IN FATIGUE TESTS, 102
- OIL-HARDENING ALLOY STEELS, 175, 181, 189, 190, 191, 194, 195, 211
- OIL-HARDENING, CASE-HARDENING STEELS, 236, 242
- OPEN-HEARTH PROCESS, acid, 10  
basic, 11
- OVERDRAWING, 278
- OVERLOADING IN BRINELL TEST, 91
- OXIDE OF IRON, 6
- PATENTING, 274
- PEARLITE, 50
- PHOSPHORUS, in acid Bessemer process, 7  
in basic Bessemer process, 8  
in plain carbon steels, 143, 157  
in plain carbon steels, limits of, 160  
in plain carbon steels, distribution of, 159

PHYSICAL PROPERTIES OF CASE-HARDENING STEELS, 231  
PIPE, 24, 34, 36  
PIPE, intermittent, 34  
PLAIN CARBON STEEL (see *Carbon Steels*)  
PREVENTION OF CARBURISATION, 262  
PREVENTION OF DISTORTION, 258  
PROOF STRESS, 117, 138  
PROPORTIONALITY, limit of, 107  
PYRAMID IN BASE OF INGOT, 21

QUENCHING, 50

QUENCHING STRAINS, 112  
effect of, on elastic limit, 112, 113

RAILWAY TYRES, 74

RAZORS, 4

RECRYSTALLISATION OF COLD WORKED STEEL, 272

REDUCTION OF AREA, 119  
effect of fibre on, 122

REFINING CASE OF CASE-HARDENING STEEL, 233  
effect of alloy on,  
234

REFINING CORE OF CASE-HARDENING STEEL, 238  
method of cooling  
for, 239  
temperature, 238

RETARDATION TEMPERATURES, 45, 47

REVERSE BEND TEST, 98, 271

ROAKS, 33

ROBERTSON, 90, 302

ROUGH MACHINING, 32

ROUGH TURNING OF ALLOY STEELS, 206

SALT SOLUTIONS, 40

SALT/WATER SYSTEM, 42

SCLEROSCOPE, 105

SEAMS, 32

SEGREGATION, 34, 157

SHACKLES, axial loading, 90

SHARP CORNERS, 78, 82, 293

SHEETS, elongation in, 123

- SHORE, 105
- SKIN DEFECTS, 32
- SLAG STREAKS, 32, 34, 261
- SOFTENING, 39, 68  
    temperature, 69  
    of air-hardening steel, 176  
    of oil-hardening steel, 181  
    of cold worked steel, 265  
    of high-speed steel, 290
- SOFT SPOTS, 259
- SOLIDIFICATION, 17, 32
- SOLID CONTRACTION, 25
- SOLID SOLUTION, 49  
    viscosity of, 167  
    stability of, 57, 58  
    stability of, effect of manganese on, 58
- SOLUBILITY OF STEEL IN ACIDS, 61
- SORBITE, 275
- SOUNDNESS OF PLAIN CARBON STEELS, 156
- SOUNDNESS OF ALLOY STEELS, 205
- SPECIFIC GRAVITY OF TEMPERED STEELS, 81
- SPEED OF CARBURISATION, 228, 230
- STAINLESS STEEL, 209  
    chemical composition of, 211  
    mechanical properties of, 212  
    critical temperatures of, 214
- STANDARD GAUGE LENGTH, 121
- STANTON TEST, 99  
    machine, 308, 309
- STEEL, crucible, 2  
    Bessemer, 6  
    open-hearth, 10  
    electric, 13  
    high speed, 4  
    solubility in acids of, 61  
    mechanical properties of, 107  
    plain carbon, 140  
    100-ton, 175  
    75-ton, 179  
    60-ton, 181

- STEEL, 40-ton, 195
  - stainless, 209
  - ball-bearing, 215
  - case-hardening, 217
  - cold worked, 265
  - tool, 281
- STRAINS, quenching, 112
- STRESS, due to volume changes, 75
  - due to critical volume changes, 77
  - effect of sharp corners on, 78, 293
  - contraction, 75, 77, 79
  - alternating, 99
  - proof, 107, 138
  - maximum, 118
  - fatigue, 130
  - fluctuating, 133
- STRESS/STRAIN CURVE, 108
  - effect of tempering on, 113
  - of impact test, 125
- STROHMEYER, 104
- STRONG CORES, 253
- STRUCTURE (MICRO), of tempered steels, 63
  - effect of high temperatures on, 64
  - effect of annealing on, 67
  - effect of normalising on, 65
  - effect of mass on, 72
  - effect of, on mechanical properties, 84
  - of cold worked steels, 271
  - of tools, 283
- SULPHIDES, 35
- SULPHUR, in acid Bessemer, 7
  - in basic Bessemer, 8
  - in plain carbon steels, 143, 157
  - limits of, 160
  - distribution of, 159
- SULPHUR PRINTS, 36
- SURFACE DEFECTS IN ALLOY STEELS, 204
- SURFUSION IN CHROMIUM STEELS, 169
- SURFUSION IN AIR-HARDENING STEELS, 170
- SUSCEPTIBILITY OF KRUPP KRANKHEIT, 187
- SWEDISH BRINELL MACHINE, 91

TAPS, 4, 73

TAYLOR, 293

TEMPERATURE, effect on structure of high, 64

TEMPER BRITTLENESS, 185

avoidance of, 187

TEMPERING, 39, 59

maximum temperature of, 59

effect of, on mechanical properties, 60

effect of, on structure, 60

mass effect in, 73

effect of, upon elastic limit of hardened steels,

110

effect of, on stress/strain curves, 113

of air-hardening steels (theory), 174

at low temperatures, 178

of tools, 284

of tools, temperature of, 285

of tools, colours, 285

TENSILE STRENGTH AT HIGH TEMPERATURES OF STEELS, 300

THERMAL CONTRACTION IN INGOTS, 25

TIN/LEAD SYSTEM, 43, 44

TOOL MARKS, 83

TOUGHNESS, 82, 87

TYPICAL MECHANICAL PROPERTIES OF ALLOY STEELS, 196

TYPICAL CASE-HARDENING STEELS, 220

UPTON LEWIS, 101

VALUABLE MECHANICAL PROPERTIES OF STEELS, 138

VANADIUM, 191

VISCOSITY OF SOLID SOLUTIONS, 167

VOLUME CHANGES, in heat treatment, 74

normal, 74

stress due to, 75

critical, 76

stress due to, 77

effect of mass on, 79

in tempering, 80

in case-hardening steels, 256

WEAK CORES IN CASE-HARDENED PARTS, 253

WÖHLER TEST, 102

WÖHLER MACHINE, 103

YIELD-POINT, definition, 116

difficulties of determining, 117

YOUNG'S MODULUS, 297

at high temperatures, 298

ZONES OF WEAKNESS IN INGOTS, 23





FIG. 1.—ETCHED CROSS SECTION OF INGOT  
SHOWING OUTER LAYER OF CHILLED  
STEEL, ALSO COLUMNAR CRYSTALS.

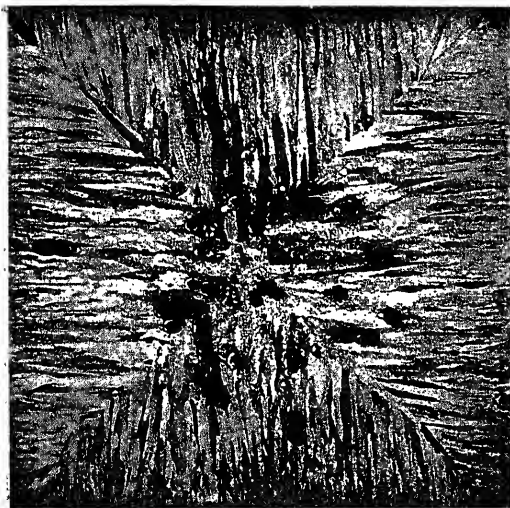

FIG. 2.—ETCHED SECTION OF INGOT SHOWING  
COLUMNAR CRYSTALS.

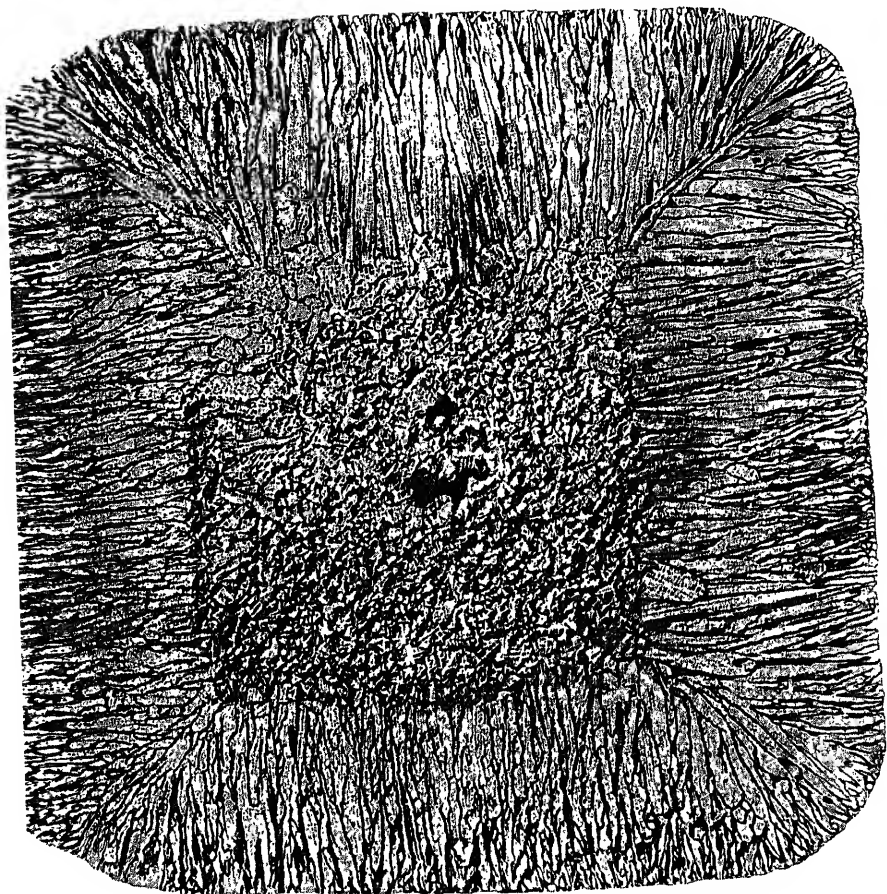

FIG. 3.—ETCHED SECTION OF INGOT SHOWING COLUMNAR  
AND FREE CRYSTALS.

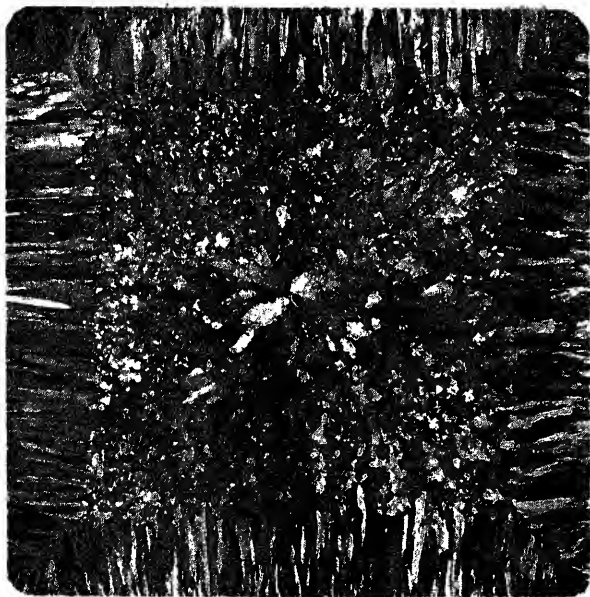

FIG. 4A.—ETCHED CROSS SECTION OF INGOT SHOWING DIFFERENT PROPORTION OF COLUMNAR AND FREE CRYSTALS.

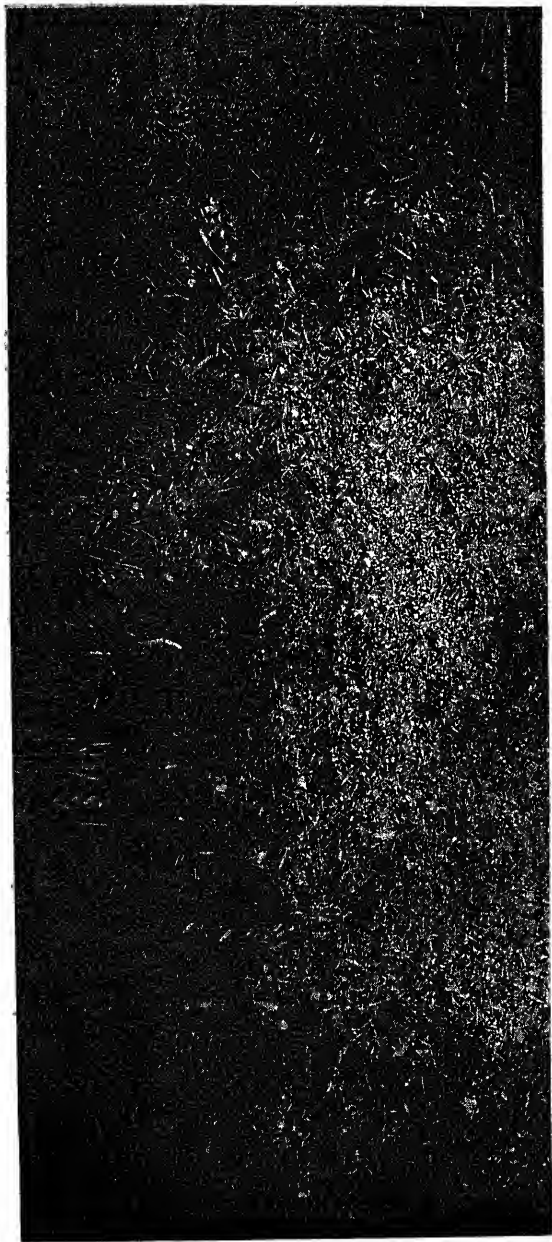

FIG. 4B.—ETCHED HALF-SECTION OF INGOT SHOWING DIFFERENT PROPORTION OF COLUMNAR

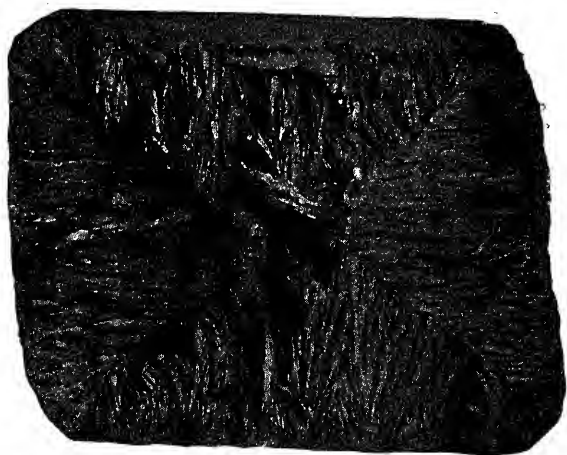

FIG. 5.—CROSS SECTION OF INGOT CAST HOT SHOWING COLUMNAR CRYSTALS EXTENDING FROM THE OUTSIDE TO THE AXIS OF THE INGOT.



FIG. 6.—SECTION OF INGOT SHOW-  
ING EXISTENCE OF BOTTOM  
PYRAMID.

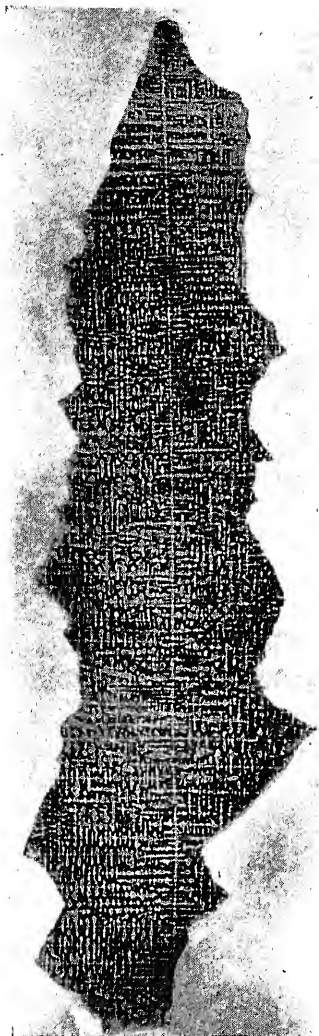

FIG. 7.—ETCHED SECTION OF A SINGLE STEEL CRYSTAL SHOWING DENDRITIC FORMATION.



FIG. 8.—EXTERNAL APPEARANCE OF SINGLE STEEL CRYSTAL.



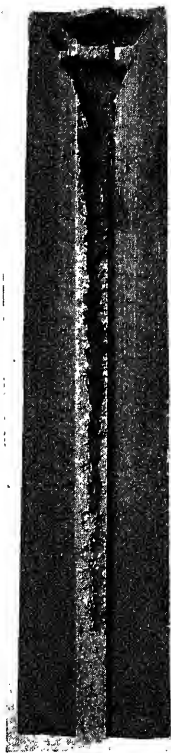

FIG. 9.—LONGITUDINAL SECTION OF  
INGOT SHOWING AXIAL PIPE.



FIG. 10.--ETCHED SECTION OF INGOT SHOWING CONTRACTION CAVITIES HIGH IN NON-METALLIC IMPURITIES, LYING SYMMETRICALLY AROUND THE AXIS OF AN INGOT.

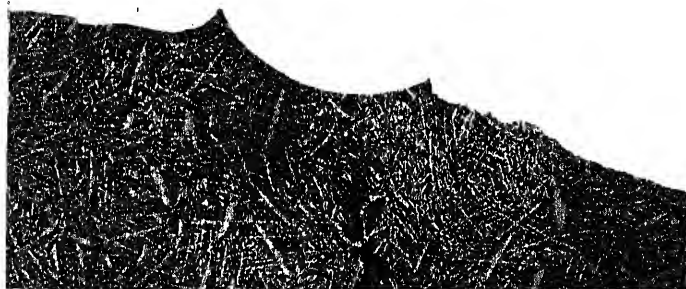

FIG. 12.—ETCHED SECTION OF FORGING IN WHICH THE CRYSTALLINE STRUCTURE OF THE INGOT HAS NOT BEEN OBLITERATED.

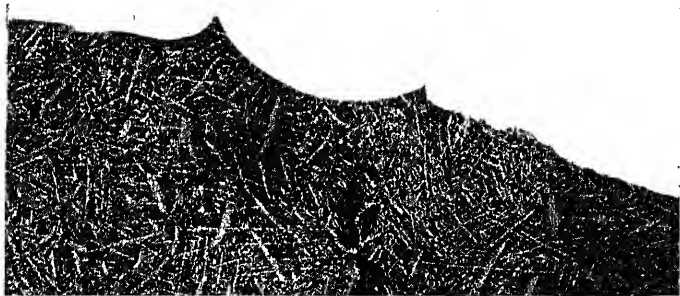

FIG. 12.—ETCHED SECTION OF FORGING IN WHICH THE CRYSTALLINE STRUCTURE OF THE INGOT HAS NOT BEEN OBLITERATED.

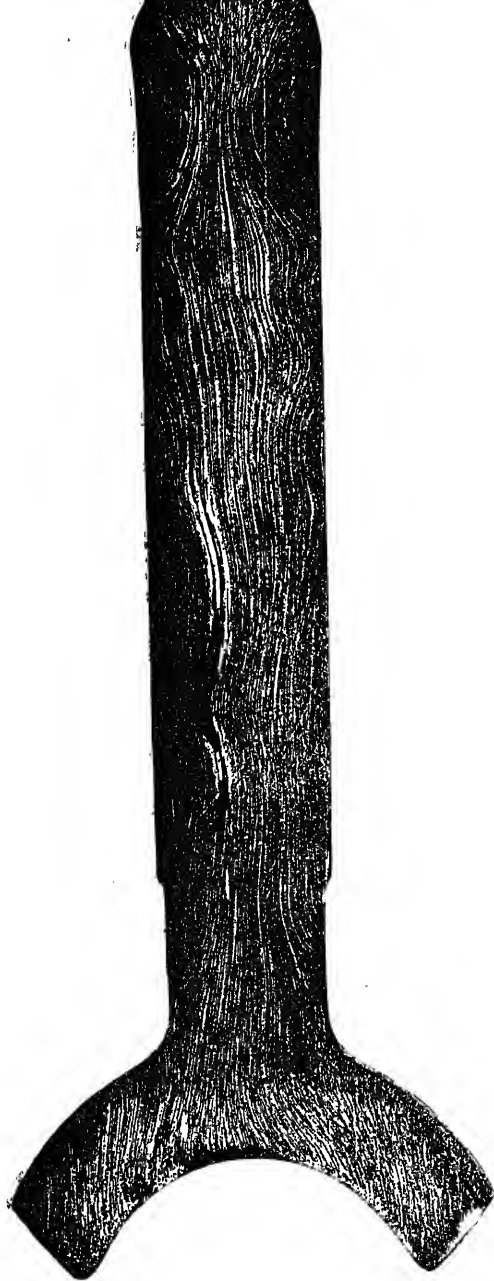

FIG. 13.—ETCHED SECTION OF A FORGING IN WHICH THE  
DIRECTION OF THE GRAIN HAS BEEN

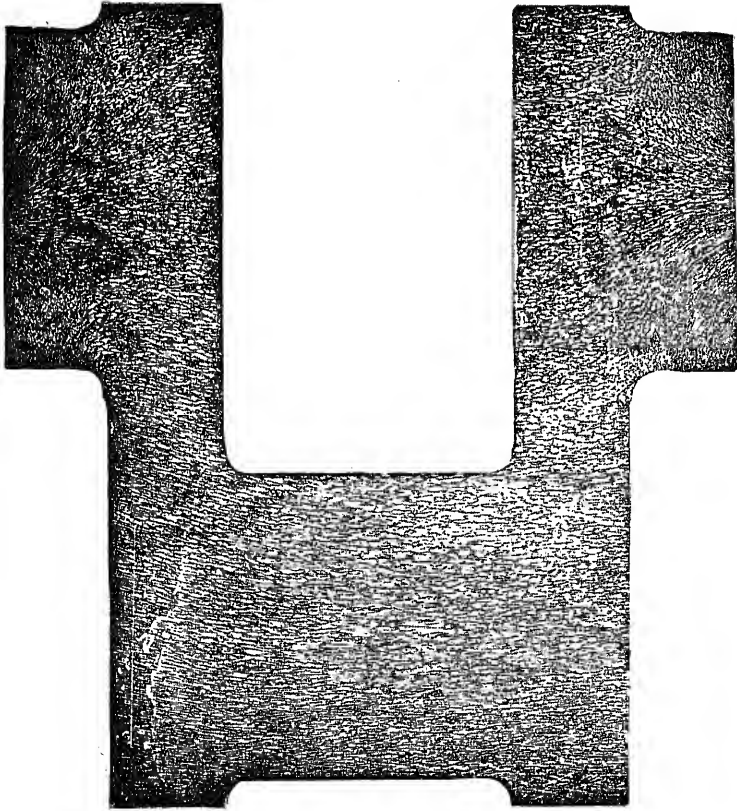

FIG. 16.—ETCHED SECTION OF CRANKSHAFT IN WHICH THE FIBRES OF THE STEEL IN ALL PARTS ARE PARALLEL TO THE AXIS OF THE SHAFT.

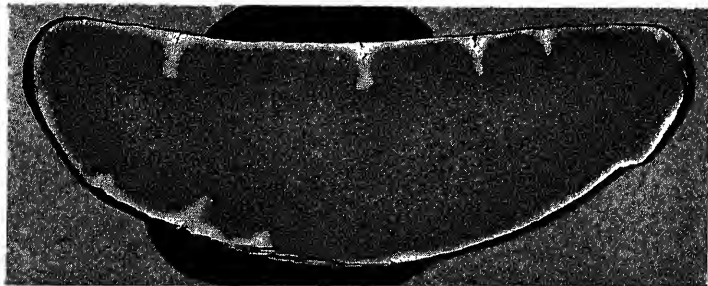

FIG. 17A.—TRANSVERSE SECTION OF STEEL BAR SHOWING ROAKS.

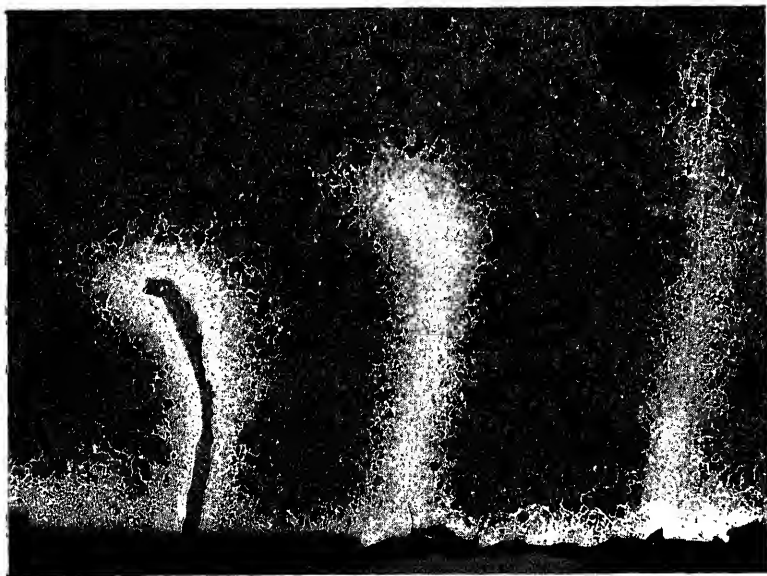

FIG. 17B.—MICROSECTION THROUGH ROAKS IN ROLLED BAR.

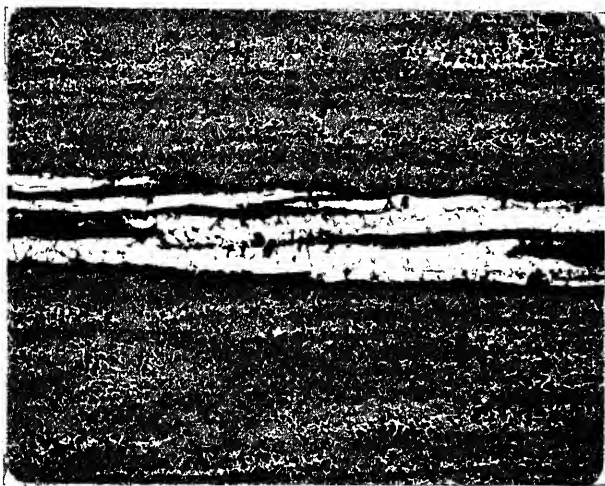

FIG. 18.—MICROSECTION OF STEEL BAR SHOWING SLAG STREAK,  $\times 25$  DIAS.



FIG. 19.—SECTION OF FORGED STEEL SH WING INTERMITTENT PIPE.





FIG. 20.—SULPHUR PRINT OF SECTION OF AN  
INGOT THROUGH AXIAL PIPE.



FIG. 20.—SULPHUR PRINT OF SECTION OF AN  
INGOT THROUGH AXIAL PIPE.



FIG. 21.—SULPHUR PRINT OF A ROLLED BAR SHOWING SEGREGATION OF  
SULPHUR IN AXIS OF BAR.



FIG. 22.—SULPHUR PRINT OF FORGING SHOWING FRACTURE THROUGH REGION HIGH IN SULPHUR (DARK AREAS ARE THOSE HIGH IN SULPHUR).

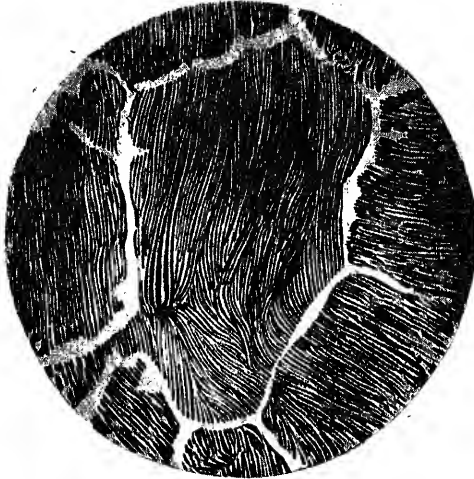

FIG. 28.—MICROSECTION SHOWING PEARLITE,  $\times 500$  DIAS.

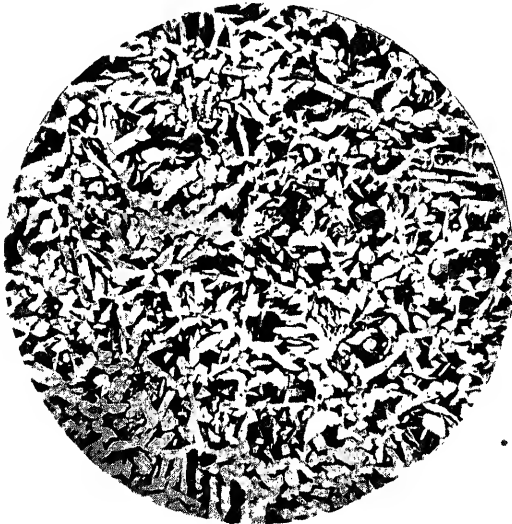

FIG. 29.—MICROSTRUCTURE OF A NORMALISED STEEL CONTAINING 0.30 PER CENT. OF CARBON,  $\times 100$  DIAS.

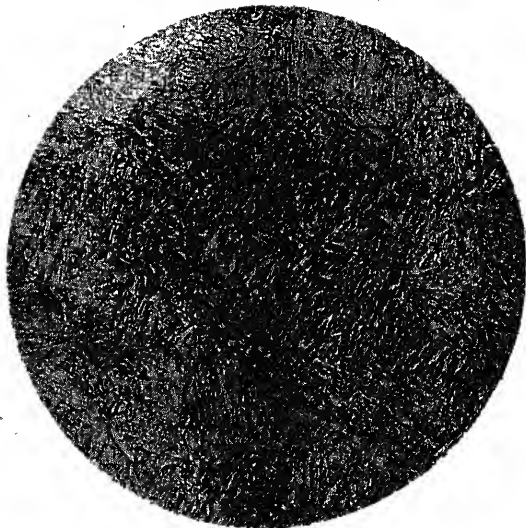

FIG. 30.—MICROSTRUCTURE OF HARDENED STEEL  
CONSISTING ENTIRELY OF SOLID SOLUTION.

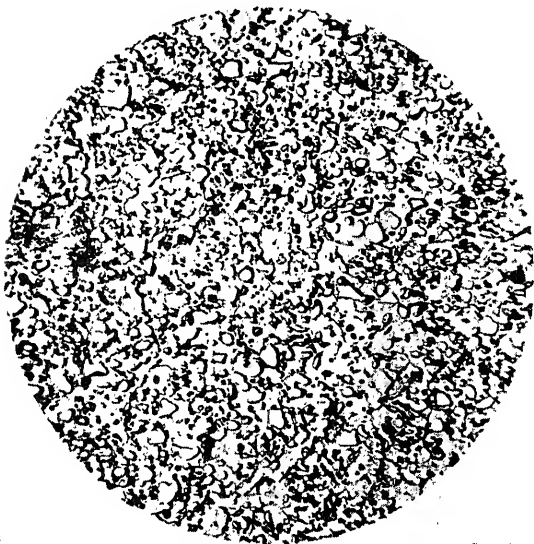

FIG. 34.—MICROSTRUCTURE OF STEEL FULLY  
TEMPERED.

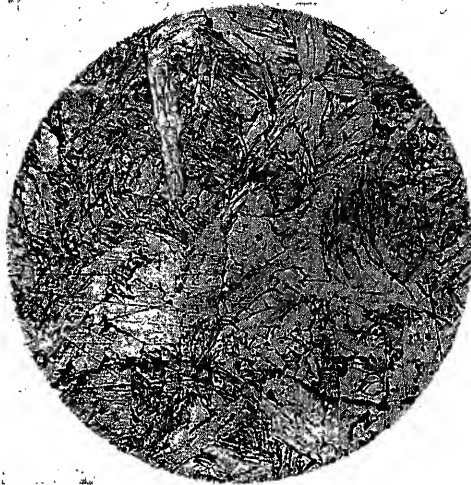

FIG. 35.—MICROSTRUCTURE OF OVERHEATED CARBON STEEL (COOLED FAIRLY RAPIDLY).

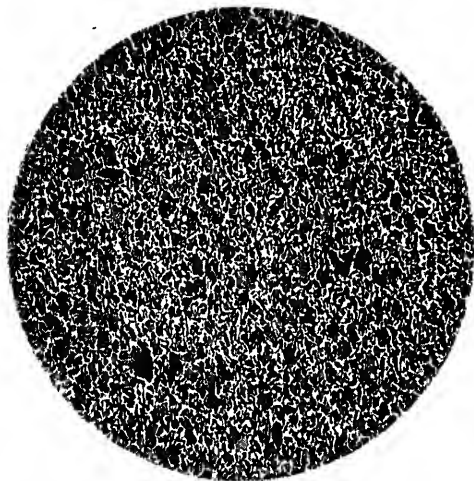

FIG. 36.—MICROSTRUCTURE OF THE STEEL SHOWN IN FIG. 35 AFTER NORMALISING,  $\times 50$  DIAS.



FIG. 37.—MICROSTRUCTURE OF ANNEALED STEEL.

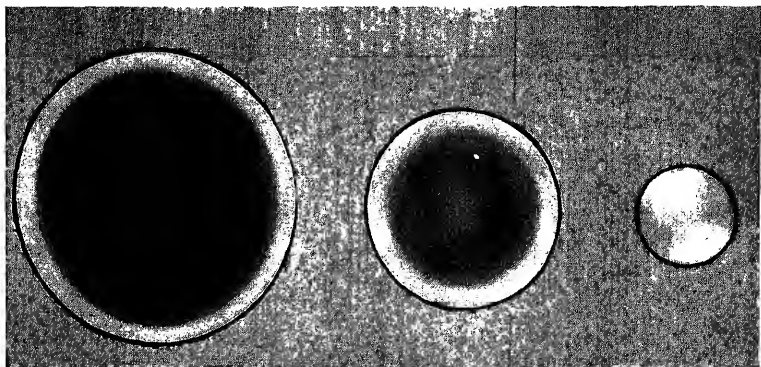

FIG. 38.—ETCHED CROSS SECTIONS OF DIFFERENT SIZED BARS OF CARBON STEEL HARDENED FROM THE SAME TEMPERATURE, SHOWING THE MASS EFFECT IN HARDENING.



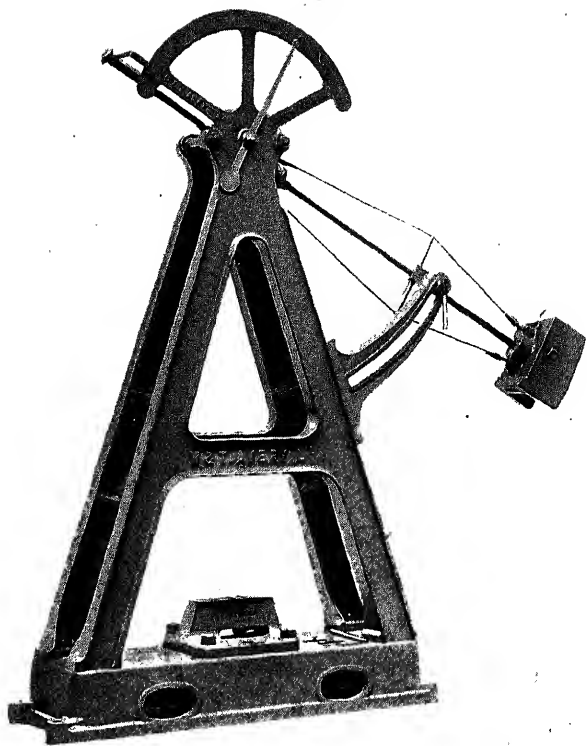

FIG. 44.—IZOD IMPACT TESTING MACHINE.

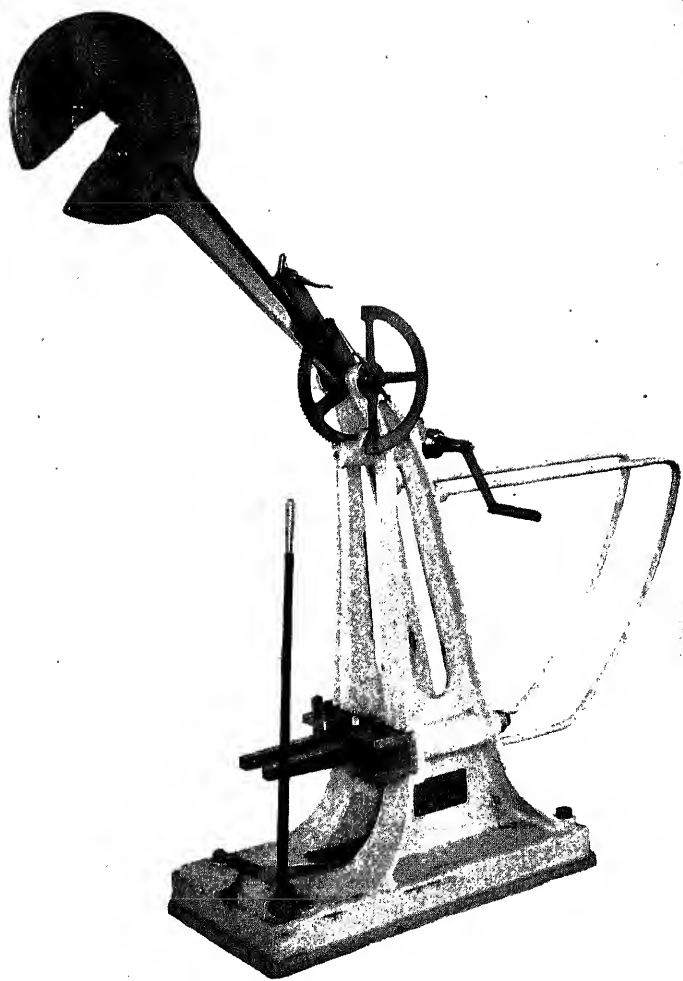

FIG. 45.—CHARPY PENDULUM IMPACT TESTING MACHINE.

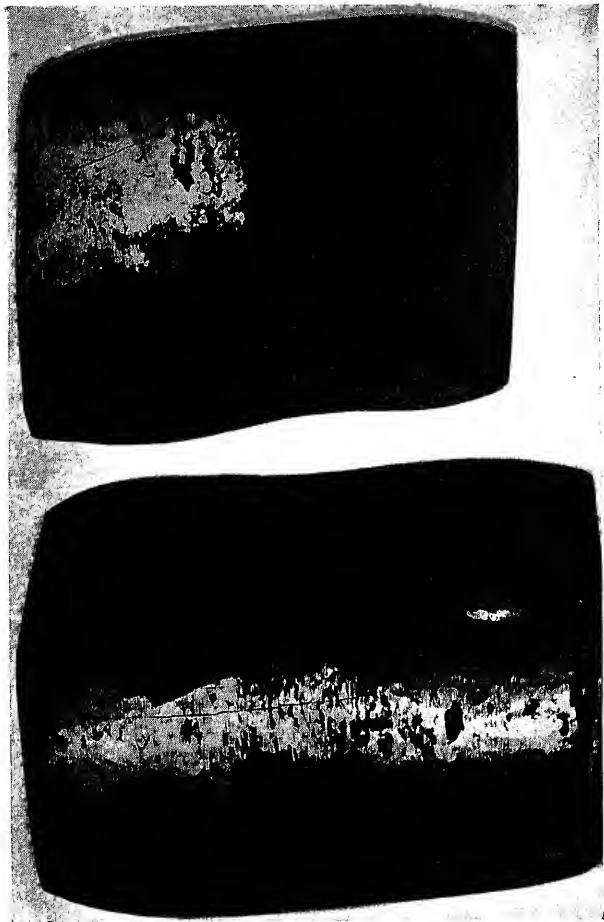

FIG. 70.—BILLETS OF ALLOY STEEL CONTAINING TYPICAL EXTERNAL LONGITUDINAL FLAWS.



FIG. 71.—ALLOY STEEL FORGINGS MADE FROM BILLETS SIMILAR TO THOSE SHOWN IN FIG. 70.

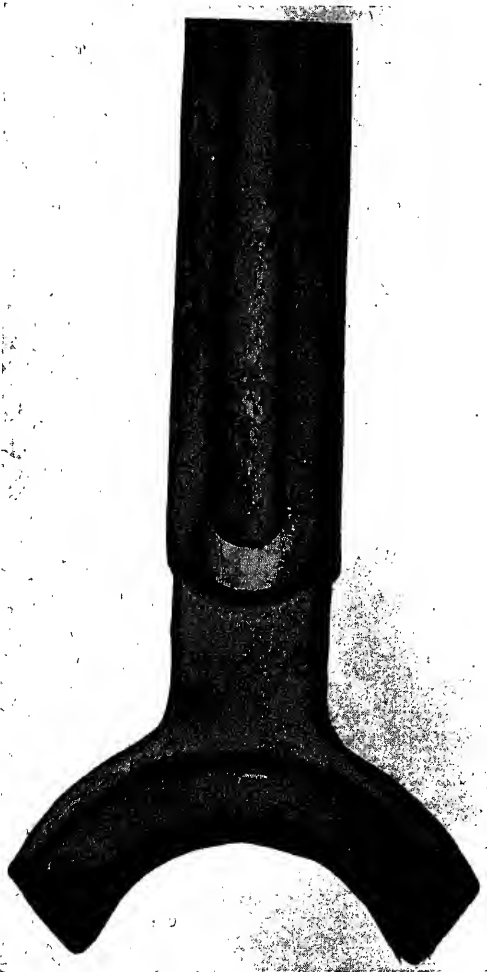

FIG. 72.—DEFECTIVE FORGING MADE FROM APPARENTLY SOUND STEEL WHICH ACTUALLY HAD SURFACE DEFECTS (SEE LONGITUDINAL CRACK AT BOTTOM OF CHANNEL SECTION).

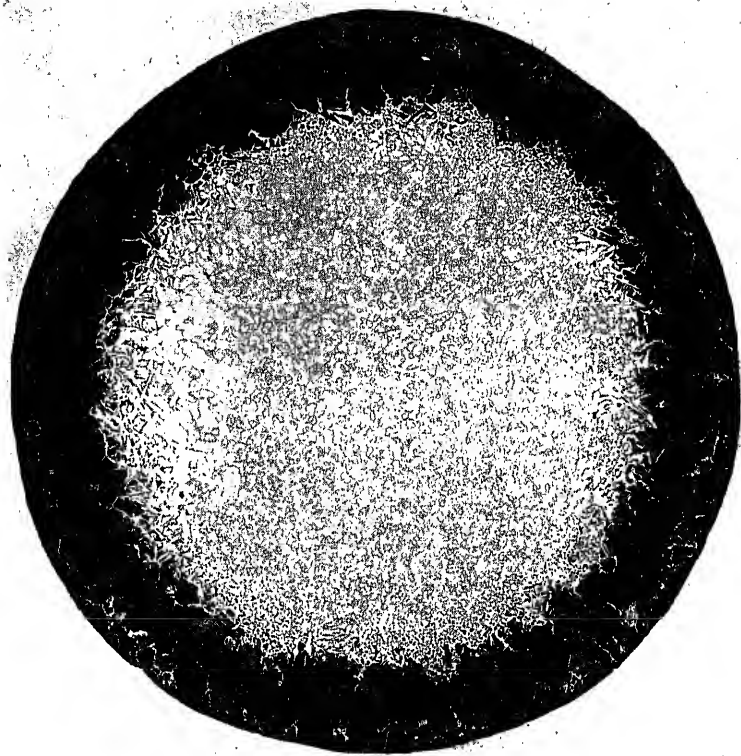

FIG. 76.—COMPLETE ETCHED CROSS SECTION OF A BAR OF CASE-HARDENED STEEL,  $\times 8$  DIAS.

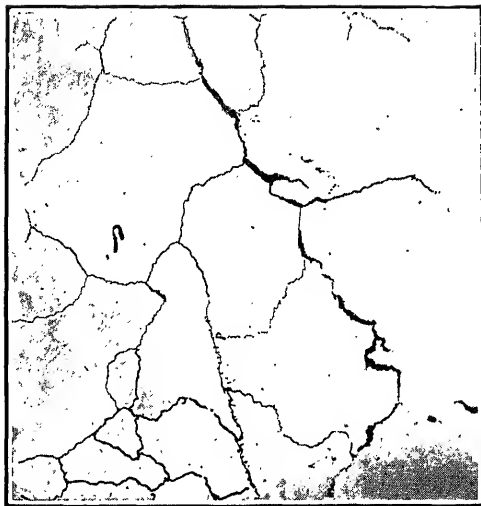

FIG. 81.—MICROSECTION SHOWING CRACKS FOLLOWING FREE CARBIDE IN THE CASE OF A CASE-HARDENED PART.



FIG. 82.—MICROSTRUCTURE OF THE CASE OF A CASE-HARDENED PART AFTER CARBURISING AND BEFORE REFINING,  $\times 50$  DIAS.

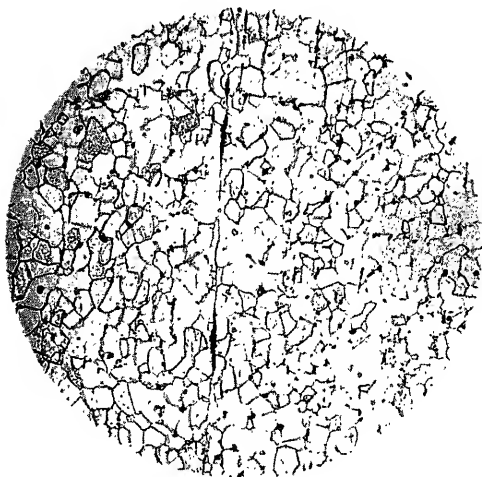

FIG. 83.—MICROSTRUCTURE OF THE STEEL SHOWN IN FIG. 82, AFTER REFINING,  $\times 100$  DIAS.





FIG. 84.—MICROSTRUCTURE OF THE CASE  
OF A CASE-HARDENED PART, SHOWING  
FREE IRON CARBIDE.

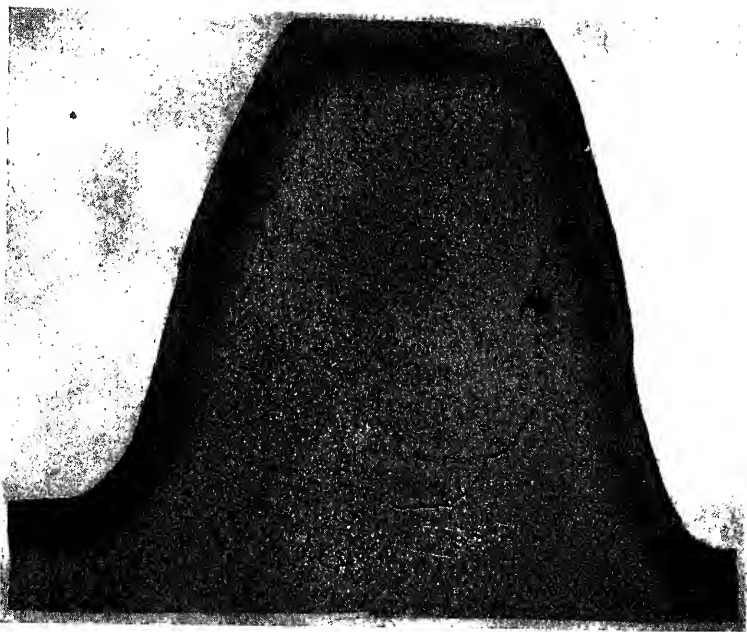

FIG. 85.—ETCHED CROSS SECTION OF A GEAR WHEEL TOOTH, SHOWING  
CRACKS SPREADING FROM FREE CARBIDE IN THE CASE.

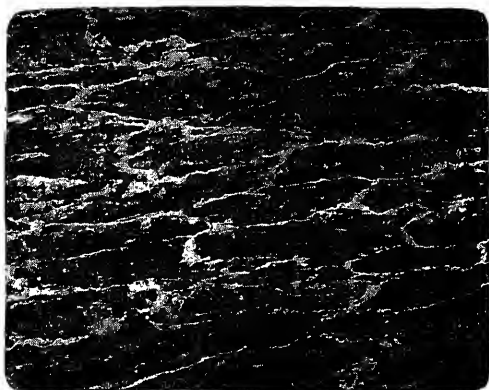

FIG. 88.—MICROSTRUCTURE OF TYPICAL COLD  
WORKED STEEL.



FIG. 89.—MICROSECTION SHOWING THE EFFECT  
OF COLD WORK UPON THE CARBIDE IN A  
STEEL,  $\times$  400 DIAS.



FIG. 90.—MICROSTRUCTURE OF COLD WORKED STEEL AFTER RE-HEATING TO 540° C., SHOWING THE SPLITTING UP OF THE FERRITE GRAINS,  $\times 400$  DIAS.

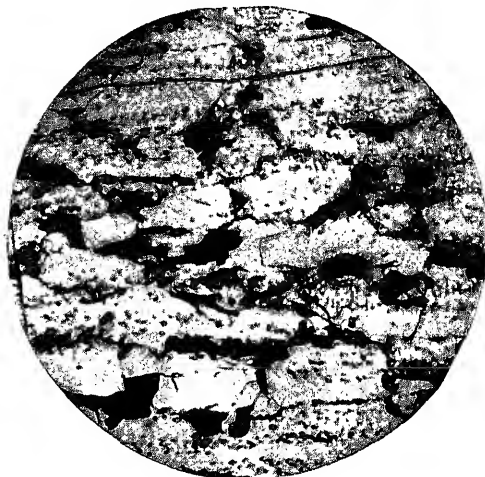

FIG. 91.—MICROSTRUCTURE OF COLD WORKED STEEL AFTER RE-HEATING TO 580° C., SHOWING RE-CRYSTALLISATION OF FERRITE.

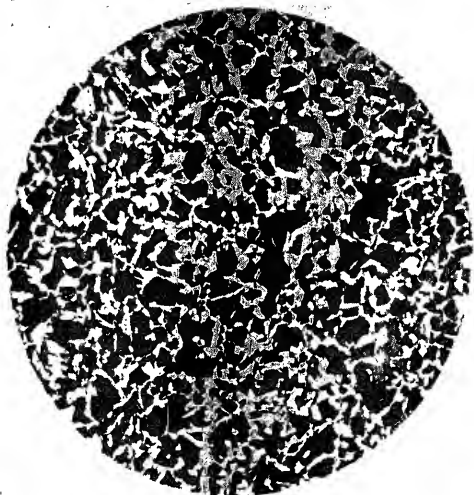

FIG. 92.—MICROSTRUCTURE OF COLD WORKED STEEL AFTER NORMALISING,  $\times 100$  DIAS.



FIG. 93.—MICROSTRUCTURE OF COLD WORKED STEEL "GLOBULARISED" AT  $650^{\circ}\text{C.}$ ,  $\times 500$  DIAS.



FIG. 94.—MICROSTRUCTURE OF PATENTED  
STEEL BAR,  $\times 300$  DIAS.



FIG. 95.—LONGITUDINAL AND TRANSVERSE SECTIONS OF  
BAR OF COLD WORKED STEEL WHICH HAS FRAC-  
TURED BY CUPPING.



FIG. 96.—PHOTOMICROGRAPH OF STRUCTURE OF STEEL CONTAINING 1.10 PER CENT. OF CARBON, NORMALISED,  $\times 500$  DIAS.

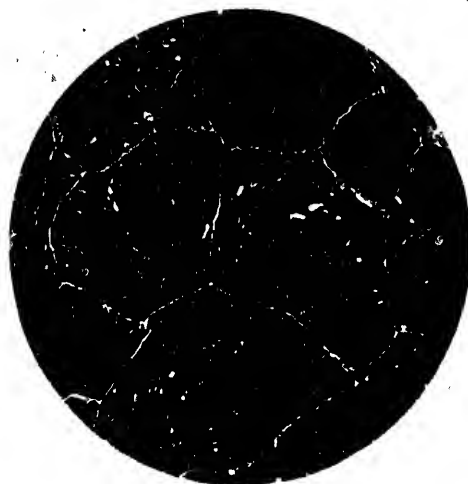

FIG. 97. MICROSTRUCTURE OF STEEL SHOWN



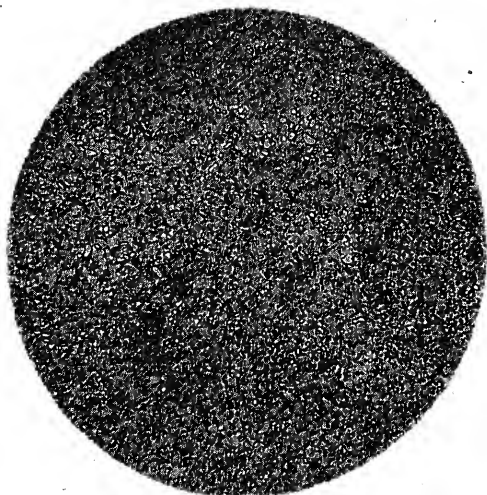

FIG. 98.—MICROSTRUCTURE OF HIGH SPEED-STEEL COOLED IN AIR FROM 1000° C.,  
× 500 DIAS.

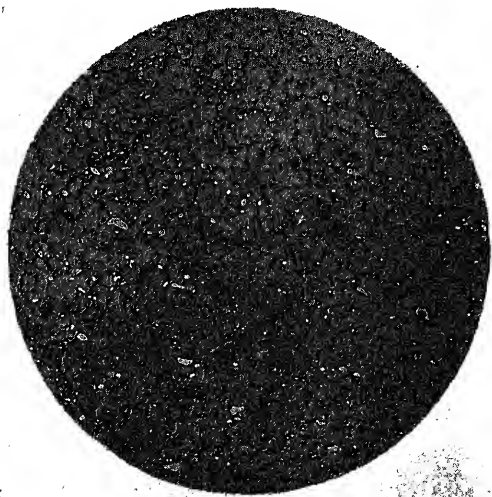

FIG. 99.—MICROSTRUCTURE OF STEEL SHOWN  
IN FIG. 98, COOLED IN AIR FROM 1,250° C.,



FIG. 100.—ETCHED SECTION OF STEEL SHOWING A CRACK IN A FORGING,  $\times 5$  DIAS.

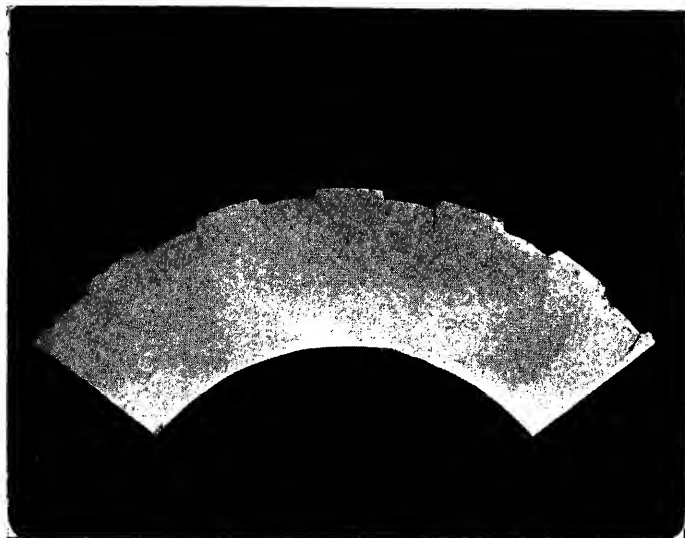

FIG. 101.—SECTION THROUGH CASTELLATIONS ON CRANKSHAFT  
SHOWING CRACKS STARTING AT SHARP CORNERS.



FIG. 102.—SECTION OF STEEL THROUGH A CRACK,  
PRODUCED DURING HEAT TREATMENT, AND  
STARTING AT THE BASE OF A FORGING LAP.



FIG. 102.—SECTION OF STEEL THROUGH A CRACK,  
PRODUCED DURING HEAT TREATMENT, AND  
STARTING AT THE BASE OF A FORGING LAP.

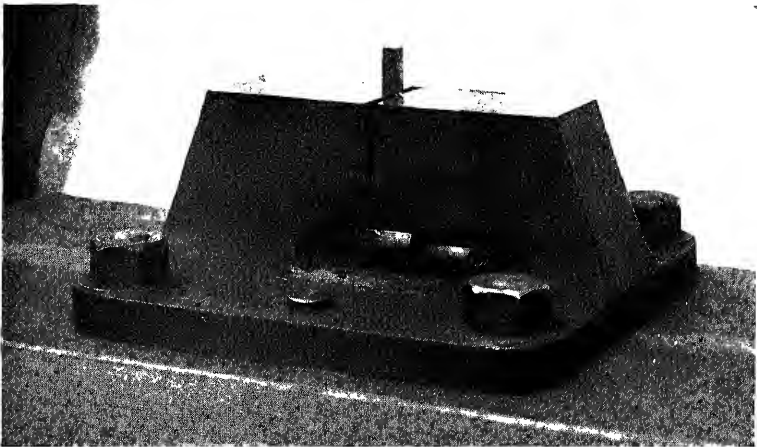

FIG. 104.—BASE BLOCK OF IZOD IMPACT MACHINE WITH TEST  
PIECE IN POSITION.

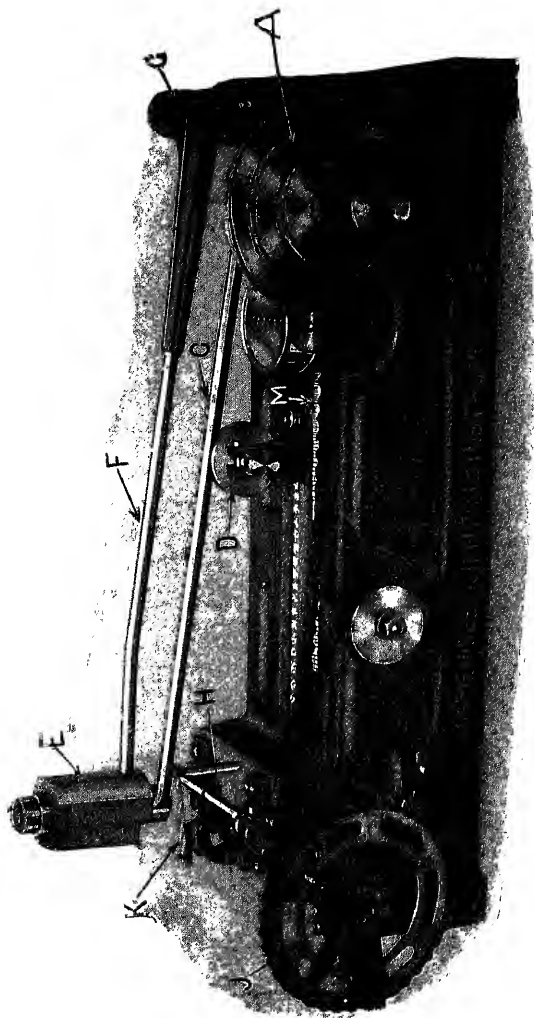

FIG. 105.—GENERAL VIEW OF STANTON REPEATED IMPACT TESTING MACHINE.

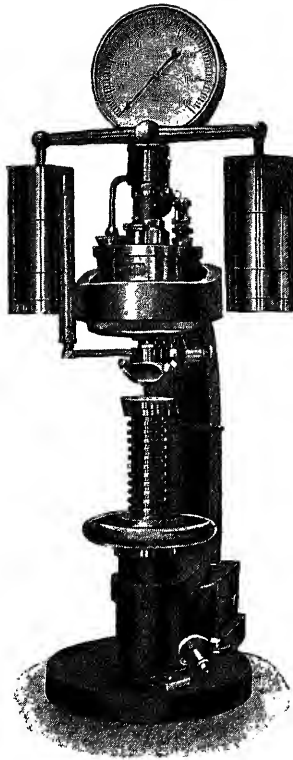

FIG. 110.—SWEDISH BRINELL MACHINE.



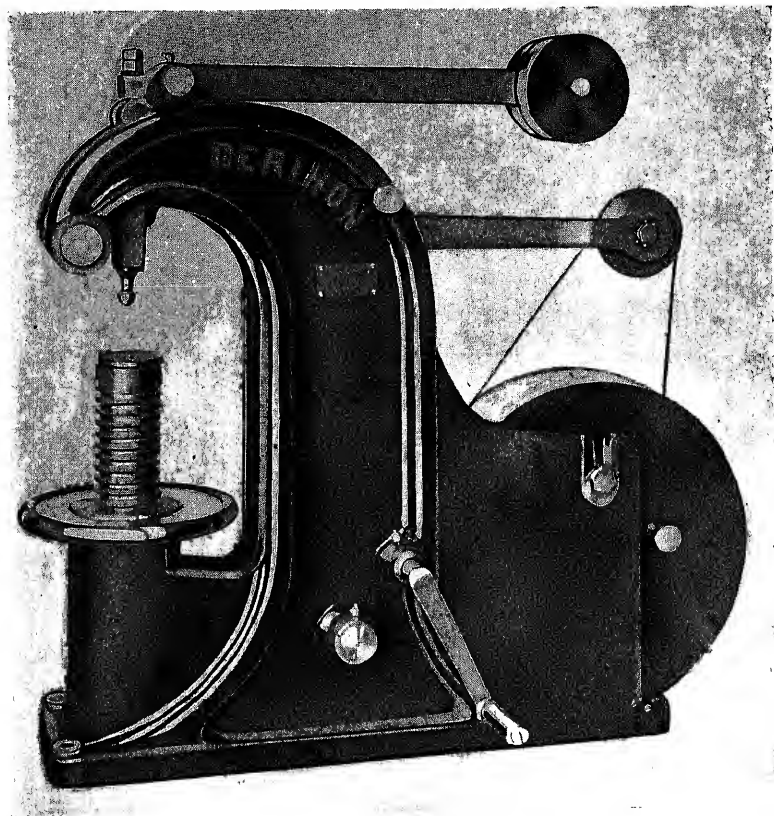

FIG. 112.—WORKS MODEL OF DERIHON "HARDNESS TESTING" MACHINE.

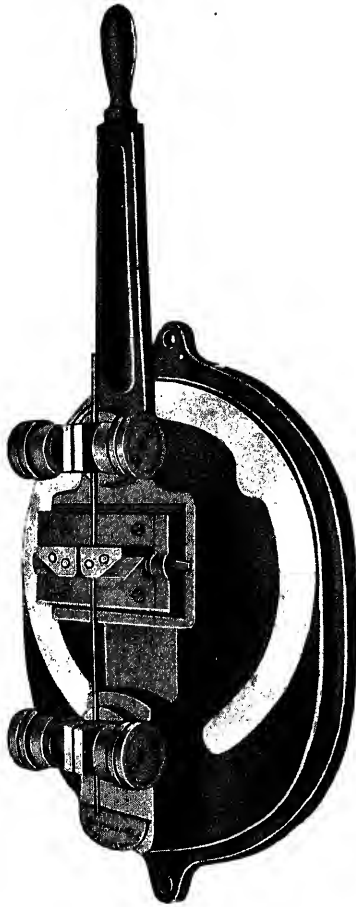

FIG. 115.—LEE REVERSE BEND TESTING MACHINE SHOWING INITIAL POSITION OF SPECIMEN

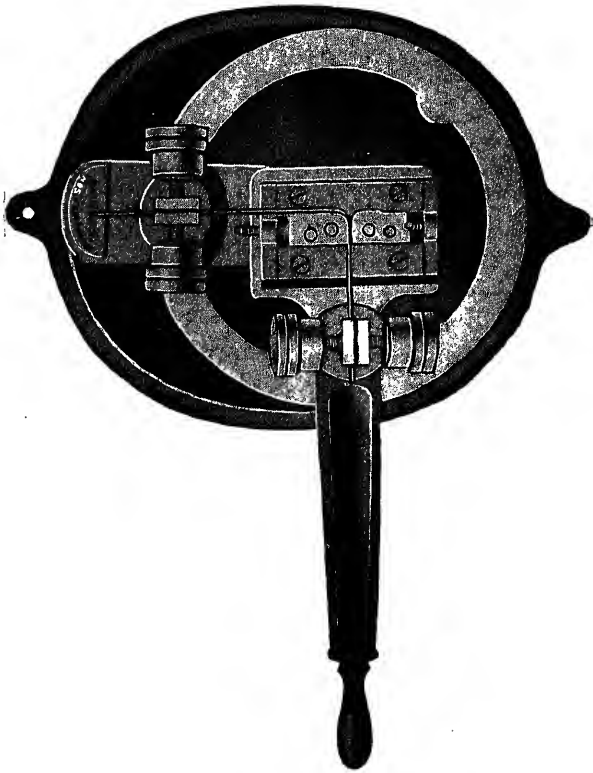
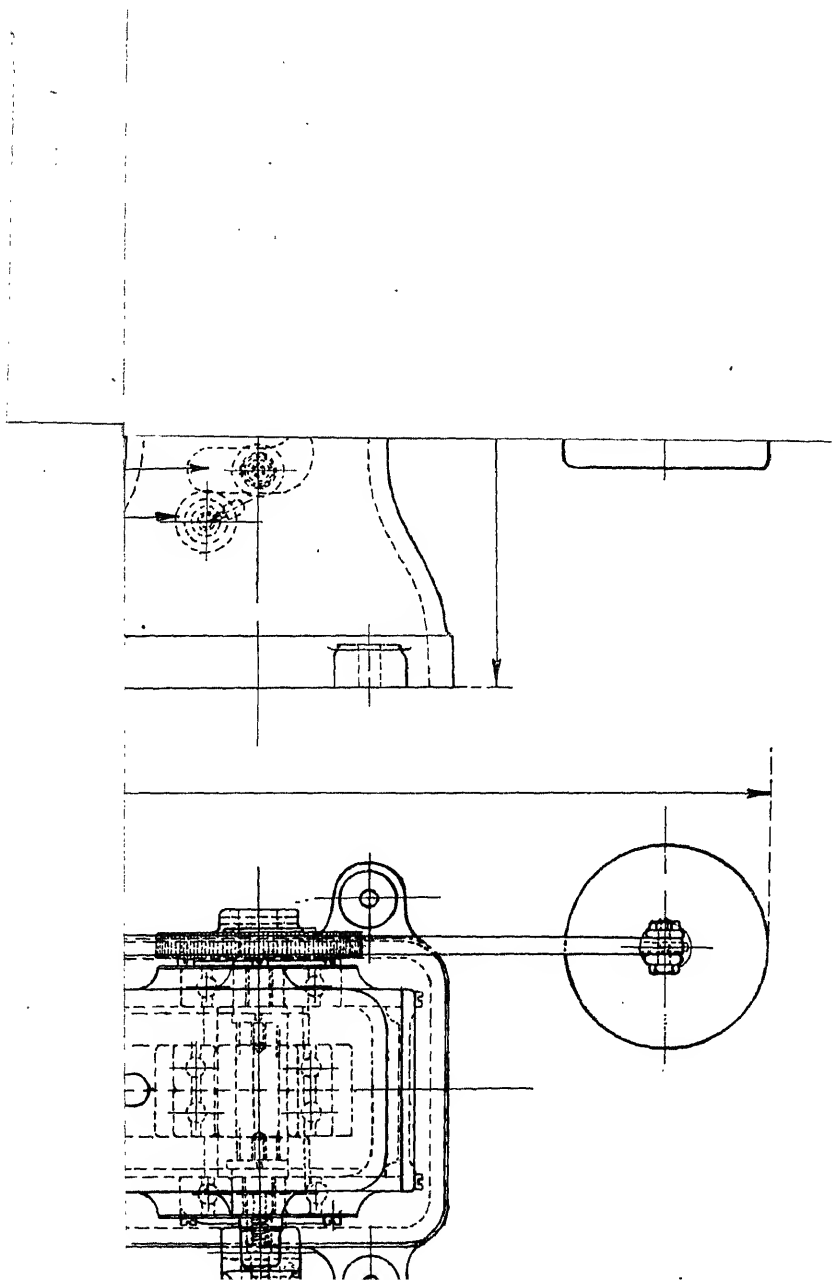

FIG. 116.—LEE REVERSE BEND TESTING MACHINE  
SHOWING POSITION OF SPECIMEN AFTER BENDING  
THROUGH 90°.



# THE RECONSTRUCTIVE TECHNICAL SERIES

---

A new series of technical works, planned and edited by the well-known physicist and technician, Mr. G. W. de Tunzelman, is now in course of publication, under the general title of the *Reconstructive Technical Series*.

In the *Reconstructive Technical Series* the Editor's aim is to diffuse the new knowledge and enlarged technical skill gained during recent years—to a great extent under stress of the war—and so make it available for the practitioner of to-day, as a means towards greater all-round efficiency and increased competitive power in the world's markets.

The volumes of the *Reconstructive Technical Series* will be occupied with theory also so far as an understanding of theory is necessary to practical mastery of the subject and the processes dealt with. But, though primarily intended for the practitioner, each volume will appeal powerfully to the student, as providing that element of actuality which the purely scientific investigator, working, so to speak, *in vacuo*, not infrequently lacks.

Each volume is designed to serve a particular industry or vocation, and the methods of treatment adopted by Dr. Aitchison in *Engineering Steels* may be taken to be normative of the new series as a whole.

It should be unnecessary to add that the writers engaged for the Series are only such writers as the shrewdest and most informative judgment would be likely to select.

Other volumes will follow in quick succession.

PRINTED IN GREAT BRITAIN  
BY UNWIN BROTHERS, LIMITED  
PRINTERS, WOKING AND LONDON

# D. VAN NOSTRAND COMPANY

---

are prepared to supply, either from  
their complete stock or at  
short notice,

## Any Technical or Scientific Book

In addition to publishing a very large and varied number of SCIENTIFIC AND ENGINEERING BOOKS, D. Van Nostrand Company have on hand the largest assortment in the United States of such books issued by American and foreign publishers.

---

All inquiries are cheerfully and carefully answered and complete catalogs sent free on request.

---

8 WARREN STREET - - - NEW YORK